

ANALYSIS, SYNTHESIS, AND DESIGN OF CHEMICAL PROCESSES

FIFTH EDITION

RICHARD TURTON | JOSEPH A. SHAEIWITZ
DEBANGSU BHATTACHARYYA | WALLACE B. WHITING



PRENTICE HALL INTERNATIONAL SERIES IN THE
PHYSICAL AND CHEMICAL ENGINEERING SCIENCES



FREE SAMPLE CHAPTER

SHARE WITH OTHERS



**Analysis, Synthesis,
and Design
of Chemical Processes**

Fifth Edition

This page intentionally left blank

Analysis, Synthesis, and Design of Chemical Processes

Fifth Edition

Richard Turton

Joseph A. Shaeiwitz

Debangsu Bhattacharyya

Wallace B. Whiting



PRENTICE
HALL

Boston • Columbus • Indianapolis • New York • San Francisco • Amsterdam • Cape Town
Dubai • London • Madrid • Milan • Munich • Paris • Montreal • Toronto • Delhi • Mexico City
São Paulo • Sydney • Hong Kong • Seoul • Singapore • Taipei • Tokyo

Many of the designations used by manufacturers and sellers to distinguish their products are claimed as trademarks. Where those designations appear in this book, and the publisher was aware of a trademark claim, the designations have been printed with initial capital letters or in all capitals.

The authors and publisher have taken care in the preparation of this book, but make no expressed or implied warranty of any kind and assume no responsibility for errors or omissions. No liability is assumed for incidental or consequential damages in connection with or arising out of the use of the information or programs contained herein.

For information about buying this title in bulk quantities, or for special sales opportunities (which may include electronic versions; custom cover designs; and content particular to your business, training goals, marketing focus, or branding interests), please contact our corporate sales department at corpsales@pearsoned.com or (800) 382-3419.

For government sales inquiries, please contact governmentsales@pearsoned.com.

For questions about sales outside the U.S., please contact intlcs@pearson.com.

Visit us on the Web: informit.com

Library of Congress Control Number: 2018930278

Copyright © 2018 Pearson Education, Inc.

All rights reserved. This publication is protected by copyright, and permission must be obtained from the publisher prior to any prohibited reproduction, storage in a retrieval system, or transmission in any form or by any means, electronic, mechanical, photocopying, recording, or likewise. For information regarding permissions, request forms and the appropriate contacts within the Pearson Education Global Rights & Permissions Department, please visit www.pearsoned.com/permissions/.

ISBN-13: 978-0-13-417740-3

ISBN-10: 0-13-417740-1

To the memory of Richard (Dick) C. Bailie (1928–2014)
Colleague, Friend, and Mentor

This page intentionally left blank

Contents

Preface xxv

About the Authors xxix

List of Nomenclature xxxi

Chapter 0 Outcomes Assessment 1

0.1 Student Self-Assessment 2

0.2 Assessment by Faculty 4

0.3 Summary 6

References 6

SECTION I Conceptualization and Analysis of Chemical Processes 7

Chapter 1 Diagrams for Understanding Chemical Processes 9

1.1 Block Flow Diagram (BFD) 11

1.1.1 Block Flow Process Diagram 11

1.1.2 Block Flow Plant Diagram 12

1.2 Process Flow Diagram (PFD) 14

1.2.1 Process Topology 14

1.2.2 Stream Information 18

1.2.3 Equipment Information 21

1.2.4 Combining Topology, Stream Data, and Control Strategy to Give a PFD 21

1.3 Piping and Instrumentation Diagram (P&ID) 27

1.4 Additional Diagrams 32

1.5 Three-Dimensional Representation of a Process 34

1.6 The 3-D Plant Model 41

1.7 Operator and 3-D Immersive Training Simulators 43

1.7.1 Operator Training Simulators (OTS) 43

1.7.2 3-D Immersive Training Simulators (ITS) 45

1.7.3 Linking the ITS with an OTS 46

1.8 Summary 48

References 49

Short Answer Questions 49

Problems 50

Chapter 2 The Structure and Synthesis of Process Flow Diagrams 55

2.1 Hierarchy of Process Design 55

2.2 Step 1—Batch versus Continuous Process 56

- 2.3 Step 2—The Input/Output Structure of the Process 60
 - 2.3.1 *Process Concept Diagram* 60
 - 2.3.2 *The Input/Output Structure of the Process Flow Diagram* 61
 - 2.3.3 *The Input/Output Structure and Other Features of the Generic Block Flow Process Diagram* 63
 - 2.3.4 *Other Considerations for the Input/Output Structure of the Process Flowsheet* 65
 - 2.3.5 *What Information Can Be Determined Using the Input/Output Diagram for a Process?* 68
- 2.4 Step 3—The Recycle Structure of the Process 70
 - 2.4.1 *Efficiency of Raw Material Usage* 70
 - 2.4.2 *Identification and Definition of the Recycle Structure of the Process* 71
 - 2.4.3 *Other Issues Affecting the Recycle Structure That Lead to Process Alternatives* 75
- 2.5 Step 4—General Structure of the Separation System 83
- 2.6 Step 5—Heat-Exchanger Network or Process Energy Recovery System 83
- 2.7 Information Required and Sources 83
- 2.8 Summary 83
 - References 85
 - Short Answer Questions 86
 - Problems 86

Chapter 3 Batch Processing 91

- 3.1 Design Calculations for Batch Processes 91
- 3.2 Gantt Charts and Scheduling 97
- 3.3 Nonoverlapping Operations, Overlapping Operations, and Cycle Times 98
- 3.4 Flowshop and Jobshop Plants 101
 - 3.4.1 *Flowshop Plants* 101
 - 3.4.2 *Jobshop Plants* 103
- 3.5 Product and Intermediate Storage and Parallel Process Units 106
 - 3.5.1 *Product Storage for Single-Product Campaigns* 106
 - 3.5.2 *Intermediate Storage* 108
 - 3.5.3 *Parallel Process Units* 110
- 3.6 Design of Equipment for Multiproduct Batch Processes 111
- 3.7 Summary 113
 - References 114
 - Short Answer Questions 114
 - Problems 114

Chapter 4 Chemical Product Design 123

- 4.1 Strategies for Chemical Product Design 124
- 4.2 Needs 125
- 4.3 Ideas 127
- 4.4 Selection 128
- 4.5 Manufacture 130
- 4.6 Batch Processing 131
- 4.7 Economic Considerations 131
- 4.8 Summary 132
 - References 132

Chapter 5	Tracing Chemicals through the Process Flow Diagram	135
5.1	Guidelines and Tactics for Tracing Chemicals	135
5.2	Tracing Primary Paths Taken by Chemicals in a Chemical Process	136
5.3	Recycle and Bypass Streams	142
5.4	Tracing Nonreacting Chemicals	145
5.5	Limitations	145
5.6	Written Process Description	146
5.7	Summary	147
	Problems	147
Chapter 6	Understanding Process Conditions	149
6.1	Conditions of Special Concern for the Operation of Separation and Reactor Systems	150
6.1.1	Pressure	150
6.1.2	Temperature	150
6.2	Reasons for Operating at Conditions of Special Concern	152
6.3	Conditions of Special Concern for the Operation of Other Equipment	155
6.4	Analysis of Important Process Conditions	158
6.4.1	Evaluation of Reactor R-101	158
6.4.2	Evaluation of High-Pressure Phase Separator V-102	164
6.4.3	Evaluation of Large Temperature Driving Force in Exchanger E-101	164
6.4.4	Evaluation of Exchanger E-102	164
6.4.5	Pressure Control Valve on Stream 8	164
6.4.6	Pressure Control Valve on Stream from V-102 to V-103	164
6.5	Summary	165
	References	165
	Short Answer Questions	165
	Problems	166
SECTION II	Engineering Economic Analysis of Chemical Processes	169
Chapter 7	Estimation of Capital Costs	171
7.1	Classifications of Capital Cost Estimates	172
7.2	Estimation of Purchased Equipment Costs	175
7.2.1	Effect of Capacity on Purchased Equipment Cost	175
7.2.2	Effect of Time on Purchased Equipment Cost	179
7.3	Estimating the Total Capital Cost of a Plant	182
7.3.1	Lang Factor Technique	184
7.3.2	Module Costing Technique	185
7.3.3	Bare Module Cost for Equipment at Base Conditions	186
7.3.4	Bare Module Cost for Non-Base-Case Conditions	189
7.3.5	Combination of Pressure and MOC Information to Give the Bare Module Factor, F_{BM} , and Bare Module Cost, C_{BM}	199
7.3.6	Algorithm for Calculating Bare Module Costs	200
7.3.7	Grassroots (Green Field) and Total Module Costs	201
7.3.8	A Computer Program (CAPCOST) for Capital Cost Estimation Using the Equipment Module Approach	204
7.4	Estimation of Plant Costs Based on Capacity Information	206

7.5	Summary	208
	References	208
	Short Answer Questions	209
	Problems	210
Chapter 8	Estimation of Manufacturing Costs	213
8.1	Factors Affecting the Cost of Manufacturing a Chemical Product	213
8.2	Cost of Operating Labor	218
8.3	Utility Costs	219
	8.3.1 Background Information on Utilities	219
	8.3.2 Calculation of Utility Costs	221
8.4	Raw Material Costs	234
8.5	Yearly Costs and Stream Factors	237
8.6	Estimating Utility Costs from the PFD	238
8.7	Cost of Treating Liquid and Solid Waste Streams	240
8.8	Evaluation of Cost of Manufacture for the Production of Benzene via the Hydrodealkylation of Toluene	241
8.9	Summary	242
	References	243
	Short Answer Questions	243
	Problems	244
Chapter 9	Engineering Economic Analysis	247
9.1	Investments and the Time Value of Money	248
9.2	Different Types of Interest	251
	9.2.1 Simple Interest	252
	9.2.2 Compound Interest	252
	9.2.3 Interest Rates Changing with Time	253
9.3	Time Basis for Compound Interest Calculations	254
	9.3.1 Effective Annual Interest Rate	254
	9.3.2 Continuously Compounded Interest	255
9.4	Cash Flow Diagrams	255
	9.4.1 Discrete Cash Flow Diagram	256
	9.4.2 Cumulative Cash Flow Diagram	258
9.5	Calculations from Cash Flow Diagrams	259
	9.5.1 Annuities—A Uniform Series of Cash Transactions	260
	9.5.2 Discount Factors	261
9.6	Inflation	266
9.7	Depreciation of Capital Investment	268
	9.7.1 Fixed Capital, Working Capital, and Land	269
	9.7.2 Different Types of Depreciation	269
	9.7.3 Current Depreciation Method (2017): Modified Accelerated Cost Recovery System (MACRS)	273
9.8	Taxation, Cash Flow, and Profit	274
9.9	Summary	277
	References	277
	Short Answer Questions	278
	Problems	278

Chapter 10	Profitability Analysis	285
10.1	A Typical Cash Flow Diagram for a New Project	285
10.2	Profitability Criteria for Project Evaluation	287
10.2.1	<i>Nondiscounted Profitability Criteria</i>	287
10.2.2	<i>Discounted Profitability Criteria</i>	291
10.3	Comparing Several Large Projects: Incremental Economic Analysis	295
10.4	Establishing Acceptable Returns from Investments: The Concept of Risk	298
10.5	Evaluation of Equipment Alternatives	299
10.5.1	<i>Equipment with the Same Expected Operating Lives</i>	299
10.5.2	<i>Equipment with Different Expected Operating Lives</i>	300
10.6	Incremental Analysis for Retrofitting Facilities	305
10.6.1	<i>Nondiscounted Methods for Incremental Analysis</i>	305
10.6.2	<i>Discounted Methods for Incremental Analysis</i>	308
10.7	Evaluation of Risk in Evaluating Profitability	309
10.7.1	<i>Forecasting Uncertainty in Chemical Processes</i>	310
10.7.2	<i>Quantifying Risk</i>	314
10.8	Profit Margin Analysis	325
10.9	Summary	326
	References	327
	Short Answer Questions	327
	Problems	328
SECTION III Synthesis and Optimization of Chemical Processes		343
Chapter 11	Utilizing Experience-Based Principles to Confirm the Suitability of a Process Design	347
11.1	The Role of Experience in the Design Process	348
11.1.1	<i>Introduction to Technical Heuristics and Shortcut Methods</i>	348
11.1.2	<i>Maximizing the Benefits Obtained from Experience</i>	349
11.2	Presentation of Tables of Technical Heuristics and Guidelines	351
11.3	Summary	354
	List of Informational Tables	354
	References	368
	Problems	368
Chapter 12	Synthesis of the PFD from the Generic BFD	369
12.1	Information Needs and Sources	370
12.1.1	<i>Interactions with Other Engineers and Scientists</i>	370
12.1.2	<i>Reaction Kinetics Data</i>	370
12.1.3	<i>Physical Property Data</i>	371
12.2	Reactor Section	372
12.3	Separator Section	373
12.3.1	<i>General Guidelines for Choosing Separation Operations</i>	374
12.3.2	<i>Sequencing of Distillation Columns for Simple Distillation</i>	376
12.3.3	<i>Azeotropic Distillation</i>	378

12.4	Reactor Feed Preparation and Separator Feed Preparation Sections	388
12.5	Recycle Section	389
12.6	Environmental Control Section	389
12.7	Major Process Control Loops	390
12.8	Flow Summary Table	390
12.9	Major Equipment Summary Table	390
12.10	Summary	391
	References	391
	General Reference	392
	Problems	392

Chapter 13 Synthesis of a Process Using a Simulator and Simulator Troubleshooting 397

13.1	The Structure of a Process Simulator	398
13.2	Information Required to Complete a Process Simulation: Input Data	401
	13.2.1 Selection of Chemical Components	401
	13.2.2 Selection of Physical Property Models	401
	13.2.3 Selection and Input of Flowsheet Topology	404
	13.2.4 Selection of Feed Stream Properties	404
	13.2.5 Selection of Equipment Parameters	405
	13.2.6 Selection of Output Display Options	411
	13.2.7 Selection of Convergence Criteria and Running a Simulation	411
	13.2.8 Common Errors in Using Simulators	412
13.3	Handling Recycle Streams	413
13.4	Choosing Thermodynamic Models	415
	13.4.1 Pure-Component Properties	416
	13.4.2 Enthalpy	416
	13.4.3 Phase Equilibria	416
	13.4.4 Using Thermodynamic Models	424
13.5	Case Study: Toluene Hydrodealkylation Process	426
13.6	Electrolyte Systems Modeling	428
	13.6.1 Fundamentals of Modeling Electrolyte Systems	429
	13.6.2 Steps Needed to Build the Model of an Aqueous Electrolyte System and the Estimation of Parameters	435
13.7	Solids Modeling	440
	13.7.1 Physical Properties	440
	13.7.2 Parameter Requirements for Solids Model	442
Appendix 13.1	445	
	Calculation of Excess Gibbs Energy for Electrolyte Systems	445
Appendix 13.2	447	
	Steps to Build a Model of a Distillation Column for an Electrolyte System Using a Rate-Based Simulation with a Film Model for Mass Transfer, the Parameters Required at Each Stage, and Possible Sources of These Parameters	447
13.8	Summary	450
	References	451
	Short Answer Questions	454
	Problems	455

Chapter 14	Process Optimization	463
14.1	Background Information on Optimization	463
14.1.1	Common Misconceptions	465
14.1.2	Estimating Problem Difficulty	467
14.1.3	Top-Down and Bottom-Up Strategies	468
14.1.4	Communication of Optimization Results	468
14.2	Strategies	469
14.2.1	Base Case	469
14.2.2	Objective Functions	470
14.2.3	Analysis of the Base Costs	471
14.2.4	Identifying and Prioritizing Key Decision Variables	471
14.3	Topological Optimization	473
14.3.1	Introduction	473
14.3.2	Elimination of Unwanted Nonhazardous By-Products or Hazardous Waste Streams	473
14.3.3	Elimination and Rearrangement of Equipment	475
14.3.4	Alternative Separation Schemes and Reactor Configurations	477
14.4	Parametric Optimization	479
14.4.1	Single-Variable Optimization: A Case Study on T-201, the DME Separation Column	480
14.4.2	Two-Variable Optimization: The Effect of Pressure and Reflux Ratio on T-201, the DME Separation Column	481
14.4.3	Flowsheet Optimization Using Key Decision Variables	484
14.5	Lattice Search, Response Surface, and Mathematical Optimization Techniques	489
14.6	Process Flexibility and the Sensitivity of the Optimum	489
14.7	Optimization in Batch Systems	490
14.7.1	Problem of Scheduling Equipment	490
14.7.2	Problem of Optimum Cycle Time	495
14.8	Summary	497
	References	498
	Short Answer Questions	498
	Problems	498
Chapter 15	Pinch Technology	509
15.1	Introduction	509
15.2	Heat Integration and Network Design	510
15.3	Composite Temperature-Enthalpy Diagram	523
15.4	Composite Enthalpy Curves for Systems without a Pinch	524
15.5	Using the Composite Enthalpy Curve to Estimate Heat-Exchanger Surface Area	525
15.6	Effectiveness Factor (F) and the Number of Shells	529
15.7	Combining Costs to Give the EAO for the Network	534
15.8	Other Considerations	536
15.8.1	Materials of Construction and Operating Pressure Issues	536
15.8.2	Problems with Multiple Utilities	539
15.8.3	Handling Streams with Phase Changes	539

15.9	Heat-Exchanger Network Synthesis Analysis and Design (HENSAD) Program	540
15.10	Mass-Exchange Networks	541
15.11	Summary	550
	References	550
	Short Answer Questions	551
	Problems	552
Chapter 16	Advanced Topics Using Steady-State Simulators	561
16.1	Why the Need for Advanced Topics in Steady-State Simulation?	562
16.2	User-Added Models	562
	16.2.1 Unit Operation Models	563
	16.2.2 User Thermodynamic and Transport Models	564
	16.2.3 User Kinetic Models	568
16.3	Solution Strategy for Steady-State Simulations	571
	16.3.1 Sequential Modular (SM)	572
	16.3.2 Equation-Oriented (EO)	585
	16.3.3 Simultaneous Modular (SMod)	586
16.4	Studies with the Steady-State Simulation	589
	16.4.1 Sensitivity Studies	589
	16.4.2 Optimization Studies	589
16.5	Estimation of Physical Property Parameters	601
16.6	Summary	605
	References	605
	Short Answer Questions	607
	Problems	607
Chapter 17	Using Dynamic Simulators in Process Design	617
17.1	Why Is There a Need for Dynamic Simulation?	618
17.2	Setting Up a Dynamic Simulation	619
	17.2.1 Step 1: Topological Change in the Steady-State Simulation	619
	17.2.2 Step 2: Equipment Geometry and Size	622
	17.2.3 Step 3: Additional Dynamic Data/Dynamic Specification	624
17.3	Dynamic Simulation Solution Methods	633
	17.3.1 Initialization	634
	17.3.2 Solution of the DAE System	634
17.4	Process Control	639
17.5	Summary	647
	References	647
	Short Answer Questions	648
	Problems	649
Chapter 18	Regulation and Control of Chemical Processes with Applications Using Commercial Software	655
18.1	A Simple Regulation Problem	656
18.2	The Characteristics of Regulating Valves	657
18.3	Regulating Flowrates and Pressures	660
18.4	The Measurement of Process Variables	662

- 18.5 Common Control Strategies Used in Chemical Processes 663
 - 18.5.1 *Feedback Control and Regulation* 663
 - 18.5.2 *Feed-Forward Control and Regulation* 665
 - 18.5.3 *Combination Feedback and Feed-Forward Control* 667
 - 18.5.4 *Cascade Regulation* 668
 - 18.5.5 *Ratio Control* 669
 - 18.5.6 *Split-Range Control* 671
- 18.6 Exchanging Heat and Work between Process and Utility Streams 674
 - 18.6.1 *Increasing the Pressure of a Process Stream and Regulating Its Flowrate* 674
 - 18.6.2 *Exchanging Heat between Process Streams and Utilities* 676
 - 18.6.3 *Exchanging Heat between Process Streams* 679
- 18.7 Logic Control 680
- 18.8 Advanced Process Control 682
 - 18.8.1 *Statistical Process Control (SPC)* 682
 - 18.8.2 *Model-Based Control* 683
- 18.9 Case Studies 683
 - 18.9.1 *The Cumene Reactor, R-801* 683
 - 18.9.2 *A Basic Control System for a Binary Distillation Column* 685
 - 18.9.3 *A More Sophisticated Control System for a Binary Distillation Column* 687
- 18.10 Putting It All Together: The Operator Training Simulator (OTS) 688
- 18.11 Summary 689
 - References 690
 - Problems 690

SECTION IV Chemical Equipment Design and Performance Process Equipment Design and Performance 695

Chapter 19 Process Fluid Mechanics 697

- 19.1 Basic Relationships in Fluid Mechanics 697
 - 19.1.1 *Mass Balance* 698
 - 19.1.2 *Mechanical Energy Balance* 700
 - 19.1.3 *Force Balance* 703
- 19.2 Fluid Flow Equipment 703
 - 19.2.1 *Pipes* 703
 - 19.2.2 *Valves* 705
 - 19.2.3 *Pumps* 706
 - 19.2.4 *Compressors* 707
- 19.3 Frictional Pipe Flow 709
 - 19.3.1 *Calculating Frictional Losses* 709
 - 19.3.2 *Incompressible Flow* 712
 - 19.3.3 *Compressible Flow* 719
 - 19.3.4 *Choked Flow* 720
- 19.4 Other Flow Situations 723
 - 19.4.1 *Flow Past Submerged Objects* 723
 - 19.4.2 *Fluidized Beds* 728
 - 19.4.3 *Flowrate Measurement* 730

19.5	Performance of Fluid Flow Equipment	736
19.5.1	Base-Case Ratios	736
19.5.2	Net Positive Suction Head	739
19.5.3	Pump and System Curves	743
19.5.4	Compressors	749
19.5.5	Performance of the Feed Section to a Process	752
	References	755
	Short Answer Questions	756
	Problems	757
Chapter 20	Process Heat Transfer	771
20.1	Basic Heat-Exchanger Relationships	771
20.1.1	Countercurrent Flow	771
20.1.2	Cocurrent Flow	773
20.1.3	Streams with Phase Changes	775
20.1.4	Nonlinear Q versus T Curves	776
20.1.5	Overall Heat Transfer Coefficient, U, Varies along the Exchanger	777
20.2	Heat-Exchange Equipment Design and Characteristics	779
20.2.1	Shell-and-Tube Heat Exchangers	779
20.3	LMTD Correction Factor for Multiple Shell and Tube Passes	789
20.3.1	Background	789
20.3.2	Basic Configuration of a Single-Shell-Pass, Double-Tube-Pass (1–2) Exchanger	790
20.3.3	Multiple Shell-and-Tube-Pass Exchangers	793
20.3.4	Cross-Flow Exchangers	797
20.3.5	LMTD Correction and Phase Change	797
20.4	Overall Heat Transfer Coefficients—Resistances in Series	798
20.5	Estimation of Individual Heat Transfer Coefficients and Fouling Resistances	800
20.5.1	Heat Transfer Resistances Due to Fouling	800
20.5.2	Thermal Conductivities of Common Metals and Tube Properties	800
20.5.3	Correlations for Film Heat Transfer Coefficients	803
20.6	Extended Surfaces	828
20.6.1	Rectangular Fin with Constant Thickness	829
20.6.2	Fin Efficiency for Other Fin Geometries	830
20.6.3	Total Heat Transfer Surface Effectiveness	831
20.7	Algorithm and Worked Examples for the Design of Heat Exchangers	837
20.7.1	Pressure Drop Considerations	837
20.7.2	Design Algorithm	838
20.8	Performance Problems	846
20.8.1	What Variables to Specify in Performance Problems	847
20.8.2	Using Ratios to Determine Heat-Exchanger Performance	847
20.8.3	Worked Examples for Performance Problems	850
	References	859
Appendix 20.A	Heat-Exchanger Effectiveness Charts	861
Appendix 20.B	Derivation of Fin Effectiveness for a Rectangular Fin	864
	Short Answer Questions	866
	Problems	866

Chapter 21	Separation Equipment	875
21.1	Basic Relationships in Separations	876
21.1.1	Mass Balances	876
21.1.2	Energy Balances	877
21.1.3	Equilibrium Relationships	877
21.1.4	Mass Transfer Relationships	878
21.1.5	Rate Expressions	882
21.2	Illustrative Diagrams	883
21.2.1	TP-xy Diagrams	883
21.2.2	McCabe-Thiele Diagram	888
21.2.3	Dilute Solutions—The Kremser and Colburn Methods	905
21.3	Equipment	911
21.3.1	Drums	911
21.3.2	Tray Towers	912
21.3.3	Packed Towers	926
21.3.4	Tray Tower or Packed Tower?	933
21.3.5	Performance of Packed and Tray Towers	933
	Case Study	934
21.4	Extraction Equipment	942
21.4.1	Mixer-Settlers	943
21.4.2	Static and Pulsed Columns	943
21.4.3	Agitated Columns	943
21.4.4	Centrifugal Extractors	943
21.5	Gas Permeation Membrane Separations	947
21.5.1	Equipment	947
21.5.2	Models for Gas Permeation Membranes	949
21.5.3	Practical Issues	950
	References	951
	Short Answer Questions	952
	Problems	954
Chapter 22	Reactors	961
22.1	Basic Relationships	962
22.1.1	Kinetics	962
22.1.2	Equilibrium	964
22.1.3	Additional Mass Transfer Effects	965
22.1.4	Mass Balances	970
22.1.5	Energy Balances	971
22.1.6	Reactor Models	972
22.2	Equipment Design for Nonisothermal Conditions	980
22.2.1	Nonisothermal Continuous Stirred Tank Reactor	980
22.2.2	Nonisothermal Plug Flow Reactor	984
22.2.3	Fluidized Bed Reactor	999
22.3	Performance Problems	1003
22.3.1	Ratios for Simple Cases	1003
22.3.2	More Complex Examples	1004
	References	1007
	Short Answer Questions	1007
	Problems	1008

Chapter 23 Other Equipment 1015

- 23.1 Pressure Vessels 1016
 - 23.1.1 *Material Properties* 1016
 - 23.1.2 *Basic Design Equations* 1016
- 23.2 Knockout Drums or Simple Phase Separators 1024
 - 23.2.1 *Vapor-Liquid (V-L) Separation* 1025
 - 23.2.2 *Design of Vertical V-L Separators* 1029
 - 23.2.3 *Design of Horizontal V-L Separators* 1032
 - 23.2.4 *Mist Eliminators and Other Internals* 1036
 - 23.2.5 *Liquid-Liquid (L-L) Separation* 1044
- 23.3 Steam Ejectors 1049
 - 23.3.1 *Estimating Air Leaks into Vacuum Systems and the Load for Steam Ejectors* 1050
 - 23.3.2 *Single-Stage Steam Ejectors* 1051
 - 23.3.3 *Multistage Steam Ejectors* 1054
 - 23.3.4 *Performance of Steam Ejectors* 1057
 - References 1058
 - Short Answer Questions 1059
 - Problems 1060

Chapter 24 Process Troubleshooting and Debottlenecking 1065

- 24.1 Recommended Methodology 1067
 - 24.1.1 *Elements of Problem-Solving Strategies* 1067
 - 24.1.2 *Application to Troubleshooting Problems* 1069
- 24.2 Troubleshooting Individual Units 1071
 - 24.2.1 *Troubleshooting a Packed-Bed Absorber* 1071
 - 24.2.2 *Troubleshooting the Cumene Process Feed Section* 1074
- 24.3 Troubleshooting Multiple Units 1076
 - 24.3.1 *Troubleshooting Off-Specification Acrylic Acid Product* 1076
 - 24.3.2 *Troubleshooting Steam Release in Cumene Reactor* 1078
- 24.4 A Process Troubleshooting Problem 1081
- 24.5 Debottlenecking Problems 1085
- 24.6 Summary 1091
 - References 1091
 - Problems 1091

SECTION V The Impact of Chemical Engineering Design on Society 1101**Chapter 25 Ethics and Professionalism 1103**

- 25.1 Ethics 1104
 - 25.1.1 *Moral Autonomy* 1105
 - 25.1.2 *Rehearsal* 1105
 - 25.1.3 *Reflection in Action* 1106
 - 25.1.4 *Mobile Truth* 1107
 - 25.1.5 *Nonprofessional Responsibilities* 1108
 - 25.1.6 *Duties and Obligations* 1110
 - 25.1.7 *Codes of Ethics* 1110

- 25.1.8 Whistle-Blowing [12] 1115
- 25.1.9 Ethical Dilemmas 1117
- 25.1.10 Additional Ethics Heuristics 1118
- 25.1.11 Other Resources 1118
- 25.2 Professional Registration 1121
 - 25.2.1 Engineer-in-Training 1122
 - 25.2.2 Registered Professional Engineer 1124
- 25.3 Legal Liability [13] 1125
- 25.4 Business Codes of Conduct [14, 15] 1126
- 25.5 Summary 1127
 - References 1128
 - Problems 1129

Chapter 26 Health, Safety, and the Environment 1131

- 26.1 Risk Assessment 1131
 - 26.1.1 Accident Statistics 1132
 - 26.1.2 Worst-Case Scenarios 1133
 - 26.1.3 The Role of the Chemical Engineer 1134
- 26.2 Regulations and Agencies 1134
 - 26.2.1 OSHA and NIOSH 1135
 - 26.2.2 Environmental Protection Agency (EPA) 1140
 - 26.2.3 Nongovernmental Organizations 1143
- 26.3 Fires and Explosions 1143
 - 26.3.1 Terminology 1143
 - 26.3.2 Pressure-Relief Systems 1145
- 26.4 Process Hazard Analysis 1145
 - 26.4.1 HAZOP (Hazard and Operability Study) 1146
 - 26.4.2 Dow Fire & Explosion Index and Chemical Exposure Index 1147
- 26.5 Chemical Safety and Hazard Investigation Board 1153
- 26.6 Inherently Safe Design 1153
- 26.7 Summary 1154
- 26.8 Glossary 1154
 - References 1156
 - Problems 1157

Chapter 27 Green Engineering 1159

- 27.1 Environmental Regulations 1159
- 27.2 Environmental Fate of Chemicals 1160
- 27.3 Green Chemistry 1163
- 27.4 Pollution Prevention during Process Design 1164
- 27.5 Analysis of a PFD for Pollution Performance and Environmental Performance 1166
- 27.6 An Example of the Economics of Pollution Prevention 1167
- 27.7 Life Cycle Analysis 1168
- 27.8 Summary 1169
 - References 1170
 - Problems 1171

SECTION VI Interpersonal and Communication Skills 1173

Chapter 28 Teamwork 1175

- 28.1 Groups 1175
 - 28.1.1 *Characteristics of Effective Groups* 1176
 - 28.1.2 *Assessing and Improving the Effectiveness of a Group* 1178
 - 28.1.3 *Organizational Behaviors and Strategies* 1180
- 28.2 Group Evolution 1184
 - 28.2.1 *Forming* 1184
 - 28.2.2 *Storming* 1184
 - 28.2.3 *Norming* 1185
 - 28.2.4 *Performing* 1186
- 28.3 Teams and Teamwork 1186
 - 28.3.1 *When Groups Become Teams* 1186
 - 28.3.2 *Unique Characteristics of Teams* 1187
- 28.4 Misconceptions 1189
 - 28.4.1 *Team Exams* 1189
 - 28.4.2 *Overreliance on Team Members* 1189
- 28.5 Learning in Teams 1189
- 28.6 Other Reading 1190
- 28.7 Summary 1191
 - References 1192
 - Problems 1192

Chapter 29 Written and Oral Communication 1195

- 29.1 Audience Analysis 1196
- 29.2 Written Communication 1196
 - 29.2.1 *Design Reports* 1197
 - 29.2.2 *Transmittal Letters or Memos* 1198
 - 29.2.3 *Executive Summaries and Abstracts* 1198
 - 29.2.4 *Other Types of Written Communication* 1199
 - 29.2.5 *Exhibits (Figures and Tables)* 1200
 - 29.2.6 *References* 1200
 - 29.2.7 *Strategies for Writing* 1201
 - 29.2.8 *WVU and Auburn University Guidelines for Written Design Reports* 1202
- 29.3 Oral Communication 1209
 - 29.3.1 *Formal Oral Presentations* 1210
 - 29.3.2 *Briefings* 1211
 - 29.3.3 *Visual Aids* 1211
 - 29.3.4 *WVU and Auburn University Oral Presentation Guidelines* 1212
- 29.4 Software and Author Responsibility 1215
 - 29.4.1 *Spell Checkers* 1215
 - 29.4.2 *Thesaurus* 1215
 - 29.4.3 *Grammar Checkers* 1215
 - 29.4.4 *Graphs* 1216
 - 29.4.5 *Tables* 1217
 - 29.4.6 *Colors and Exotic Features* 1217
 - 29.4.7 *Raw Output from Process Simulators* 1217

29.5	Summary	1218
	References	1218
	Problems	1219
Chapter 30	A Report-Writing Case Study	1221
30.1	The Assignment Memorandum	1221
30.2	Response Memorandum	1222
30.3	Visual Aids	1224
30.4	Example Reports	1230
	30.4.1 <i>An Example of a Portion of a Student Written Report</i>	1231
	30.4.2 <i>An Example of an Improved Student Written Report</i>	1233
30.5	Checklist of Common Mistakes and Errors	1244
	30.5.1 <i>Common Mistakes for Visual Aids</i>	1243
	30.5.2 <i>Common Mistakes for Written Text</i>	1244
Appendix A	Cost Equations and Curves for the CAPCOST Program	1247
A.1	Purchased Equipment Costs	1247
A.2	Pressure Factors	1264
	A.2.1 <i>Pressure Factors for Process Vessels</i>	1264
	A.2.2 <i>Pressure Factors for Other Process Equipment</i>	1264
A.3	Material Factors and Bare Module Factors	1267
	A.3.1 <i>Bare Module and Material Factors for Heat Exchangers, Process Vessels, and Pumps</i>	1267
	A.3.2 <i>Bare Module and Material Factors for the Remaining Process Equipment</i>	1271
	References	1275
Appendix B	Information for the Preliminary Design of Fifteen Chemical Processes	1277
B.1	Dimethyl Ether (DME) Production, Unit 200	1278
	B.1.1 <i>Process Description</i>	1278
	B.1.2 <i>Reaction Kinetics</i>	1282
	B.1.3 <i>Simulation (CHEMCAD) Hints</i>	1283
	B.1.4 <i>References</i>	1283
B.2	Ethylbenzene Production, Unit 300	1283
	B.2.1 <i>Process Description [1, 2]</i>	1284
	B.2.2 <i>Reaction Kinetics</i>	1284
	B.2.3 <i>Simulation (CHEMCAD) Hints</i>	1291
	B.2.4 <i>References</i>	1291
B.3	Styrene Production, Unit 400	1291
	B.3.1 <i>Process Description [1, 2]</i>	1291
	B.3.2 <i>Reaction Kinetics</i>	1292
	B.3.3 <i>Simulation (CHEMCAD) Hints</i>	1299
	B.3.4 <i>References</i>	1299
B.4	Drying Oil Production, Unit 500	1299
	B.4.1 <i>Process Description</i>	1300
	B.4.2 <i>Reaction Kinetics</i>	1300
	B.4.3 <i>Simulation (CHEMCAD) Hints</i>	1300
	B.4.4 <i>Reference</i>	1305

- B.5 Production of Maleic Anhydride from Benzene, Unit 600 1305
 - B.5.1 Process Description 1305
 - B.5.2 Reaction Kinetics 1306
 - B.5.3 Simulation (CHEMCAD) Hints 1311
 - B.5.4 References 1311
- B.6 Ethylene Oxide Production, Unit 700 1311
 - B.6.1 Process Description [1, 2] 1311
 - B.6.2 Reaction Kinetics 1313
 - B.6.3 Simulation (CHEMCAD) Hints 1316
 - B.6.4 References 1317
- B.7 Formalin Production, Unit 800 1317
 - B.7.1 Process Description [1, 2] 1317
 - B.7.2 Reaction Kinetics 1319
 - B.7.3 Simulation (CHEMCAD) Hints 1319
 - B.7.4 References 1319
- B.8 Batch Production of L-Phenylalanine and L-Aspartic Acid, Unit 900 1323
 - B.8.1 Process Description 1323
 - B.8.2 Reaction Kinetics 1325
 - B.8.3 References 1329
- B.9 Acrylic Acid Production via The Catalytic Partial Oxidation of Propylene [1–5], Unit 1000 1329
 - B.9.1 Process Description 1330
 - B.9.2 Reaction Kinetics and Reactor Configuration 1331
 - B.9.3 Simulation (CHEMCAD) Hints 1337
 - B.9.4 References 1337
- B.10 Production of Acetone via the Dehydrogenation of Isopropyl Alcohol (IPA) [1–4], Unit 1100 1338
 - B.10.1 Process Description 1338
 - B.10.2 Reaction Kinetics 1338
 - B.10.3 Simulation (CHEMCAD) Hints 1344
 - B.10.4 References 1344
- B.11 Production of Heptenes from Propylene and Butenes [1], Unit 1200 1344
 - B.11.1 Process Description 1351
 - B.11.2 Reaction Kinetics 1351
 - B.11.3 Simulation (CHEMCAD) Hints 1352
 - B.11.4 Reference 1352
- B.12 Design of a Shift Reactor Unit to Convert CO to CO₂, Unit 1300 1352
 - B.12.1 Process Description 1352
 - B.12.2 Reaction Kinetics 1352
 - B.12.3 Simulation (Aspen Plus) Hints 1356
 - B.12.4 Reference 1356
- B.13 Design of a Dual-Stage Selexol Unit to Remove CO₂ and H₂S From Coal-Derived Synthesis Gas, Unit 1400 1356
 - B.13.1 Process Description 1356
 - B.13.2 Simulation (Aspen Plus) Hints 1358
 - B.13.3 References 1362

B.14	Design of a Claus Unit for the Conversion of H ₂ S to Elemental Sulfur, Unit 1500	1363
B.14.1	Process Description	1363
B.14.2	Reaction Kinetics	1369
B.14.3	Simulation (Aspen Plus) Hints	1370
B.14.4	References	1370
B.15	Modeling a Downward-Flow, Oxygen-Blown, Entrained-Flow Gasifier, Unit 1600	1371
B.15.1	Process Description	1371
B.15.2	Reaction Kinetics	1373
B.15.3	Simulation (Aspen Plus) Hints	1375
B.15.4	References	1377
Appendix C	Design Projects	1379
Project 1	Increasing the Production of 3-Chloro-1-Propene (Allyl Chloride) in Unit 600	1381
C.1.1	Background	1381
C.1.2	Process Description of the Beaumont Allyl Chloride Facility	1382
C.1.3	Specific Objectives of Assignment	1385
C.1.4	Additional Background Information	1386
C.1.5	Process Design Calculations	1388
<i>Fluidized-Bed Reactor, R-601</i>		1388
<i>Reference</i>		1393
Project 2	Design and Optimization of a New 20,000-Metric-Tons-per-Year Facility to Produce Allyl Chloride at La Nueva Cantina, Mexico	1394
C.2.1	Background	1394
C.2.2	Assignment	1394
C.2.3	Problem-Solving Methodology	1395
C.2.4	Process Information	1395
Project 3	Scale-Down of Phthalic Anhydride Production at TBWS Unit 700	1401
C.3.1	Background	1401
C.3.2	Phthalic Anhydride Production	1402
C.3.3	Other Information	1403
C.3.4	Assignment	1411
C.3.5	Report Format	1411
Project 4	The Design of a New 100,000-Metric-Tons-per-Year Phthalic Anhydride Production Facility	1412
C.4.1	Background	1412
C.4.2	Other Information	1412
C.4.3	Assignment	1416
C.4.4	Report Format	1416

Project 5	Problems at the Cumene Production Facility, Unit 800	1417
	C.5.1 Background	1417
	C.5.2 Cumene Production Reactions	1417
	C.5.3 Process Description	1417
	C.5.4 Recent Problems in Unit 800	1418
	C.5.5 Other Information	1420
	C.5.6 Assignment	1420
	C.5.7 Report Format	1420
	C.5.8 Process Calculations	1426
	<i>Calculations for Fuel Gas Exit Line for V-802</i>	1426
	<i>Calculations for P-801</i>	1427
	<i>Vapor Pressure of Stream 3</i>	1428
	<i>Calculations for P-802</i>	1429
Project 6	Design of a New, 100,000-Metric-Tons-per-Year Cumene Production Facility	1430
	C.6.1 Background	1430
	C.6.2 Assignment	1430
	C.6.3 Report Format	1432
<i>Index</i>		1433

Preface

This book represents the culmination of many years of teaching experience in the senior design course at West Virginia University (WVU), Auburn University, and the University of Nevada, Reno. The program at WVU has evolved over the past 30 years and is still evolving, and the authors continue to integrate design throughout the undergraduate curriculum in chemical engineering.

We view design as the focal point of chemical engineering practice. Far more than the development of a set of specifications for a new chemical plant, design is the creative activity through which engineers continuously improve the operations of facilities to create products that enhance the quality of life. Whether developing the grassroots plant, proposing and guiding process modifications, or troubleshooting and implementing operational strategies for existing equipment, engineering design requires a broad spectrum of knowledge and intellectual skills to be able to analyze the big picture and the minute details and, most important, to know when to concentrate on each.

Our vehicle for helping students develop and hone their design skills is process design covering synthesis of the entire chemical process through topics relating to the preliminary sizing of equipment, flowsheet optimization, economic evaluation of projects, and the operation of chemical processes. The purpose of this text is to assist chemical engineering students in making the transition from solving well-posed problems in a specific subject to integrating all the knowledge that they have gained in their undergraduate education and applying this information to solving open-ended process problems.

In the fifth edition, we have replaced the majority of Section IV, Analysis of Process Performance. In previous editions, process performance was explained through a series of increasingly complex case studies. The approach adopted in the fifth edition is to provide a more logical pedagogy for the design of basic process equipment including pipes, pumps, and compressors (Chapter 19); heat exchangers (Chapter 20); separation equipment (Chapter 21); reactors (Chapter 22); and process vessels and steam ejectors (Chapters 23). Each chapter starts out with the design procedure and basic equations needed to design the equipment. At the end of each chapter, examples of performance (or rating) problems are given. The purpose of these chapters is to review the key concepts needed in the design and then show how to analyze systems in which the equipment already exists. It may be tempting to solve the performance of existing equipment using the process simulator, but using steady-state simulators to model these changes in equipment performance can be difficult. Dynamic simulators are the preferred method for simulating performance changes but are rarely used in the undergraduate curriculum. Therefore, we regard the material on equipment performance included in Section IV to be an essential part of the undergraduate design

experience and encourage educators to adopt some if not all of this material in the design course or courses in each specific area that are often taught in the junior year. The content for Chapters 19–23 is taken from the book *Chemical Process Equipment Design* by Turton and Shaeiwitz (ISBN-13: 978-0-13-380447-8).

In addition to the changes in Chapters 19–23, a section on advanced optimization has been added to the chapter on advanced concepts in steady-state simulation (Chapter 16).

The arrangement of chapters into the six sections of the book is similar to that adopted in the fourth edition. These sections are as follows:

- Section I—Conceptualization and Analysis of Chemical Processes
- Section II—Engineering Economic Analysis of Chemical Processes
- Section III—Synthesis and Optimization of Chemical Processes
- Section IV—Chemical Equipment Design and Performance
- Section V—The Impact of Chemical Engineering Design on Society
- Section VI—Interpersonal and Communication Skills

In Section I, the student is introduced first to the principal diagrams that are used to describe a chemical process. Next, the evolution and generation of different process configurations are covered. Key concepts used in evaluating batch processes are included in Chapter 3, and the concepts of product design are given in Chapter 4. Finally, the analysis of existing processes is covered. In Section II, the information needed to assess the economic feasibility of a process is covered. This includes the estimation of fixed capital investment and manufacturing costs, the concepts of the time value of money and financial calculations, and finally the combination of these costs into profitability measures for the process. Section III covers the synthesis of a chemical process. The minimum information required to simulate a process is given, as are the basics of using a process simulator. The choice of the appropriate thermodynamic model to use in a simulation is covered, and the choice of separation operations is covered. Process optimization (including an introduction to optimization of batch processes) and heat integration techniques are covered in this section. In addition, advanced concepts using steady-state process simulators (Chapter 16), the use of dynamic simulators (Chapter 17), and process regulation (Chapter 18) are included in Section III. In Section IV, the analysis of the design of process equipment and the performance of existing process equipment is covered. The presentation of this material has changed substantially from all previous editions and was discussed previously. In Section V, the impact of chemical engineering design on society is covered. The role of the professional engineer in society is addressed. Separate chapters addressing ethics and professionalism, health, safety, and the environment, and green engineering are included. Finally, in Section VI, the interpersonal skills required by the engineer to function as part of a team and to communicate both orally and in written form are covered. An entire chapter is devoted to addressing some of the common mistakes that students make in written reports.

Finally, three appendices are included. Appendix A gives a series of cost charts for equipment. This information is embedded in the CAPCOST program for evaluating fixed capital investments and process economics. Appendix B gives the preliminary design information for 15 chemical processes: dimethyl ether, ethylbenzene, styrene, drying oil, maleic anhydride, ethylene oxide, formalin, batch manufacture of amino acids, acrylic acid, acetone, heptenes production, shift reaction, acid-gas removal by a physical solvent, the removal of H_2S from a gas stream using the Claus process, and finally coal gasification. This information is used in many of the end-of-chapter problems in the book. These processes can also be used as the starting point for more detailed analyses—for example, optimization studies. Other projects, given in Appendix C, are

also included. The reader (faculty and students) is also referred to our Web site at <https://richardturton.faculty.wvu.edu/projects>, where a variety of design projects for sophomore-through senior-level chemical engineering courses is provided. In addition, a revised CAPCOST program is also available at <https://richardturton.faculty.wvu.edu/publications/analysis-synthesis-and-design-of-chemical-processes-5th-edition> as well as the HENSAD program and the virtual plant tour. It should be noted that revisions to the CAPCOST program will appear periodically on the Web site.

The structure of the senior-year design course obviously varies with each instructor. However, the following coverage of materials is offered as suggestions. For a one-semester design course, we recommend including the following core:

- Section I—Chapters 1 through 6
- Section III—Chapters 11, 12, and 13
- Section V—Chapters 25 and 26

For programs in which engineering economics is not covered in a separate course, Section II (Chapters 7–10) should also be included. If students have previously covered engineering economics, Chapters 14 and 15 covering optimization and pinch technology could be substituted. Similarly, for programs that have separate courses on process safety and/or where engineering ethics is treated elsewhere, Chapters 14 and 15 could be substituted.

For the second term of a two-term sequence, we recommend Chapters 19 through 23 (and Chapters 14 and 15 if not included in the first design course) plus a design project. Chapters 19 through 23 could also be the basis for an equipment design course that might precede a process design course. Alternatively, advanced simulation techniques in Chapters 16 and 17 could be covered. If time permits, we also recommend Chapter 18 (Regulation and Control of Chemical Processes with Applications Using Commercial Software) and Chapter 24 (Process Troubleshooting and Debottlenecking), because these tend to solidify as well as extend the concepts of Chapters 19 through 23, that is, what an entry-level process engineer will encounter in the first few years of employment at a chemical process facility. For an environmental emphasis, Chapter 27 could be substituted for Chapters 18 and 24; however, it is recommended that supplementary material be included.

We have found that the most effective way both to enhance and to examine student progress is through oral presentations in addition to the submission of written reports. During these oral presentations, individual students or a student group defends its results to a faculty panel, much as a graduate student defends a thesis or dissertation.

Because design is at its essence a creative, dynamic, challenging, and iterative activity, we welcome feedback on and encourage experimentation with this design textbook. We hope that students and faculty will find the excitement in teaching and learning engineering design that has sustained us over the years.

Finally, we would like to thank those people who have been instrumental to the successful completion of this book. Many thanks are given to all undergraduate chemical engineering students at West Virginia University over the years, particularly the period 1992–2018, and the undergraduate chemical engineering students at Auburn University from 2013–2018. We also acknowledge the many colleagues who have provided, both formally and informally, feedback about this text. In particular, our thanks go to Dr. Susan Montgomery (University of Michigan) and Dr. John Hwalek (University of Maine) for their extensive review of Chapters 19–23 and Dr. Fernando Lima (West Virginia University) for his review of the optimization material in Chapter 16. Finally, RT would like to

thank his wife, Becky; JAS would like to thank his wife, Terry; and DB would like to thank his parents, Sambhunath and Gayatri, wife Pampa, and son Swagat for their continued support, love, and patience during the preparation of this fifth edition.

R.T.
J.A.S.
D.B
W.B.W.

Register your copy of *Analysis, Synthesis, and Design of Chemical Processes, Fifth Edition*, on the InformIT site for convenient access to updates and corrections as they become available. To start the registration process, go to informit.com/register and log in or create an account. Enter the product ISBN (9780134177403) and click Submit. Look on the Registered Products tab for an Access Bonus Content link next to this product, and follow that link to access any available bonus materials. If you would like to be notified of exclusive offers on new editions and updates, please check the box to receive email from us.

About the Authors

Richard Turton, P.E., has taught the design and design-related courses at West Virginia University for the past 32 years. Prior to this, he spent five years in the design and construction industry. His main interests are in design education and process systems modeling.

Joseph A. Shaeiwitz taught design and design-related classes at WVU for more than 25 years. He now teaches design at Auburn University. His interests include design education and outcomes assessment.

Debangsu Bhattacharyya has more than ten years' work experience in a large petroleum refinery. While in the refinery, he worked in process operations, plant start-up, large-scale process simulation, and process control. His main research interests are in process modeling, dynamic simulation, state estimation, sensor placement, and advanced process control.

Wallace B. Whiting, P.E., is professor emeritus at University of Nevada, Reno. He has been involved in the practice and teaching of chemical process design for more than 24 years.

This page intentionally left blank

List of Nomenclature

Symbol	Definition	SI Units
a	Stoichiometric Coefficient	
a	Interfacial, Mass Transfer Area	m^2
a	Mean Ionic Diameter of an Electrolyte	m
a'	Interface Area per Unit Volume	m^2/m^3
A	Equipment Cost Attribute	
A	Area, Heat Transfer Surface Area	m^2
A	Absorption Factor	
A	Annuity Value	\$/time
A	Constant in Antoine's Equation	
$A/F, i, n$	Sinking Fund Factor	
$A/P, i, n$	Capital Recovery Factor	
A_b	Bubbling Area	m^2
A_c	Cross-Sectional Area	m^2
A_t	Total Cross-Sectional Area of Packed Bed	m^2
b	Fin Spacing	m
B	Constant in Antoine's Equation	$^{\circ}C$
BC	Baffle Cut (% of Shell Diameter)	
B_o	Boiling Number	
BV	Book Value	\$
C	Constant in Antoine's Equation	$^{\circ}C$
C	Molar Density	mol/m^3
C	Equipment Cost	\$
C or c	Molar Concentration	$kmol/m^3$
$C_{sb,f}$	Parameter in Flooding Calculation	m/s
CA	Corrosion Allowance	m
CBM	Bare Module Cost	\$
C_D	Drag Coefficient	
C_f	Material Constant for Surfaces Used in Boiling Heat Transfer	
COM	Cost of Manufacture	\$/time
cop	Coefficient of Performance	
C_p, C_v	Heat Capacities (Constant Pressure, Constant Volume)	$kJ/kg^{\circ}C$ or $kJ/kmol^{\circ}C$

CCP	Cumulative Cash Position	\$
CCR	Cumulative Cash Ratio	
D, D_{AB}	Diffusivity, Diffusion Coefficient of Solute A in Solution B	m^2/s
d, D	Diameter	m
D^*	Dimensionless Diameter	
D	Amount Allowed for Depreciation	\$
D	Distillate Product Flowrate	kmol/time
d	Yearly Depreciation Allowance	\$/yr
DCFROR	Discounted Cash Flow Rate of Return	
DMC	Direct Manufacturing Cost	\$/time
DPBP	Discounted Payback Period	years
\bar{D}	Average Diffusivity	m^2/s
D_0	Diffusivity at Infinite Dilution	m^2/s
D_p, D_s	Particle Diameter, Sphere Diameter	m
\mathbf{d}	Vector of Disturbance Inputs	
d_s	Average Solvent Density	kg/m^3
e	Elementary Charge	Columb
e	Pipe Roughness Factor	m
e_f	Energy Dissipated by Friction	J/kg
E	Money Earned	\$
E	Weld Efficiency	
$E(t)$	Residence Time Distribution in Reactor	s^{-1}
E_{act} or E	Activation Energy	$kJ/kmol$
E_o	Overall Column Efficiency	
EAOC	Equivalent Annual Operating Cost	\$/yr
ECC	Equivalent Capitalized Cost	\$
f	Fraction of Stream	
f	Friction Factor	
f	Rate of Inflation	
f	Factor Used in Convective Boiling Correlation	
f_q	Quantity Factors for Trays	
F	Faraday's Constant	Columb/kmol
F	Future Value	\$
F	Molar Flowrate	kmol/s, kmol/h
F	Equipment Module Cost Factor	
F	Correction for Multipass Heat Exchangers	
F	Force	N
F	Packing Factor in Packed Beds	
F_{bv}	Parameter in Flooding Calculation	
F_d, F_g, F_p	Drag, Gravitational, and Pressure Force	N/m^2 or kPa
F_x, F_y	Mass Transfer Coefficients for Liquid (x) or Vapor (y) Phase	m/s
$F/A, i, n$	Uniform Series Compound Amount Factor	
FCI	Fixed Capital Investment	\$
$F/P, i, n$	Single Payment Compound Amount Factor	
FMC	Fixed Manufacturing Costs	\$/time
F_{Lang}	Lang Factor	
f_i	Fugacity of Pure Component i	bar or kPa

\hat{f}_i	Fugacity of Component i in Mixture	bar or kPa
\mathbf{f}	System of Equations (vector)	
g	Acceleration Due to Gravity	m/s^2
g_c	Unit Conversion of 32.2 ft lb/lb _f /sec ²	ft lb/lb _f /sec ²
G, G'	Superficial Mass Velocity	kg/m ² /s
G	Gibbs Free Energy	kJ
G	Gas Flowrate	kg/s, kmol/s
GE	General Expenses	\$/time
h	Individual Heat Transfer Coefficient	W/m ² /K
H, H_A	Henry's Law Constant	bar or kPa in Equation (13.5), but can be different elsewhere
H, h	Enthalpy, Specific Enthalpy	kJ or kJ/kg
H or h	Height or Head	m
H, HTU	Height of Transfer Unit	m
$HETP$	Height Equivalent of a Theoretical Plate	m
h_f	Height of Froth on a Tray	m
h_{mf}	Bed Height at Minimum Fluidization	m
\mathbf{I}	Identity Matrix	
I	Ionic Concentration	kmol/m ³
I_x	Ionic Strength on a Mole Fraction Basis	
I	Cost Index	
i	Compound Interest	
i'	Effective Interest Rate Including Inflation	
$INPV$	Incremental Net Present Value	\$
$IPBP$	Incremental Payback Period	years
\mathbf{J}	Jacobian Matrix	
k	Thermal Conductivity	W/m K
k	Ratio of Specific Heat Capacities of a Gas	
k_o, K	Preexponential Factor for Reaction Rate Constant	Depends on molecularity of reaction
K	Loss Coefficient for Elbows, Fittings, etc.	
K_p	Equilibrium Constant	Depends on reaction stoichiometry
k_B	Boltzmann Constant	kJ/K
\bar{k}_m	Average Mass Transfer Coefficient	m/s
k_{reac} or k_i	Reaction Rate Constant	Depends on molecularity of reaction
k_{SB}	Souders-Brown Constant	m/s
K	Geometric Factor for Elliptical Heads	
K_c	Proportional Gain	
K_{cu}	Ultimate Controller Gain	
K_{eq}	Equilibrium Constant of a Chemical Reaction	
K_i	Vapor-Liquid Equilibrium Ratio of Species i	
K_x, K_y	Mass Transfer Coefficient (x is Liquid Phase, y is Vapor Phase)	kmol/m ² /s
L	Lean Stream Flowrate	kg/s

L	Length (also Baffle Spacing), Characteristic Length of a Catalyst Particle	m
L_{eq}	Equivalent Length of Pipe	m
L, \bar{L}	Liquid Flowrate (Over Bar signifies Below Feed in Distillation Column)	kg/s or kmol/s
\dot{m}	Mass Flowrate	kg/s
m	Equilibrium/Partition Coefficient (y/x)	
m	Molality	kmol/kg
m	Parameter Used in Fin Effectiveness, $m = (2h / \delta k)^{1/2}$ for Rectangular Fins, etc.	
m, M	Ratio of Tube Side and Shell Side Flows in Performance Problems	
M, m_w	Molecular Weight	kg/kmol
M	Mass	kg
M	Stress Intensity Factor for Dished Heads	
M_T	Thiele Modulus	
n	Life of Equipment	years
n	Years of Investment	years
n	Number of Batches	
n_c	Number of Campaigns	
N	Number of Streams, Trays, Stages, Transfer Units, Shells, etc.	
N_u	Nusselt Number	
N	Molar Flowrate or Molar Flux	kmol/s or kmol/m ² /s
$NPSH_A$	Net Positive Suction Head (Available, Required)	m of liquid (or Pa)
$NPSH_R$		
NPV	Net Present Value	\$
N_{toG}	Number of Transfer Units	
N	Molar Holdup	kmol
OBJ, OF	Objective Function	usually \$ or \$/time
p	Tube Pitch (Distance between Centers of Adjacent Tubes)	m
p	Price	\$
p_i	Partial Pressure	Pa
P	Dimensionless Temperature Approach Used in Log-Mean Temperature Correction Factor	
P, p	Pressure and Partial Pressure	bar or kPa
P	Present Value	\$
P^*	Vapor Pressure	bar or kPa
P_i	Membrane Permeability of Component i	m ³ /m ² /s/kPa
$P/A, i, n$	Uniform Series Present Worth Factor	
PBP	Payback Period	year
PC	Project Cost	\$
$P/F, i, n$	Single Payment Present Worth Factor	
PVR	Present Value Ratio	
$P(x)$	Probability Density Function of x	
Pr	Prandtl Number	
P_u	Ultimate Period of Oscillation	s
Q or q	Rate of Heat Transfer or Heat Duty	W or MJ/h
q	Fraction of Liquid in Distillation Column Feed	

\dot{Q}	Heat Transfer Rate	W or MJ/h
r	Radius	m
r	Reaction Rate	kmol/m ³ or kmol/kg cat s
r	Rate of Production	kg/h
r_k	Knuckle Radius for Dished Heads	m
R	Gas Constant	kJ/kmol K
R	Ratio of Heat Capacities Used in Log-Mean Temperature Correction Factor	
R	Residual Funds Needed	\$
R	Reflux Ratio	
R	Heat Transfer Resistance	m ² K/W
R	Restoring Force to Keep Elbow (pipe fitting) Stationary	N
Re	Reynolds Number	
Re_{emf}	Reynolds Number at Minimum Fluidization	
Re_t	Reynolds Number at Terminal Velocity	
R	Rich Stream Flowrate	kg/s
Rand	Random Number	
ROROI	Rate of Return on Investment	% p.a.
ROROI _I	Rate of Return on Incremental Investment	% p.a.
s	Suppression Factor Used in Convective Boiling Correlation	
S	Entropy	kJ/K
S	Salvage Value	\$
S	Maximum Allowable Working Pressure	bar
S	Salt Concentration Factor	
S	Sensitivity	
S	Interfacial Surface Area	m ²
S	Stripping Factor	
SF	Stream Factor	
t	Thickness of Wall	m
t	Time	s, min, h, yr
\bar{t}	Average Time Spent in Reactor	s
t_m	Membrane Thickness	m
T_m	Melting Temperature	K
T	Total Time for a Batch	s, min, h, yr
T	Temperature	K, R, °C, or °F
U	Internal Energy	kJ
\mathbf{u}	Vector of Manipulated Inputs	
u	Flow Velocity	m/s
u_t^*	Dimensionless Terminal Velocity	
u_s	Superficial Velocity in Packed or Fluidized Bed	m/s
u_t	Terminal Velocity of a Particle	m/s
U	Overall Heat Transfer Coefficient	W/m ² K
U	Internal Energy	J
v	Molar Volume	m ³ /mol
V	Volume	m ³
V, \bar{V}	Vapor Flow Rate (Over Bar is Below Feed in Distillation Column)	kmol/h
v_{react}	Specific Volume of Reactor	m ³ /kg of product

v_p	Velocity	m/s
\dot{v}	Volumetric Flowrate	m ³ /s
W	Weight	kg
W	Total Moles of a Component	kmol
W	Width of Heat Transfer Fin	m
W or W_s	Work or Shaft Work	kJ/kg
\dot{W}_s	Shaft Power	W
WC	Working Capital	\$
\mathbf{X}	Matrix of Independent Variables	
\mathbf{x}	Vector of Variables	
x	Mole or Mass Fraction	
x	Wall or Film Thickness	m
x	Mole Fraction in Liquid Phase	
X	Conversion	
X	Base-Case Ratio	
X_{tp}	Martinelli's Two-Phase Flow Parameter	
y	Mole or Mass Fraction (in Vapor Phase)	
Y	Yield	
YOC	Yearly Operating Cost	\$/yr
YS	Yearly Cash Flow (Savings)	\$/yr
z	Valence of Ions	
z	Solids Mole Fraction, Mole Fraction in Feed Stream	
z	Distance or level	m
z	Coordinate in Direction Opposite Gravity	M

Greek Symbols

α	Multiplication Cost Factor	
α_{AB}	Relative Volatility or Relative Permeability (between Species A and B)	
α	NRTL Nonrandomness Factor	
α	Parameter in Calculating Pressure Drop in Packed Bed	
β	Parameter in Calculating Pressure Drop in Packed Bed	
β	Orifice Diameter/Pipe Diameter	
δ	Thickness of the Ion-Free Layer below	
δ	(Condensing) Film Thickness or Fin Thickness	m
ε	Void Fraction	
ε	Pump Efficiency	
ε	Tolerance, Error	
ε	Emissivity	
ε	Effectiveness (for fins)	
ε_{ij}	Lennard-Jones Energy Parameter between Species i and j	kJ/kmol
ε_r	Relative Permittivity of the Solvent	
ε_r'	Relative Permittivity of the Vapor Phase	
ε_s	Permittivity of the Solvent	Columb ² /kJ m
ϕ	Fugacity Coefficient	
$\hat{\phi}$	Fugacity Coefficient in Mixture	
ϕ^*	Fugacity Coefficient of Saturated Vapor	
γ	Activity Coefficient	

γ	Ratio of Heat Capacities = C_p/C_v	
γ^∞	Activity Coefficient in the Mixture at Infinite Dilution	
γ_{\pm}	Mean Ionic Activity Coefficient	
κ	Inverse of Debye-Hückel Length	m^{-1}
η	Catalyst Effectiveness Factor	
η	Selectivity	
$\eta, \eta_c, \eta_f, \eta_p, \eta_t$	Efficiency for Compressor, Separator, Pump, Turbine	
λ	Heat of Vaporization	kJ/kg
λ	Eigenvalue	
λ	Heat of Vaporization/Condensation	kJ/kg
λ	Lagrangian Multiplier Vector	
λ_0	Thermal Conductivity of Pure Solvent	$W/m K$
μ	Viscosity	$kg/m s$
μ_c	Chemical Potential	kJ
μ_0	Viscosity of Pure Solvent	$kg/m s$
ν	Stoichiometric Coefficient	
θ	Parameter Vector	
θ	Ratio of Species Concentration to That of Limiting Reactant	
θ	Angle	$^\circ$ or rad
θ	Stage Cut in Gas Permeation Membrane	
σ	Statistical Variance	
σ	Collision Diameter	m
σ	Surface Tension	N/m ($dyne/cm^2$)
σ	Stefan-Boltzmann Constant	$W/m^2/K^4$
ξ	Selectivity	
ρ, ρ_s	Density, Solid (Particle) Density	kg/m^3
Θ	Stoichiometric Parameter	
Θ	Cycle Time	s
τ	Space Time	s
τ	NRTL Binary Interaction Energy Parameter	
τ_D	Derivative Time Constant	s
τ_I	Integral Time Constant	s
ψ	Density of Water/Density of Liquid in Packed Bed	
Ψ	Sphericity	
Ψ	Inertial Separation Parameter	
Ω	Overall Catalyst Effectiveness (Including Internal and External Resistances)	
Ω	Collision Integral	

Subscripts

1	Base Time, Base Case, or Inlet Condition
2	Desired Time, New Case, or Outlet Condition
<i>a</i>	Required Attribute
<i>air-leak</i>	Air Leak Due to Vacuum Conditions
A, B, R, S	Designating Components A, B, R, S
ACT, <i>actual</i>	Actual
<i>Active</i>	Refers to Active Column Area

<i>Aux</i>	Auxiliary Buildings
<i>a, a'</i>	Anion
<i>b</i>	Base Attribute, Baffle
<i>b</i>	Bulk or Bubble Phase
<i>bare</i>	Bare Fin
<i>base</i>	Fin Base
<i>B</i>	Bottoms of Distillation Column
<i>BM</i>	Bare Module
<i>c, c'</i>	Cation
<i>c</i>	Cold, Corrected, Critical, Coolant
<i>cb</i>	Convective Boiling
<i>cat</i>	Catalyst
<i>clean</i>	Cleaning
<i>cocurrent</i>	Designating a Cocurrent Arrangement for an S-T Heat Exchanger
<i>countercurrent</i>	Designating a Countercurrent Arrangement for an S-T Heat Exchanger
<i>Cont</i>	Contingency
<i>C</i>	Refers to Condenser
<i>cv</i>	Control Volume
<i>cw</i>	Cooling Water
<i>cycle</i>	Cycle
<i>d</i>	Without Depreciation
<i>dished</i>	Dished Vessel Head
<i>elliptical</i>	Elliptical Vessel Head
<i>D, d</i>	Demand
<i>D</i>	Distillate
<i>E</i>	Emulsion Phase
<i>E</i>	Contractor Engineering Expenses
<i>eff</i>	Effective
<i>eq</i>	Equivalent
<i>el</i>	Electrolyte(s)
<i>eq</i>	Metal in the Equipment
<i>f</i>	Flooding Conditions
<i>fb</i>	Film Boiling
<i>fin</i>	Fin
<i>film</i>	Film
<i>F, f</i>	Feed
<i>Fee</i>	Contractor Fee
<i>FTT</i>	Transportation, etc.
<i>g</i>	Gas
<i>GR</i>	Grass Roots
<i>h</i>	Hot
<i>H</i>	Hydraulic
<i>i</i>	Species
<i>i</i>	Index, Inside, or Interface
<i>in</i>	Inlet or Inner
<i>int</i>	Internal
<i>k</i>	Year
<i>lm</i>	Log-Mean
<i>l-h</i>	Liquid Holdup
<i>l, L</i>	Liquid

L	Installation Labor
L	Lean Streams
L	Without Land Cost
LF	Long-Range Force
m	Molality Scale
m	Mass Transfer
m	Molecular Species
m	Heating/Cooling Medium or Membrane
m	Number of Years
M	Materials for Installation
M	Material Cost Factor
max	Maximum
MC	Matching Costs
mesh	Mesh
min	Minimum
n	Index for Time Instant
nom	Nominal Interest
o	Outside
out	Outlet
O or OH	Construction Overhead
Off	Offsites and Utilities
OL	Operating Labor
OL, OV, ov	Overall Liquid and Overall Vapor Transfer Units or Height of Transfer Unit, Respectively
opt	Optimum
p	Production
p	Process Stream or Permeate Stream
pb	Pool Boiling
P	Equipment at Manufacturer's Site (Purchased), Pressure Cost Factor, Process or Particle
P&I	Piping and Instrumentation
rev	Reversible
rxn, r	Reaction
r	Reduced (Pressure)
r	Retenate Stream
rad	Radiation
R	Rich Stream, Reboiler, Reference
RM	Raw Materials
s	All Nonwater Solvents, Simple Interest, Surface, or Stream
sat	Saturated
s, shell	Shell (Side) of Heat Exchanger
S	Supply
SB	Souders-Brown
Site	Site Development
SF	Short-Range Force
sph	Spherical or Equivalent Spherical
t, tube	Tube (Side) of Heat Exchanger
t	Terminal
tp	Tube Passes
TM	Total Module

<i>UT</i>	Utilities
<i>V, v</i>	Vapor
<i>vap</i>	Vaporization
<i>ves</i>	Vessel
<i>wire</i>	Wire
<i>WT</i>	Waste Treatment
<i>w</i>	Water or Wall
<i>y</i>	Designation for Type in Effectiveness Factor for Heat Exchangers, $y = 1-2, 2-4, 3-6$, etc.
<i>z</i>	Distance Along Reactor or Tube
<i>+</i>	Cation
<i>-</i>	Anion

Superscripts

α, β	Powers of Coefficients in Langmuir-Hinshelwood Kinetics
<i>a, b</i>	Powers in Simple Rate Laws
<i>DB</i>	Double Declining Balance Depreciation
<i>E or ex</i>	Excess Property
<i>L</i>	Lower Limit
<i>L, l</i>	Liquid
*	Equilibrium Value
<i>o</i>	Cost for Ambient Pressure Using Carbon Steel
<i>s</i>	Solid
<i>SL</i>	Straight Line Depreciation
<i>SOYD</i>	Sum of the Years Depreciation
<i>U</i>	Upper Limit
<i>v</i>	Vapor
∞	Aqueous Infinite Dilution
'	Includes Effect of Inflation on Interest
'''	Signifies Reaction Rate Per Unit Mass of Catalyst

Additional Nomenclature

Table 1.2	Convention for Specifying Process Equipment
Table 1.3	Convention for Specifying Process Streams
Table 1.7	Abbreviations for Equipment and Materials of Construction
Table 1.10	Convention for Specifying Instrumentation and Control Systems

Note: In this book, matrices are denoted by boldface, uppercase, italicized letters and vectors are denoted by boldface, lowercase, italicized letters.

Chemical Equipment Design and Performance Process Equipment Design and Performance

The previous three sections focused on problems associated with the design, synthesis, and economics of a new chemical process, with less emphasis on equipment design. This section involves the design of new equipment and the performance of existing equipment in a chemical process. Three important factors must be understood:

1. In equipment design, the input and desired output are known, and the piece of equipment is designed to ensure that the output can be obtained from the input.
2. In equipment performance, the input and equipment specifications are known, and the output is calculated. Therefore, changes are limited by the performance of the existing equipment.
3. Any changes in operation of the process cannot be considered in isolation. The impact on the total process must always be considered.

Over the 10 to 30 years or more a plant is expected to operate, process operations may vary. A plant seldom operates at the original process conditions provided on the design PFD. This is due to the following:

- **Design/Construction:** Installed equipment is often oversized. This reduces risks resulting from inaccuracies in design correlations, uncertainties in material properties, and so on.
- **External Effects:** Feed materials, product specifications and flowrates, environmental regulations, and costs of raw materials and utilities all are likely to change during the life of the process.
- **Replacement of Equipment:** New and improved equipment (or catalysts) may replace existing units in the plant.
- **Changes in Equipment Performance:** In general, equipment effectiveness degrades with age. For example, heat transfer surfaces foul, packed towers develop channels, catalysts lose activity, and bearings on pumps and compressors become worn. Plants are shut down periodically for maintenance to restore equipment performance.

To remain competitive, it is necessary to be able to alter process operations in response to changing conditions. Therefore, it is necessary to understand how equipment performs over its complete operating range to quantify the effects of changing process conditions on process performance.

The material provided in this section involves several categories of design and performance problems:

1. **Design Problems:** The design of typical chemical process equipment is presented, and the equipment constraints and limitations are discussed.
2. **Predictive Problems:** An examination of the changes that take place for a change in process or equipment input and/or a change in equipment effectiveness.
3. **Diagnostic/Troubleshooting Problems:** If a change in process output (process disturbance or upset) is observed, the cause (change in process input, change in equipment performance) must be identified.
4. **Debottlenecking Problems:** Often, a process change is necessary or desired, such as scale-up (increasing production capacity) or allowance for a change in product or raw material specifications. Identification of the equipment that limits the ability to make the desired change or constrains the change is necessary.

This section introduces the basic principles by which existing equipment and processes are designed, evaluated, operated, controlled, and subjected to changes in operating conditions. This material is treated in the following chapters.

Chapter 19: Process Fluid Mechanics

The basic design of pumps, pipes, etc., is presented for incompressible and compressible flows. The performance of pumps and existing piping systems is also presented.

Chapter 20: Process Heat Transfer

The basic design of heat exchange equipment is presented. The need for multiple shell-pass heat exchangers is discussed based on the LMTD correction factor. An extensive treatment of heat transfer coefficients for typical process situations, including boiling and condensation, is included. The performance of existing heat transfer equipment is also presented.

Chapter 21: Separation Equipment

The basics of typical chemical engineering separations (distillation, absorption, stripping, extraction) are reviewed, but not with the depth found in standard separation textbooks. The equipment design characteristics are emphasized. The performance of existing separation equipment is also presented.

Chapter 22: Reactors

The basics of reaction engineering are reviewed, but not with the depth found in standard reaction engineering textbooks. "Real" reactor configurations are discussed in depth. The performance of existing reactors is also presented.

Chapter 23: Other Equipment

The design and performance of pressure vessels, knockout drums, and steam ejectors is presented.

Chapter 24: Process Troubleshooting and Debottlenecking

Case studies are presented to introduce the philosophy and methodology for process troubleshooting and debottlenecking.

Process Fluid Mechanics

WHAT YOU WILL LEARN

- The basic relationships for fluid flow—mass, energy, and force balances
- The primary types of fluid flow equipment—pipes, pumps, compressors, valves
- How to design a system for incompressible and compressible frictional flow of fluid in pipes
- How to design a system for frictional flow of fluid with submerged objects
- Methods for flow measurement
- How to analyze existing fluid flow equipment
- How to use the concept of net positive suction head (NPSH) to ensure safe and appropriate pump operation
- The analysis of pump and system curves
- How to use compressor curves and when to use compressor staging

The purpose of this chapter is to introduce the concepts needed to design piping systems, including pumps, compressors, turbines, valves, and other components, and to evaluate the performance of these systems once designed and implemented. The scope is limited to steady-state situations. Derivations are minimized, and the emphasis is on providing a set of useful, working equations that can be used to design and evaluate the performance of piping systems.

19.1 BASIC RELATIONSHIPS IN FLUID MECHANICS

In expressing the basic relationships for fluid flow, a general control volume is used, as illustrated in Figure 19.1. This control volume can be the fluid inside the pipes and equipment connected by the pipes, with the possibility of multiple inputs and multiple outputs. For the simple case of one input and one output, the subscript 1 refers to the upstream side and the subscript 2 refers to the downstream side.

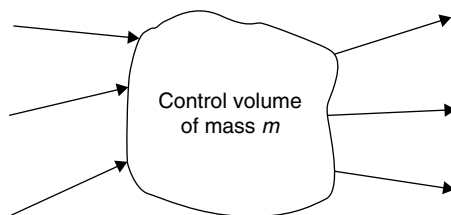

Figure 19.1 General Control Volume

19.1.1 Mass Balance

At steady state, mass is conserved, so the total mass flowrate (\dot{m} , mass/time) in must equal the total mass flowrate out. For a device with m inputs and n outputs, the appropriate relationship is given by Equation (19.1). For a single input and single output, Equation (19.2) is used.

$$\sum_{i=1}^m \dot{m}_{i,in} = \sum_{i=1}^m \dot{m}_{i,out} \quad (19.1)$$

$$\dot{m}_1 = \dot{m}_2 \quad (19.2)$$

In describing fluid flow, it is necessary to write the mass flowrate in terms of both volumetric flowrate (\dot{v} , volume/time) and velocity (u , length/time). These relationships are

$$\dot{m} = \rho \dot{v} = \rho Au \quad (19.3)$$

where ρ is the density (mass/volume) and A is the cross-sectional area for flow (length²). From Equation (19.3), for an incompressible fluid (constant density) at steady state, the volumetric flowrate is constant, and the velocity is constant for a constant cross-sectional area for flow. However, for a compressible fluid flowing with constant cross-sectional area, if the density changes, the volumetric flowrate and velocity both change in the opposite direction, since the mass flowrate is constant. Accordingly, if the density decreases, the volumetric flowrate and velocity both increase. For problems involving compressible flow, it is useful to define the superficial mass velocity, G (mass/area/time), as

$$G = \frac{\dot{m}}{A} = \rho u \quad (19.4)$$

The advantage of defining a superficial mass velocity is that it is constant for steady-state flow in a constant cross-sectional area, unlike density and velocity, and it shows that the product of density and velocity remains constant.

For a system with multiple inputs and/or multiple outputs at steady state, as is illustrated in Figure 19.2, the total mass flowrate into the system must equal the total mass flowrate out,

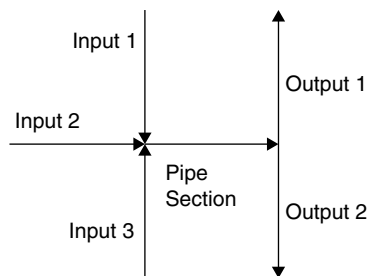

Figure 19.2 System with Multiple Inputs and Outputs

Equation (19.1). However, the output mass flowrate in each section differs depending on the size, length, and elevation of the piping involved. These problems are discussed later.

Example 19.1

Two streams of crude oil (specific gravity of 0.887) mix as shown in Figure E19.1. The volumetric flowrate of Stream 1 is $0.006 \text{ m}^3/\text{s}$, and its pipe diameter is 0.078 m . The volumetric flowrate of Stream 2 is $0.009 \text{ m}^3/\text{s}$, and its pipe diameter is 0.10 m .

- Determine the volumetric and mass flowrates of Stream 3.
- Determine the velocities in Streams 1 and 2.
- If the velocity is not to exceed 1 m/s in Stream 3, determine the minimum possible pipe diameter.
- Determine the superficial mass velocity Stream 3 using the pipe diameter calculated in Part (c).

Solution

- Since the density is constant, the volumetric flowrate of Stream 3 is the sum of the volumetric flowrates of Streams 1 and 2, $0.015 \text{ m}^3/\text{s}$. To obtain the mass flowrate, $\dot{m} = \rho \dot{v}$, so $\dot{m}_3 = (887 \text{ kg/m}^3)(0.015 \text{ m}^3/\text{s}) = 13.3 \text{ kg/s}$. Alternatively, the mass flowrate of Streams 1 and 2 could be calculated and added to get the same result.
- From Equation (19.3), at constant density $u = \dot{v}/A$. Therefore,

$$u_1 = \frac{\dot{v}_1}{A_1} = \frac{4\dot{v}_1}{\pi D_1^2} = \frac{4(0.006 \text{ m}^3/\text{s})}{\pi(0.078 \text{ m})^2} = 1.26 \text{ m/s} \quad (\text{E19.1a})$$

$$u_2 = \frac{\dot{v}_2}{A_2} = \frac{4\dot{v}_2}{\pi D_2^2} = \frac{4(0.009 \text{ m}^3/\text{s})}{\pi(0.10 \text{ m})^2} = 1.15 \text{ m/s} \quad (\text{E19.1b})$$

- The diameter at which $u_3 = 1 \text{ m/s}$ can be calculated from Equation (19.3) at constant density.

$$\dot{v}_3 = u_3 A_3 \Rightarrow 0.015 \text{ m}^3/\text{s} = (1 \text{ m/s}) \left(\frac{\pi D^2}{4} \right) \therefore D = 0.138 \text{ m} \quad (\text{E19.1c})$$

If the diameter were smaller, the cross-sectional area would be smaller, and from Equation (19.3), the velocity would be larger. Hence, the result in Equation (E19.1c) is the minimum possible diameter. As shown later, actual pipes are available only in discrete sizes, so it is necessary to use the next higher pipe diameter.

- From Equation (19.4), using the rounded values,

$$G_1 = \frac{\dot{m}_3}{A_3} = \frac{4\dot{m}_3}{\pi D_1^2} = \frac{4(13.3 \text{ kg/s})}{\pi(0.138 \text{ m})^2} = 889.2 \text{ kg/m}^2/\text{s} \quad (\text{E19.1d})$$

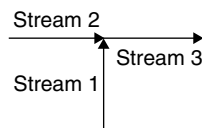

Figure E19.1 Physical Situation in Example 19.1

19.1.2 Mechanical Energy Balance

The mechanical energy balance represents the conversion between different forms of energy in piping systems. With the exception of temperature changes for a gas undergoing compression or expansion with no phase change, temperature is assumed to be constant. The mechanical energy balance is

$$\int_1^2 \frac{dP}{\rho} + \frac{1}{2} \Delta \left(\frac{\langle u^3 \rangle}{\langle u \rangle} \right) + g\Delta z + e_f - W_s = 0 \quad (19.5)$$

In Equation (19.5) and throughout this chapter, the difference, Δ , represents the value at Point 2 minus the value at Point 1, that is, out – in. The units in Equation (19.5) are energy/mass or length²/time². In SI units, since 1 J = 1 kg m²/s², it is clear that 1 J/kg = 1 m²/s². In American Engineering units, since 1 lb_f = 32.2 ft lb_m/sec², this conversion factor (often called g_c) must be used to reconcile the units. The notation $\langle \rangle$ represents the appropriate average quantity.

The first term in Equation (19.5) is the enthalpy of the system. On the basis of the constant temperature assumption, only pressure is involved. For incompressible fluids, such as liquids, density is constant, and the term reduces to

$$\int_1^2 \frac{dP}{\rho} = \frac{\Delta P}{\rho} \quad (19.6)$$

For compressible fluids, the integral must be evaluated using an equation of state.

The second term in Equation (19.5) is the kinetic energy term. For turbulent flow, a reasonable assumption is that

$$\frac{\langle u^3 \rangle}{\langle u \rangle} \approx \langle u \rangle^2 \quad (19.7)$$

For laminar flow,

$$\frac{\langle u^3 \rangle}{\langle u \rangle} \approx 2 \langle u \rangle^2 \quad (19.8)$$

For simplicity, $\langle u^2 \rangle$ is hereafter represented as $\langle u \rangle^2$, which is shortened to u^2 .

The third term in Equation (19.5) is the potential energy term. Based on the general control volume, Δz is positive if Point 2 is at a higher elevation than Point 1.

The fourth term in Equation (19.5) is often called the energy “loss” due to friction. Of course, energy is not lost—it is just expended to overcome friction, and it manifests as a change in temperature. The procedures for calculating frictional losses are discussed later.

The last term in Equation (19.5) represents the shaft work, that is, the work done on the system (fluid) by a pump or compressor or the work done by the system on a turbine. These devices are not 100% efficient. For example, more work must be applied to the pump than is transferred to the fluid, and less work is generated by the turbine than is expended by the fluid. In this book, work is defined as positive if done on the system (pump, compressor) and negative if done by the fluid (turbine). This convention is consistent with the flow of energy in or out of the system; however, many textbooks use the reverse sign convention. Equipment such as pumps, compressors, and turbines are described in terms of their power, where power is the rate of doing work. Therefore, a device power (\dot{W}_s , energy/time) is defined as the product of the mass flowrate (mass/time) and the shaft work (energy/mass):

$$\dot{W}_s = \dot{m}W_s \quad (19.9)$$

When efficiencies are included, the last term in Equation (19.5) becomes

$$\eta_p W_s = \frac{\eta_p \dot{W}_s}{\dot{m}} \text{ pump/compressor} \quad (19.10)$$

$$\frac{W_s}{\eta_t} = \frac{\dot{W}_s}{\eta_t \dot{m}} \text{ turbine} \quad (19.11)$$

Example 19.2

Water in an open (source or supply) tank is pumped to a second (destination) tank at a rate of 5 lb/sec with the water level in the destination tank 25 ft above the water level in the source tank, and it is assumed that the water level does not change with the flow of water. The destination tank is under a constant 30 psig pressure. The pump efficiency is 75%. Neglect friction.

- Determine the required horsepower of the pump.
- Determine the pressure increase provided by the pump assuming the suction and discharge lines have the same diameter.

Solution

- Turbulent flow in the pipes is assumed. The mechanical energy balance is

$$\frac{\Delta P}{\rho} + \frac{1}{2} \Delta u^2 + g \Delta z + e_f - \frac{\eta_p \dot{W}_s}{\dot{m}} = 0 \quad (\text{E19.2a})$$

Figure E19.2 is an illustration of the system.

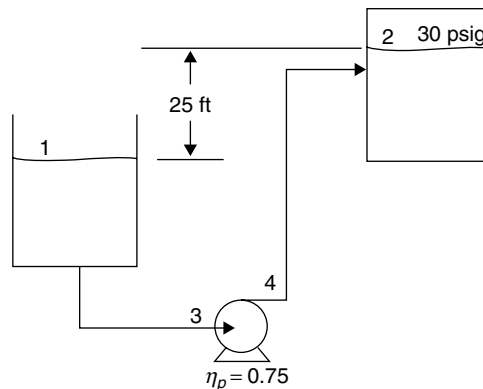

Figure E19.2 Physical Situation for Example 19.2

The control volume is the water in the tanks, the pipes, and the pump, and the locations of Points 1 and 2 are illustrated. The integral in the first term of Equation (19.2) is simplified to the first term in Equation (E19.2a), since the density of water is a constant. In general, the fluid velocity in tanks is assumed to be zero because tank diameters are much larger than pipe diameters, so the kinetic energy term for the liquid surface in the tank is essentially zero. Any fluid in contact with the atmosphere is at atmospheric pressure, so $P_1 = 1 \text{ atm} = 0 \text{ psig}$. The friction term is assumed to be zero in this problem, as stated. So, Equation (E19.2a) reduces to

$$\frac{P_2 - P_1}{\rho} + g(z_2 - z_1) - \frac{\eta_p \dot{W}_s}{\dot{m}} = 0 \quad (\text{E19.2b})$$

and

$$\frac{(30-0) \text{ lb}_f/\text{in}^2 (12 \text{ in}/\text{ft})^2}{62.4 \text{ lb}/\text{ft}^3} + \frac{32.2 \text{ ft}/\text{sec}^2}{32.2 \text{ ft lb}/\text{lb}_f/\text{sec}^2} (25-0) \text{ ft} - \frac{0.75 \dot{W}_s}{5 \text{ lb}/\text{sec}} = 0 \quad (\text{E19.2c})$$

so, $\dot{W}_s = 628.2 \text{ ft lb}_f/\text{sec}$.

Converting to horsepower yields

$$\dot{W}_s = \frac{628.2 \text{ ft lb}_f/\text{sec}}{550 \text{ ft lb}_f/\text{hp}/\text{sec}} = 1.14 \text{ hp} \quad (\text{E19.2d})$$

- b. To determine the pressure rise in the pump, the control volume is now taken as the fluid in the pump. So, the mechanical energy balance is written between Points 3 and 4. The mechanical energy balance reduces to

$$\frac{\Delta P}{\rho} - \frac{\eta_p \dot{W}_s}{\dot{m}} = 0 \quad (\text{E19.2e})$$

The kinetic energy term is zero because the suction and discharge pipes have the same diameter. Frictional losses are assumed to be zero in this example. The potential energy term is also assumed to be zero across the pump; however, since the discharge line of a pump may be higher than the suction line, in a more detailed analysis, that potential energy difference might be included. Solving

$$\frac{P(\text{lb}_f/\text{in}^2)(12 \text{ in}/\text{ft})^2}{62.4 \text{ lb}/\text{ft}^3} - \frac{0.75(628.2 \text{ ft lb}_f/\text{sec})}{5 \text{ lb}/\text{sec}} = 0 \quad (\text{E19.2f})$$

gives $\Delta P = 40.8 \text{ lb}_f/\text{in}^2$.

Example 19.3

A nozzle is a device that converts pressure into kinetic energy by forcing a fluid through a small-diameter opening. Turbines work in this way because the fluid (usually a gas) with a high kinetic energy impinges on turbine blades, causing spinning, and allowing the energy to be converted to electric power.

Consider a nozzle that forces 2 gal/min of water at 50 psia in a tube of 1-in inside diameter through a 0.1-in nozzle from which it discharges to atmosphere. Calculate the discharge velocity.

Solution

The system is illustrated in Figure E19.3. It is assumed that the velocity at a small distance from the end of the nozzle is identical to the velocity in the nozzle, but the contact with the atmosphere makes the pressure atmospheric.

For the case when frictional losses may be neglected, the mechanical energy balance reduces to

$$\frac{P_2 - P_1}{\rho} + \frac{u_2^2 - u_1^2}{2} = 0 \quad (\text{E19.3a})$$



Figure E19.3 Illustration of Nozzle for Example 19.3

which yields

$$\frac{(14.7 - 50) \text{ lb}_f/\text{in}^2 (12 \text{ in}/\text{ft})^2}{62.4 \text{ lb}/\text{ft}^3} + \frac{u_2^2 - \left[\frac{4(2 \text{ gal}/\text{min})(\text{ft}^3/7.48 \text{ gal})(\text{min}/60 \text{ sec})}{\pi(1/12 \text{ ft})^2} \right]^2}{2(32.2 \text{ ft}/\text{lb}_f/\text{sec}^2)} = 0 \quad (\text{E19.3b})$$

so $u_2 = 72.4 \text{ ft}/\text{sec}$. For a real system, there would be some frictional losses and the actual discharge velocity would be lower than calculated here.

This problem was solved under the assumption of turbulent flow. The criterion for turbulent flow is introduced later; however, for this system, the Reynolds number is about 2×10^5 , which is well into the turbulent flow region.

19.1.3 Force Balance

The force balance is essentially a statement of Newton's law. A common form for flow in pipes is

$$\Delta(\dot{m}\underline{u}) = \sum \underline{F} \quad (19.12)$$

where F are the forces on the system. The underlined parameters indicate vectors, since there are three spatial components of a force balance. For steady-state flow and the typical forces involved in fluid flow, Equation (19.12) reduces to

$$\dot{m}\Delta(\underline{u}) = \underline{F}_p + \underline{F}_d + \underline{F}_g + \underline{R} \quad (19.13)$$

where \underline{F}_p is the pressure force on the system, \underline{F}_d is the drag force on the system, \underline{F}_g is the gravitational force on the system, and \underline{R} is the restoring force on the system, that is, the force necessary to keep the system stationary. The term on the left side of Equation (19.12) is acceleration, confirming that Equation (19.12) is a statement of Newton's law. The most common application of Equation (19.13) is to determine the restoring forces on an elbow. These problems are not discussed here.

19.2 FLUID FLOW EQUIPMENT

The basic characteristics of fluid flow equipment are introduced in this section. The performance of pumps and compressors is dictated by their characteristic curves and, for pumps, the net positive suction head curve. The performance of these pieces of equipment is discussed in Section 19.5.

19.2.1 Pipes

Pipes and their associated fittings that are used to transport fluid through a chemical plant are usually made of metal. For noncorrosive fluids under conditions that are not of special concern, carbon steel is typical. For more extreme conditions, such as higher pressure, higher temperature, or corrosive fluids, stainless steel or other alloy steels may be needed. It may even be necessary, for very-high-temperature service such as for the flow of molten metals, to use refractory-lined pipes.

Pipes are sized using a nominal diameter and a schedule number. The higher the schedule number, the thicker the pipe walls, making pipes with a higher schedule number more suitable for higher-pressure operations. The nominal diameter is a number such as 2 in; however, there is no dimension of the pipe that is actually 2 in until the diameter reaches 14 in. For pipes with

a diameter of 14 in or larger, the nominal diameter is the outside diameter. Pipes typically have integer nominal diameters; however, for smaller diameters, they can be in increments of 0.25 in. At larger diameters, the nominal diameters may only be even integer values. Table 19.1 shows the dimensions of some schedules of standard pipe.

Table 19.1 Dimensions of Standard Steel Pipe

Nominal Size (in)	Outside Diameter		Schedule Number	Wall Thickness		Inside Diameter		Inside Cross-Sectional Area	
	in	mm		in	mm	in	mm	10 ² ft ²	10 ⁴ m ²
1/8	0.405	10.29	40	0.068	1.73	0.269	6.83	0.040	0.3664
			80	0.095	2.41	0.215	5.46	0.025	0.2341
1/4	0.540	13.72	40	0.088	2.24	0.364	9.25	0.072	0.6720
			80	0.119	3.02	0.302	7.67	0.050	0.4620
3/8	0.675	17.15	40	0.091	2.31	0.493	12.52	0.133	1.231
			80	0.126	3.20	0.423	10.74	0.098	0.9059
1/2	0.840	21.34	40	0.109	2.77	0.622	15.80	0.211	1.961
			80	0.147	3.73	0.546	13.87	0.163	1.511
3/4	1.050	26.67	40	0.113	2.87	0.824	20.93	0.371	3.441
			80	0.154	3.91	0.742	18.85	0.300	2.791
1	1.315	33.40	40	0.133	3.38	1.049	26.64	0.600	5.574
			80	0.179	4.45	0.957	24.31	0.499	4.641
1 1/4	1.660	42.16	40	0.140	3.56	1.380	35.05	1.040	9.648
			80	0.191	4.85	1.278	32.46	0.891	8.275
1 1/2	1.900	48.26	40	0.145	3.68	1.610	40.89	1.414	13.13
			80	0.200	5.08	1.500	38.10	1.225	11.40
2	2.375	60.33	40	0.154	3.91	2.067	52.50	2.330	21.65
			80	0.218	5.54	1.939	49.25	2.050	19.05
2 1/2	2.875	73.03	40	0.203	5.16	2.469	62.71	3.322	30.89
			80	0.276	7.01	2.323	59.00	2.942	27.30
3	3.500	88.90	40	0.216	5.59	3.068	77.92	5.130	47.69
			80	0.300	7.62	2.900	73.66	4.587	42.61
3 1/2	4.000	101.6	40	0.226	5.74	3.548	90.12	6.870	63.79
			80	0.318	8.08	3.364	85.45	6.170	57.35
4	4.500	114.3	40	0.237	6.02	4.026	102.3	8.840	82.19
			80	0.337	8.56	3.826	97.18	7.986	74.17
5	5.563	141.3	40	0.258	6.55	5.047	128.2	13.90	129.1
			80	0.375	9.53	4.813	122.3	12.63	117.5
6	6.625	168.3	40	0.280	7.11	6.065	154.1	20.06	186.5
			80	0.432	10.97	5.761	146.3	18.10	168.1

Nominal Size (in)	Outside Diameter		Schedule Number	Wall Thickness		Inside Diameter		Inside Cross-Sectional Area	
	in	mm		in	mm	in	mm	10 ² ft ²	10 ⁴ m ²
8	8.625	219.1	40	0.322	8.18	7.981	202.7	34.74	322.7
			80	0.500	12.70	7.625	193.7	31.71	294.7
10	10.75	273.1	40	0.365	9.27	10.02	254.5	54.75	508.6
			80	0.594	15.09	9.562	242.8	49.87	463.3
12	12.75	304.8	40	0.406	10.31	11.94	303.3	77.73	722.1
			80	0.688	17.48	11.37	288.8	70.56	655.5
14	14	355.6	40	0.438	11.13	13.12	333.2	93.97	873.0
			80	0.750	19.05	12.50	317.5	85.22	791.7
16	16	406.4	40	0.500	12.70	15.00	381.0	122.7	1140
			80	0.844	21.44	14.31	363.5	111.7	1038
18	18	457.2	40	0.562	14.27	16.88	428.8	155.3	1443
			80	0.938	23.83	16.12	409.4	141.8	1317
20	20	508.0	40	0.597	15.16	18.81	477.8	193.0	1793
			80	1.031	26.19	17.94	455.7	175.5	1630
24	24	635.0	40	0.688	17.48	22.62	574.5	279.2	2594
			80	1.219	30.96	21.56	547.6	253.6	2356

Source: Adapted from Geankoplis, C., *Transport Processes and Separation Process Principles*, 4th ed., Prentice Hall, Upper Saddle River, 2003 [1]; Perry, R. H., and D. Green, *Perry's Chemical Engineers' Handbook*, 6th ed., McGraw-Hill, New York, 1984, Section 5 [2].

Tubing is commonly used in heat exchangers. The dimensions and use of tubing are discussed in Chapter 20.

Pipes are typically connected by screw threads, flanges, or welds. Welds and flanges are more suitable for larger diameters and higher-pressure operation. Proper welds are stronger and do not leak, whereas screwed or flanged connections can leak, especially at higher pressures. Changes in direction are usually accomplished by elbows or tees, and those changes in direction are usually 90°.

19.2.2 Valves

Valves are found in piping systems. Valves are about the only way to regulate anything in a chemical process. Valves serve several functions. They are used to regulate flowrate, reduce pressure by adding resistance, or isolate (turn flow on/off) equipment.

Two common types of valves are gate valves and globe valves. Figure 19.3 shows illustrations of several common types of valves.

Gate valves are used for on/off control of fluid flow. The flow path through a gate valve is roughly straight, so when the valve is fully open, the pressure drop is very small. However, gate valves are not suitable for flowrate regulation because the flowrate does not change much until the “gate” is almost closed. There are also ball valves, in which a quarter turn opens a flow channel, and they can also be used for on/off regulation.

Globe valves are more suitable than gate valves for flowrate and pressure regulation. Because the flow path is not straight, globe valves have a higher pressure drop even when wide open. Globe valves are well suited for flowrate regulation because the flowrate is responsive to valve position. In a control system, the valve stem is raised or lowered pneumatically (by instrument air) or via

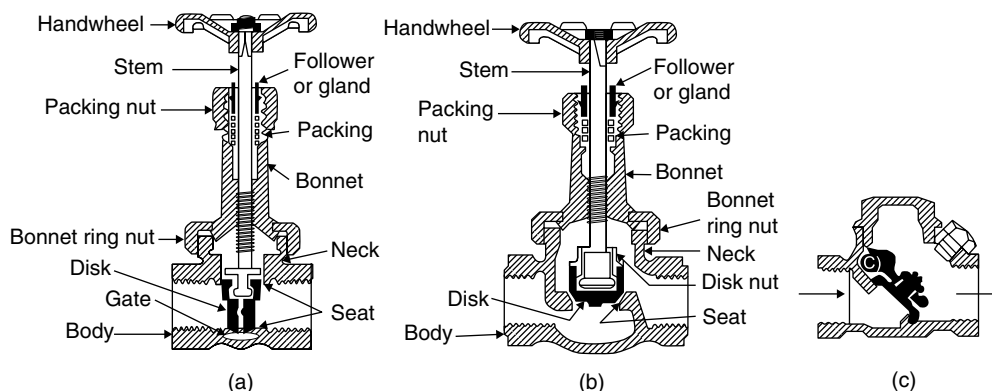

Figure 19.3 Common Types of Valves: (a) Gate, (b) Globe, (c) Swing Check (Reproduced by Permission from Couper, J. R. et al. *Chemical Process Equipment: Selection and Design*, 3rd ed. [New York, Elsevier, 2012] [3])

an electric motor in response to a measured parameter, such as a flowrate. Pneumatic systems can be designed for the valve to fail open or closed, the choice depending on the service. Failure is defined as loss of instrument air pressure. For example, for a valve controlling the flowrate of a fluid removing heat from a reactor with a highly exothermic reaction, the valve would be designed to fail open so that the reactor cooling is not lost.

Check valves, such as the swing check valve, are used to ensure unidirectional flow. In Figure 19.3(c), if the flow is left to right, the swing is opened and flow proceeds. If the flow is right to left, the swing closes, and there is no flow in that direction. Such valves are often placed on the discharge side of pumps to ensure that there is no flow reversal through the pump.

19.2.3 Pumps

Pumps are used to transport liquids, and pumps can be damaged by the presence of vapor, a phenomenon discussed in Section 19.5.2. The two major classifications for pumps are *positive displacement* and *centrifugal*. For a more detailed summary of all types of pumps, see Couper et al. [3] or Green and Perry [4].

Positive-displacement pumps are often called **constant-volume pumps** because a fixed amount of liquid is taken into a chamber at a low pressure and pushed out of the chamber at a high pressure. The chamber has a fixed volume, hence the name. An example of a positive-displacement pump is a reciprocating pump, illustrated in Figure 19.4(a). Specifically, this is an example of a piston pump in which the piston moves in one direction to pull liquid into the chamber and then moves in the opposite direction to discharge liquid out of the chamber at a higher pressure. There are other variations of positive-displacement pumps, such as rotary pumps in which the chamber moves between the inlet and discharge points. In general, positive-displacement pumps can increase pressure more than centrifugal pumps and run at higher pressures overall. These characteristics define their applicability. Efficiencies tend to be between 50% and 80%. Positive-displacement pumps are preferred for higher pressures, higher viscosities, and anticipated viscosity variations.

In centrifugal pumps, which are a common workhorse in the chemical industry, the pressure is increased by the centrifugal action of an impeller. An impeller is a rotating shaft with blades, and it might be tempting to call it a propeller because an impeller resembles a propeller. (While there might be a resemblance, the term **propeller** is reserved for rotating shafts with blades that move an object, such as a boat or airplane.) The blades of an impeller have small openings, known as

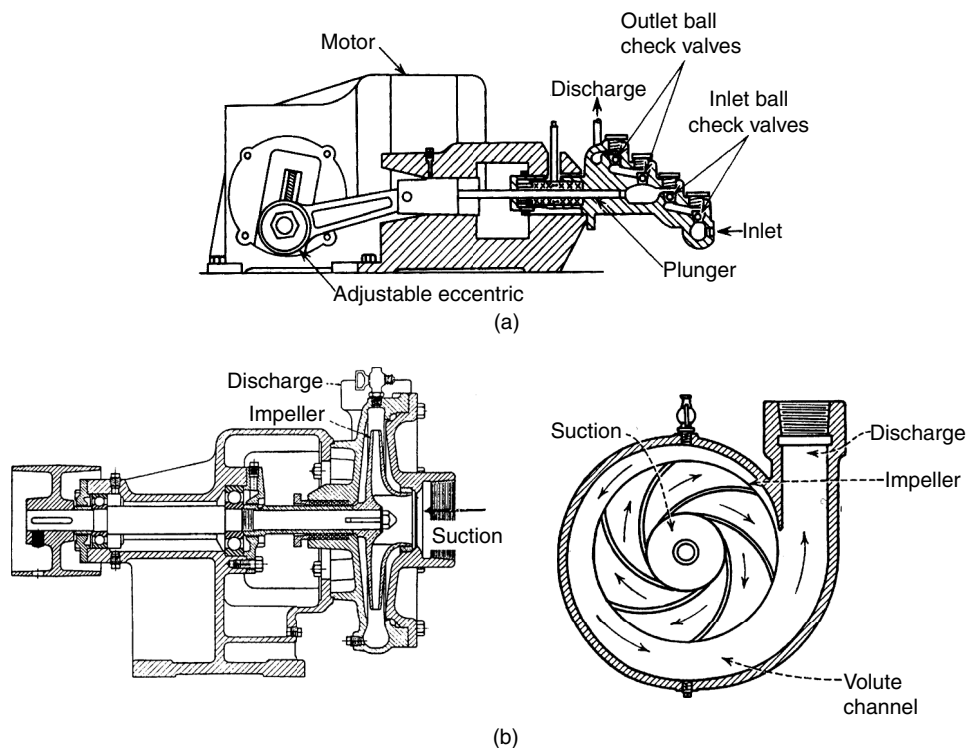

Figure 19.4 (a) Inner Workings of Positive-Displacement Pump, (b) Inner Workings of Centrifugal Pump ([a] Reproduced by Permission from McCabe, W. L. et al., *Unit Operations of Chemical Engineering*, 5th ed. [New York, McGraw-Hill, 1993] [5]; [b] Reproduced by Permission from Couper, J. R. et al., *Chemical Process Equipment: Selection and Design*, 3rd ed. [New York, Elsevier, 2012] [3])

vanes, that increase the kinetic energy of the liquid. The liquid is then discharged through a **volute** in which the kinetic energy is converted into pressure. Figure 19.4(b) shows a centrifugal pump. Centrifugal pumps often come with impellers of different diameters, which enable pumps to be used for different services (different pressure increases). Of course, shutdown is required to change the impeller. Although standard centrifugal pump impellers only spin at a constant rate, variable-speed centrifugal pumps also are available.

Centrifugal pumps can handle a wide range of capacities and pressures, and depending on the exact type of pump, the efficiencies can range from 20% to 90%.

19.2.4 Compressors

Devices that increase the pressure of gases fall into three categories: fans, blowers, and compressors. Figure 19.5 illustrates some of this equipment. For a more detailed summary of all types of pumps, see Couper et al. [3] or Green and Perry [4].

Fans provide very low-pressure increases (<1 psi [7 kPa]) for low volumes and are typically used to move air. Blowers are essentially mini-compressors, providing a maximum pressure of about 30 psi (200 kPa). Blowers can be either positive displacement or centrifugal, and while their general construction is similar to pumps, there are many internal differences. Compressors, which can also be either positive displacement or centrifugal, can provide outlet pressures of 1500 psi (10 MPa) and sometimes even 10 times that much.

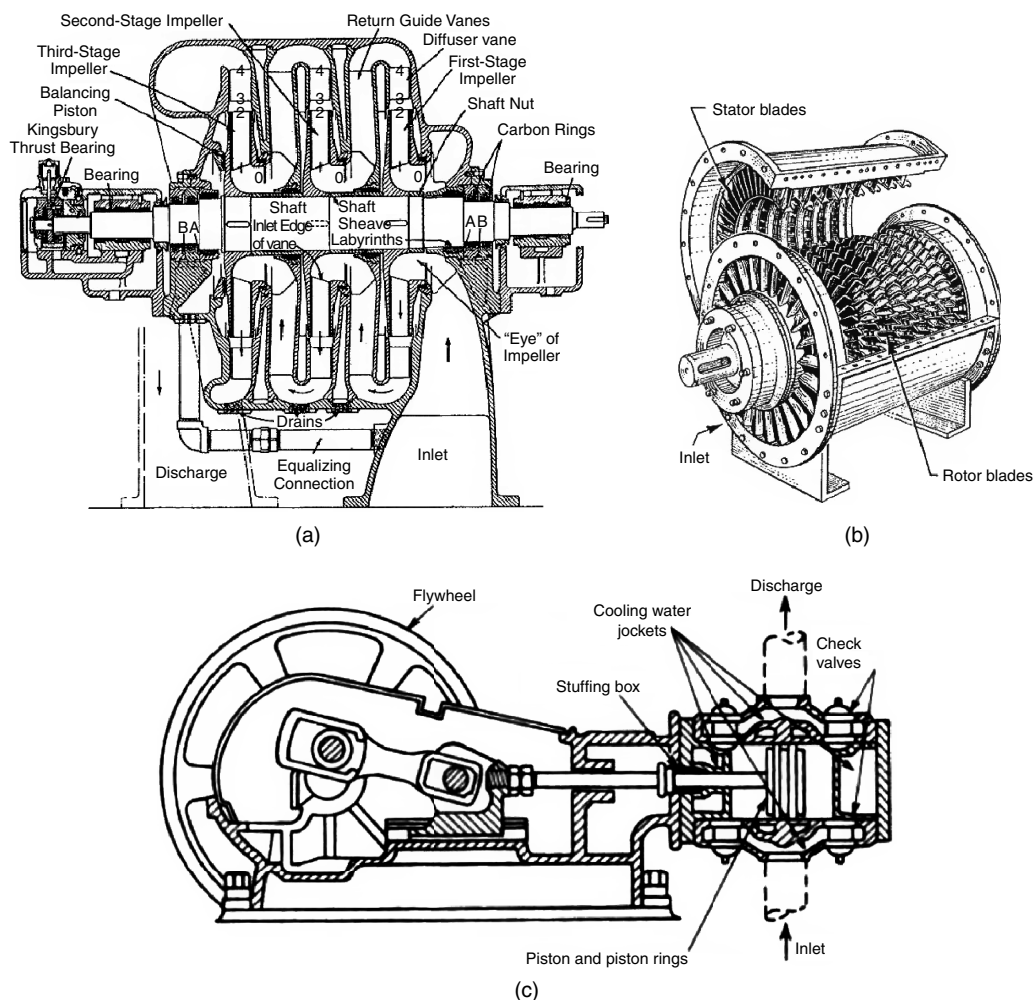

Figure 19.5 Inner Working of Compressors: (a) Centrifugal, (b) Axial, (c) Positive Displacement ([a] and [b] Reproduced by Permission from Couper, J. R. et al., *Chemical Process Equipment: Selection and Design*, 3rd ed. [New York: Elsevier, 2012]; [c] Reproduced by Permission from McCabe, W. L. et al., *Unit Operations of Chemical Engineering*, 5th ed. [New York: McGraw-Hill, 1993])

In a centrifugal compressor, the impeller may spin at tens of thousands of revolutions per minute. If liquid droplets or solid particles are present in the gas, they hit the impeller blades at such high relative velocity that the impeller blades will erode rapidly and may cause bearings to become damaged, leading to mechanical failure. The compressor casing also may crack. Therefore, it is important to ensure that the gas in a centrifugal compressor does not contain solids and liquids. A filter can be used to keep particles out of a compressor, and a packed-bed adsorbent can also be used, for example, to remove water vapor from inlet air. Knockout drums are often provided between compressor stages with intercooling to allow the disengagement of any condensed drops of liquid and are covered in more detail in Chapter 23, Section 23.2. The seals on compressors are temperature sensitive, so a maximum temperature in one stage of a compressor is generally not exceeded, which is another reason for staged, intercooled compressor systems. It should also be noted that compressors are often large and expensive pieces of equipment that often have a large number of auxiliary systems associated with them. The coverage given in this text is very simplified but allows the estimate of the power required.

Positive-displacement compressors typically handle lower flowrates but can produce higher pressures compared to centrifugal compressors. Efficiencies for both types of compressor tend to be high, above 75%.

19.3 FRICTIONAL PIPE FLOW

19.3.1 Calculating Frictional Losses

The fourth term in Equation (19.5) must be evaluated to include friction in the mechanical energy balance. There are different expressions for this term depending on the type of flow and the system involved. In general, the friction term is

$$e_f = \frac{2fLu^2}{D} = \frac{32fL\dot{v}^2}{\pi^2 D^5} \quad (19.14)$$

where L is the pipe length, D is the pipe diameter, and f is the Fanning friction factor. (The Fanning friction factor is typically used by chemical engineers. There is also the Moody friction factor, which is four times the Fanning friction factor. Care must be used when obtaining friction factor values from different sources. It is even more confusing, since the plot of friction factor versus Reynolds number is called a *Moody plot* for both friction factors.) The friction factor is a function of the Reynolds number ($Re = Du\rho/\mu$, where μ is the fluid viscosity), and its form depends on the flow regime (laminar or turbulent), and for turbulent flow, f is also a function of the pipe roughness factor (e , a length that represents small asperities on the pipe wall; values are given at the top of Figure 19.6), which is a tabulated value.

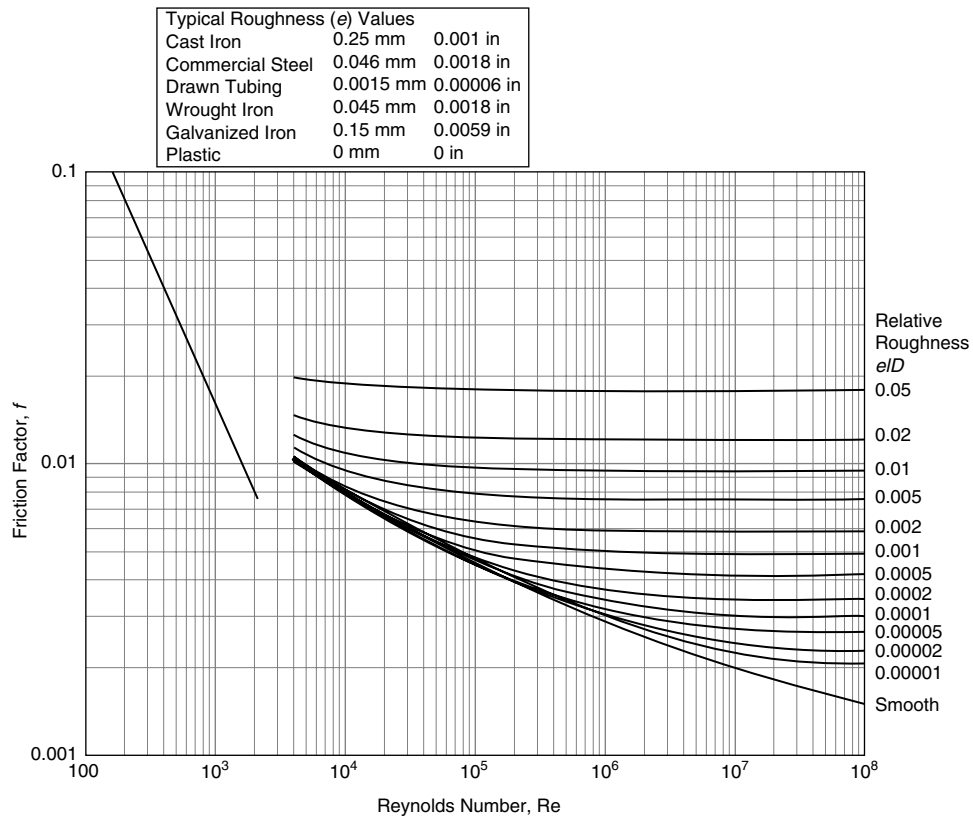

Figure 19.6 Moody Plot for the Fanning Friction Factor in Pipes

Historically, the friction factor was measured and the data were plotted in graphical form. Figure 19.6 is such a plot. A key observation from Figure 19.6 is that, with the exception of smooth pipes, the friction factor asymptotically approaches a constant value above a Reynolds number of approximately 10^5 . This is called fully developed turbulent flow, and the friction factor becomes constant and can be used to simplify certain calculations, examples of which are presented later. Typical values for the pipe roughness for some common materials are shown at the top of Figure 19.6.

The friction factor for laminar flow is a theoretical result derivable from the Hagen-Poiseuille equation [6] and is valid for $Re < 2100$.

$$f = \frac{16}{Re} = \frac{16\mu}{Du\rho} \quad (19.15)$$

For turbulent flow, the data have been fit to equations. One such equation is the Pavlov equation ([7] [cited in Levenspiel [8]]):

$$\frac{1}{f^{0.5}} = -4 \log_{10} \left[\frac{e}{3.7D} + \left(\frac{6.81}{Re} \right)^{0.9} \right] \quad (19.16)$$

The Pavlov equation provides results within a few percent of the measured data. There are more accurate equations; however, they are not explicit in the friction factor. Any of these curve fits provides significantly more accuracy than reading a graph.

For flow in pipes containing valves, elbows, and other pipe fittings, there are two common methods for including the additional frictional losses created by this equipment. One is the **equivalent length** method, whereby additional pipe length is added to the value of L in Equation (19.14). The other method is the **velocity head** method, in which a value (K_i) is assigned to each valve, fitting, and so on, and an additional frictional loss term is added to the frictional loss term in Equation (19.14). These terms are of the form

$$\sum_i \frac{K_i u_i^2}{2} \quad (19.17)$$

where the index i indicates a sum over all valves, elbows, and similar components in the system. If there are different pipe diameters within the system, the velocity in Equation (19.17) is specific to each section of pipe, and a term for each section of pipe must be included. It should be noted that the equivalent K_i value for straight pipe (K_{pipe}) is given by

$$K_{pipe} = \frac{4fL}{D} \quad (19.18)$$

Tables 19.2 and 19.3 show equivalent lengths and K_i values for some common items found in pipe networks, for turbulent flow and for laminar flow, respectively. The values are different for laminar and turbulent flow. Darby [9] presents analytical expressions for the K values that can be used for more exact calculations.

Another common situation involves frictional loss in a packed bed, that is, a vessel packed with solids. One application is if the solids are catalysts, making the packed bed a reactor. The frictional loss term for packed beds is obtained from the Ergun equation, which yields a friction term for a packed bed as

$$e_f = \frac{Lu_s^2(1-\varepsilon)}{\varepsilon^3 D_p} \left[\frac{150(1-\varepsilon)\mu}{D_p u_s \rho} + 1.75 \right] \quad (19.19)$$

where u_s is the superficial velocity (based on pipe diameter, not particle diameter), D_p is the particle diameter (assumed spherical here; corrections are available for nonspherical shape), and ε is the packing void fraction, which is the volume fraction in the packed bed not occupied by solids.

Table 19.2 Frictional Losses for Turbulent Flow

Type of Fitting or Valve	Frictional Loss, Number of Velocity Heads, K_f	Frictional Loss, Equivalent Length of Straight Pipe, in Pipe Diameters, L_{eq}/D
45° elbow	0.35	17
90° elbow	0.75	35
Tee	1	50
Return bend	1.5	75
Coupling	0.04	2
Union	0.04	2
Gate valve, wide open	0.17	9
Gate valve, half open	4.5	225
Globe valve, wide open	6.0	300
Globe valve, half open	9.5	475
Angle valve, wide open	2.0	100
Check valve, ball	70.0	3500
Check valve, swing	2.0	100
Contraction	$0.55(1 - A_2/A_1)$	$27.5(1 - A_2/A_1)$
Contraction $A_2 \ll A_1$	0.55	27.5
Expansion	$(1 - A_1/A_2)^2$	$50(1 - A_1/A_2)^2$
Expansion $A_1 \ll A_2$	1	50

Source: From Geankoplis, C., *Transport Processes and Separation Process Principles*, 4th ed., (Upper Saddle River, NJ: Prentice Hall, 2003); Perry, R. H., and D. Green, *Perry's Chemical Engineers' Handbook*, 6th ed. (New York: McGraw-Hill, 1984), Section 5.

Table 19.3 Frictional Loss for Laminar Flow

Reynolds number	Frictional Loss, Number of Velocity Heads, K_f					
	50	100	200	400	1000	Turbulent
90° elbow	17	7	2.5	1.2	0.85	0.75
Tee	9	4.8	3.0	2.0	1.4	1.0
Globe valve	28	22	17	14	10	6.0
Check valve, swing	55	17	9	5.8	3.2	2.0

Source: From Geankoplis, C., *Transport Processes and Separation Process Principles*, 4th ed. (Upper Saddle River, NJ: Prentice Hall, 2003), 99–100, citing Kittredge, C. P., and D. S. Rowley, "Resistance Coefficients for Laminar and Turbulent Flow Through One-Half-Inch Valves and Fittings," *Trans. ASME*, 79 (1957): 1759–1766.

When Equation (19.19) is used in the mechanical energy balance, one unknown parameter, such as velocity, pressure drop, or particle diameter, can be obtained.

For incompressible flow in packed beds, the Ergun equation, Equation (19.19), is used for the friction term in the mechanical energy balance.

For the expansion and contraction losses, A_1 is the cross-sectional area of the pipe, subscript 1 is the upstream area, and subscript 2 is the downstream area.

19.3.2 Incompressible Flow

19.3.2.1 Single-Pipe Systems

Incompressible flow problems fall into three categories:

1. Any parameter unknown in the mechanical energy balance other than velocity (flowrate) or diameter
2. Unknown velocity (flowrate)
3. Unknown diameter

For turbulent flow problems with any unknown other than velocity (or flowrate) or diameter, in the mechanical energy balance, Equation (19.5), there is a second unknown: the friction factor. The friction factor can be calculated from Equation (19.15). The solution method can use a sequential calculation, solving Equation (19.5) for the unknown once the friction factor is calculated. If there are valves, elbows, and so on, the length term in Equation (19.15) can be adjusted appropriately or Equation (19.17) can be used. Alternatively, Equations (19.14) and (19.16) can be solved simultaneously to yield all the unknowns. Example 19.5 shows both of these calculation methods. For laminar flow problems, Equation (19.15) can be combined with Equation (19.14) in the mechanical energy balance to solve any problem analytically.

For turbulent flow, if the velocity is unknown, Equations (19.5) and (19.15) must be solved simultaneously for the velocity or flowrate and the friction factor. When solving for a velocity directly, if the pump work term must be included, it is necessary to express the mass flowrate in terms of velocity. If solving for the volumetric flowrate, the second equality in Equation (19.13) must be used, and if a kinetic energy term is required in the mechanical energy balance, the velocities must be expressed in terms of volumetric flowrate. In the friction factor equation, the Reynolds number also needs to be expressed in terms of the volumetric flowrate as follows:

$$\text{Re} = \frac{D u \rho}{\mu} = \frac{D \rho}{\mu} \frac{\dot{v}}{A} = \frac{D \rho}{\mu} \frac{4 \dot{v}}{\pi D^2} = \frac{4 \dot{v} \rho}{\pi D \mu} \quad (19.20)$$

For laminar flow, an analytical solution is possible simply by using Equation (19.14) for the friction factor in the mechanical energy balance.

For turbulent flow, if the diameter is unknown, Equations (19.5) and (19.13) (second equality involving flowrate and diameter to the fifth power) must be solved simultaneously, using Equation (19.20) for the Reynolds number. For laminar flow, an analytical solution may once again be possible by using Equation (19.12) for the friction factor in the mechanical energy balance. If kinetic energy terms are involved, an unknown diameter will appear when expressing velocity in terms of flowrate. If minor losses are involved, the equivalent length will include a diameter term, and the K-value method will include a diameter in the conversion between flowrate and velocity.

Examples 19.4 and 19.5 illustrate the methods for solving these types of problems.

Example 19.4

Consider a physical situation similar to that in Example 19.2. The flowrate between tanks is 10 lb/sec. The source-tank level is 10 ft off of the ground, and the discharge-tank level is 50 ft off of the ground. For this example, both tanks are open to the atmosphere. The suction-side pipe is 2-in. schedule-40, commercial steel, and the discharge-side pipe is 1.5-in. schedule-40, commercial steel. The length of the suction line is 25 ft, and the length of the discharge line is 60 ft. The pump efficiency is 75%. Losses due to fittings, expansions, and contractions may be assumed negligible for this problem.

- Determine the required horsepower of the pump.
- Determine the pressures before and after the pump.

Solution

- The physical situation is depicted in Figure E19.4.

For the control volume of the fluid in both tanks, the pipes, and the pump, the mechanical energy balance reduces to

$$g\Delta z + e_{f,\text{suct}} + e_{f,\text{disch}} - \frac{\eta_p \dot{W}_s}{\dot{m}} = 0 \quad (\text{E19.4a})$$

The pressure term is zero, because both tanks are open to the atmosphere ($P_1 = P_2 = 1 \text{ atm}$). The kinetic energy term is zero, because the velocities of the fluid at the surfaces of both tanks are assumed to be zero. There are two friction terms, one for the suction side of the pump and one for the discharge side of the pump, because the friction factors are different due to the different pipe diameters.

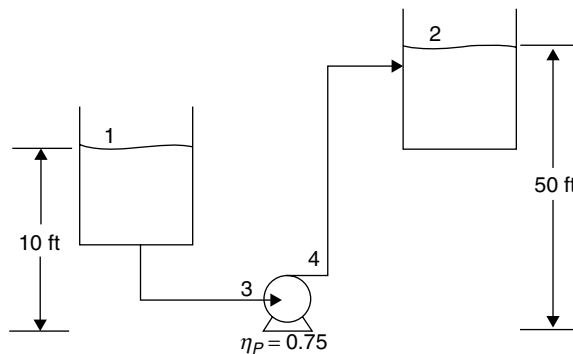

Figure E19.4

To calculate the friction terms, the Reynolds numbers must be calculated first for each section to determine whether the flow is laminar or turbulent. Since a temperature is not provided, the density is assumed to be 62.4 lb/ft^3 , and the viscosity is assumed to be $1 \text{ cP} = 6.72 \times 10^{-4} \text{ lb/ft}\cdot\text{sec}$. Using Table 19.1 for the schedule pipe diameter and cross-sectional area, the Reynolds number for the suction side is

$$\text{Re} = \frac{D u \rho}{\mu} = \frac{(2.067/12 \text{ ft}) \left(\frac{10 \text{ lb/sec}}{(0.0233 \text{ ft}^2)(62.4 \text{ lb/ft}^3)} \right) (62.4 \text{ lb/ft}^3)}{6.72 \times 10^{-4} \text{ lb/ft}\cdot\text{sec}} = 110,000 \quad (\text{E19.4b})$$

Similarly, the Reynolds number for the discharge side is 141,200. Therefore, the flow is turbulent in both sections of pipe. The friction factor is now calculated for each section of pipe. For the suction side, with commercial-steel pipe ($e = 0.0018 \text{ in}$ from the top of Figure 19.6),

$$\frac{1}{f^{0.5}} = -4 \log_{10} \left[\frac{0.0018 \text{ in}}{3.7(2.067 \text{ in})} + \left(\frac{6.81}{110,010} \right)^{0.9} \right] \quad (\text{E19.4c})$$

so $f_{\text{suct}} = 0.0054$. Similarly, $f_{\text{disch}} = 0.0055$. Now, the mechanical energy balance on the entire system is used to solve for the pump power:

$$\begin{aligned} & \frac{(32.2 \text{ ft/sec}^2)(40 \text{ ft})}{32.2 \text{ ft lb/lb}_f/\text{sec}^2} + \frac{2(0.0054)(25 \text{ ft}) \left(\frac{10 \text{ lb/sec}}{(0.0233 \text{ ft}^2)(62.4 \text{ lb/ft}^3)} \right)^2}{\left(\frac{2.067}{12} \text{ ft} \right) (32.2 \text{ ft lb/lb}_f/\text{sec}^2)} \\ & + \frac{2(0.0055)(60 \text{ ft}) \left(\frac{10 \text{ lb/sec}}{(0.01414 \text{ ft}^2)(62.4 \text{ lb/ft}^3)} \right)^2}{\left(\frac{1.61}{12} \text{ ft} \right) (32.2 \text{ ft lb/lb}_f/\text{sec}^2)} - \frac{(0.75)\dot{W}_s (550 \text{ ft lb}_f/\text{sec}/\text{hp})}{(10 \text{ lb/sec})} = 0 \end{aligned} \quad (\text{E19.4d})$$

Solving Equation (E19.4d) gives $\dot{W}_s = 1.5$ hp. If the contribution of each term is enumerated, 0.97 hp is to overcome the potential energy and 0.48 hp is to overcome the discharge line friction, with 0.056 hp to overcome the suction line friction. Generally, potential energy differences and pressure differences are more significant than frictional losses.

- b. To obtain the pressure on the suction side of the pump, the mechanical energy balance is written on the control volume of the fluid in the tank and pipes before the pump.

$$\frac{P_3 - P_1}{\rho} + \frac{u_3^2}{2} + g\Delta z + e_f = 0 \quad (\text{E19.4e})$$

$$\begin{aligned} & \frac{[P_3 - (14.7)](144) \text{ lb}_f/\text{ft}^2}{62.4 \text{ lb/ft}^3} + \frac{\left(\frac{10 \text{ lb/sec}}{(0.0233 \text{ ft}^2)(62.4 \text{ lb/ft}^3)} \right)^2}{2(32.2 \text{ ft lb/lb}_f/\text{sec}^2)} + \frac{(32.2 \text{ ft/sec}^2)(-10 \text{ ft})}{32.2 \text{ ft lb/lb}_f/\text{sec}^2} \\ & + \frac{2(0.0054)(15 \text{ ft}) \left(\frac{10 \text{ lb/sec}}{(0.0233 \text{ ft}^2)(62.4 \text{ lb/ft}^3)} \right)^2}{\left(\frac{2.067}{12} \text{ ft} \right) (32.2 \text{ ft lb/lb}_f/\text{sec}^2)} = 0 \end{aligned} \quad (\text{E19.4f})$$

So, $P_3 = 17.7$ psi. It is observed that the height change in the potential energy term is negative, since the point at the pump entrance is below the liquid level in the tank, noting that the z -coordinate system is positive in the upward direction.

There are two ways to obtain the discharge-side pressure. One is to solve the mechanical energy balance on the control volume between Points 4 and 2. The other method is to write the mechanical energy balance on the fluid in the pump (pressure, kinetic energy, and work terms) to obtain the pressure rise in the pump. Both methods give the same result of $P_4 = 28.9$ psi.

The discharge line of a pump is at a slightly higher elevation than the suction line, as illustrated. This height difference is small and is neglected in this analysis.

Example 19.5

Determine the required horsepower of the pump in Example 19.4 if the presence of one 90° elbow and one wide-open gate valve in the suction line and one wide-open gate valve, one half-open globe valve, and two 90° elbows in the discharge line are included.

Solution

The solution to this problem starts with Equation (E19.4d). Friction terms must be added for each item in each section of pipe. Using the equivalent length method for the suction line, $L_{eq} = 25 \text{ ft} + (2.067/12 \text{ ft})$

$(35 + 9 + 27.5) = 37.3$ ft, where the equivalent length terms for the elbow, gate valve, and contraction upon leaving the source tank, respectively, are obtained from Table 19.2. For the discharge line, $L_q = 60$ ft + $(1.61/12$ ft) $[2(35) + 9 + 475 + 50] = 141.04$ ft, where the equivalent length terms are for the two elbows, gate valve, globe valve, and expansion upon entering the destination tank, respectively. In terms of friction, these items add significantly to the frictional losses, especially the half-open globe valve in the discharge line. The result is that $\dot{W}_s = 2.71$ hp.

It is also possible to use the velocity heads method. For the suction side, once again referring to Table 19.2, $\sum K_i = 0.75 + 0.17 + 0.55 = 1.47$, so a term of $1.47u_1^2/2/32.2$ is added to the mechanical energy balance. For the discharge side, $K = 2(0.75) + 0.17 + 9.5 + 1 = 12.17$, so a term of $12.17u_2^2/2/32.2$ is added to the mechanical energy balance. The result is 2.12 hp, which illustrates that the two methods do not give exactly the same results. The difference is because both methods are empirical and are subject to uncertainties. Either method is within the typical tolerance of a design specification. To provide flexibility and since pumps are typically available at fixed values, at least a 3 hp pump would probably be used here, and valves would be used to adjust the flowrate to the desired value.

Example 19.6

A fuel oil ($\mu = 70 \times 10^{-3}$ kg/m/s, SG = 0.9) is pumped through 2.5-in, schedule-40 pipe for 500 m at 3 kg/s. The discharge point is 5 m above the inlet, and the source and destination are both at 101 kPa. If the pump is 80% efficient, what power is required?

Solution

The situation is shown in Figure E19.6.

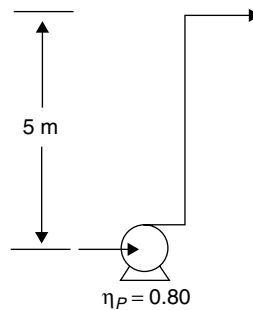

Figure E19.6

The control volume is the fluid in the pipe between the source and destination. The mechanical energy balance contains only the potential energy, friction, and work terms, since there is only one pipe (velocity constant) and since the pressures are identical at the source and destination. The mechanical energy balance is

$$g\Delta z + e_f - \frac{\eta_p \dot{W}_s}{\dot{m}} = 0 \quad (\text{E19.6a})$$

As in Example 19.4, the Reynolds number should be calculated first:

$$\text{Re} = \frac{D u \rho}{\mu} = \frac{(0.06271 \text{ m}) \left(\frac{3 \text{ kg/s}}{(0.003089 \text{ m}^2)(900 \text{ kg/m}^3)} \right) (900 \text{ kg/m}^3)}{70 \times 10^{-3} \text{ kg/m/s}} = 870 \quad (\text{E19.6b})$$

Therefore, the flow is laminar, and the friction factor $f = 16/\text{Re}$. A hint that the flow might be laminar is that the fluid is 70 times more viscous than water. This emphasizes the need to check the Reynolds number before proceeding.

The mechanical energy balance is then

$$(9.8 \text{ m/s}^2)(5 \text{ m}) + \frac{2\left(\frac{16}{870}\right)(500 \text{ m})\left(\frac{3 \text{ kg/s}}{(0.003089 \text{ m}^2)(900 \text{ kg/m}^3)}\right)^2}{0.06271 \text{ m}} - \frac{0.8\dot{W}_s}{3 \text{ kg/s}} = 0 \quad (\text{E19.6c})$$

which gives $\dot{W}_s = 1464 \text{ W}$.

Example 19.7

Water flows from a constant-level tank at atmospheric pressure through 8 m of 1-in, schedule-40, commercial-steel pipe. It discharges to atmosphere 4 m below the level in the source tank. Calculate the mass and volumetric flowrates, neglecting entrance and exit losses.

Solution

Since the flowrate is unknown, the velocity is unknown, so the Reynolds number cannot be calculated, which means that the friction factor cannot be calculated initially. A simultaneous solution of the friction factor equation and the mechanical energy balance is necessary. Since the fluid is water, turbulent flow will be assumed, but it must be checked once the velocity or flowrate has been calculated.

The control volume is the fluid in the tank and the discharge pipe. In Figure E19.7, Point 1 is the level in the tank, which is at zero velocity, and Point 2 is the pipe discharge to the atmosphere.

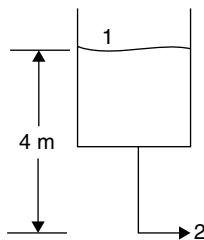

Figure E19.7

The mechanical energy balance reduces to

$$\frac{u_2^2}{2} + g\Delta z + \frac{2fu_2^2}{D} = 0 = \frac{u_2^2}{2} = (9.8 \text{ m/s}^2)(-4 \text{ m}) + \frac{2f(8 \text{ m})u_2^2}{0.02664 \text{ m}} \quad (\text{E19.7a})$$

and the friction factor is

$$\frac{1}{f^{0.5}} = -4 \log_{10} \left[\frac{4.6 \times 10^{-5} \text{ m}}{3.7(0.02664 \text{ m})} + \left(\frac{6.81(10^{-3} \text{ kg/m/s})}{(0.02664 \text{ m})(u_2)(1000 \text{ kg/m}^3)} \right)^{0.9} \right] \quad (\text{E19.7b})$$

Equations (E19.7a) and (E19.7b) are solved simultaneously to give $f = 0.0062$ and $u_2 = 3.04 \text{ m/s}$. Using the relationships between velocity, volumetric flowrate, and mass flowrate, the results are

$\dot{v}_2 = 1.69 \times 10^{-3} \text{ m}^3/\text{s}$ and $\dot{m} = 1.69 \text{ kg/s}$. Now, the Reynolds number must be checked using the calculated velocity, and $\text{Re} = 80,960$, so the turbulent flow assumption is valid.

Example 19.8

Number 6 fuel oil ($\mu = 800 \text{ cP}$, $\rho = 62 \text{ lb/ft}^3$) flows in a 1.5-in, schedule-40 pipe over a distance of 1000 ft. The discharge point is 20 ft above the inlet, and the source and discharge are both at 1 atm. A 15 hp pump that is 75% efficient is used. What is the flowrate in the pipe?

Solution

The mechanical energy balance reduces to

$$g\Delta z + \frac{32fL\dot{v}^2}{\pi^2 D^5} - \frac{\eta_p \dot{W}_s}{\rho \dot{v}} = 0 \quad (\text{E19.8a})$$

The friction expression is in terms of the volumetric flowrate, and in the third term, the mass flowrate in the denominator is also expressed in terms of the volumetric flowrate. The volumetric flowrate is the unknown variable. Given the high viscosity, laminar flow is assumed. This assumption must be checked once a flowrate is calculated. For laminar flow, since $f = 16/\text{Re}$, Equation (E19.8a) becomes

$$g\Delta z + \frac{32L\dot{v}^2}{\pi^2 D^5} \frac{16\pi D\mu}{4\dot{v}\rho} - \frac{\eta_p \dot{W}_s}{\rho \dot{v}} = 0 \quad (\text{E19.8b})$$

where the fourth equality in Equation (19.20) is used for the Reynolds number. All terms are known other than the volumetric flowrate, so

$$\begin{aligned} 32.2 \text{ ft/sec}^2 (20 \text{ ft}) + \frac{128(1000 \text{ ft})(800 \text{ cP})(6.72 \times 10^{-4} \text{ lb/ft/sec/cP})\dot{v}}{\pi \left(\frac{1.610 \text{ in}}{12 \text{ in/ft}} \right)^4 (62 \text{ lb/ft}^3)} \\ - \frac{0.75(15 \text{ hp})(550 \text{ ft lb}_f/\text{sec/hp})(32.2 \text{ ft lb/lb}_f/\text{sec}^2)}{\dot{v}(62 \text{ lb/ft}^3)} = 0 \end{aligned} \quad (\text{E19.8c})$$

The solution is $\dot{v} = 0.054 \text{ ft}^3/\text{sec}$. Checking the Reynolds number,

$$\text{Re} = \frac{4\dot{v}\rho}{\pi D\mu} = \frac{4(0.054 \text{ ft}^3/\text{sec})(62 \text{ lb/ft}^3)}{\pi \left(\frac{1.610 \text{ in}}{12 \text{ in/ft}} \right) (800 \text{ cP})(6.72 \times 10^{-4} \text{ lb/ft/sec/cP})} = 59.1 \quad (\text{E19.8d})$$

so the flow is indeed laminar.

19.3.2.2 Multiple-Pipe Systems

For complex, multiple-pipe systems, including branching or mixing pipe systems, as illustrated in Figure 19.7, there are two sets of key relationships.

For pipes in series, the mass flowrate is constant and the pressure differences are additive:

$$\dot{m}_1 = \dot{m}_2 = \dot{m}_3 \quad (19.21)$$

$$\Delta P = \Delta P_1 + \Delta P_2 + \Delta P_3 \quad (19.22)$$

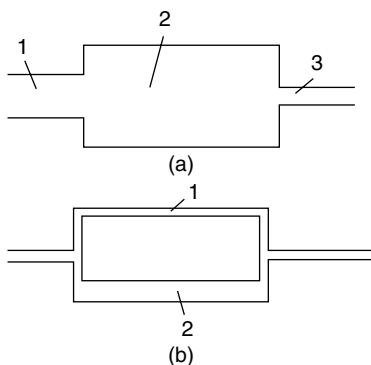

Figure 19.7 Multiple Pipe Systems:
 (a) Pipes of Different Diameters in Series,
 (b) Pipes of Different Diameters in Parallel

For pipes in parallel, the mass flowrates are additive and the pressure differences are equal:

$$\dot{m} = \dot{m}_1 + \dot{m}_2 = \dot{m}_3 \quad (19.23)$$

$$\Delta P_1 = \Delta P_2 = \Delta P_3 \quad (19.24)$$

Equation (19.21) is just the mass balance; the mass flowrate through each section must be constant. Equation (19.22) just means that the pressure drops in all sections in series are additive.

In the case of parallel flow, Equation (19.23) means that the mass flowrates in and out of the parallel section are additive, since mass must be conserved. Equation (19.24) means that the pressure drops in parallel sections are equal. This is because mixing streams must be designed to be at the same pressure, or the flowrates will readjust so the pressures at the mixing point are identical. This concept is discussed in more detail later.

The solution method is to write all of the relevant equations, including the mechanical energy balance, friction factor expression, and mass balance, along with the appropriate constraints from Equations (19.21) through (19.24), and solve the equations simultaneously. It is understood that this method applies to any number of pipes in series or parallel.

Example 19.9

Water flows through a pipe, splits into two parallel pipes, and then the fluids mix into another single pipe, as in Figure 19.7(b). All piping is commercial steel. The equivalent length of Branch 1 is 75 m, and the equivalent length of Branch 2 is 50 m. The elevation at the split point is the same as the elevation at the mixing point. Branch 1 is 2-in, schedule-40 pipe, and Branch 2 is 1.5-in, schedule-40 pipe. The pressure drop across Branch 1 is fixed at 100 kPa. Determine the volumetric flowrate in each branch and the total volumetric flowrate. What information could be obtained if the pressure drop was not provided?

Solution

The mechanical energy balance for both sections reduces to

$$\frac{\Delta P_i}{\rho} + \frac{2f_i L_i u_i^2}{D_i} = 0 \quad (\text{E19.9a})$$

where the subscript i denotes a parallel section of pipe. The kinetic energy terms are not present in Equation (E19.9a) because the control volume is the parallel pipes not including the feed pipe, the mixing point, the split point, and the discharge pipe. There are four unknowns, the friction factor

and velocity in each section. The mechanical energy balance for each section is Equation (E19.9a), and there are two expressions for the friction factor, so the problem can be solved. Because the two branches are in parallel and then mix, the pressure drop in each section is the same, as shown in Equation (19.24), and it is negative, since the downstream pressure is less than the upstream pressure. Initially, turbulent flow will be assumed. The equations are

$$\frac{-100,000 \text{ Pa}}{1000 \text{ kg/m}^3} + \frac{2f_1(75 \text{ m})u_1^2}{0.0525 \text{ m}} = 0 \quad (\text{E19.9b})$$

$$\frac{-100,000 \text{ Pa}}{1000 \text{ kg/m}^3} + \frac{2f_2(50 \text{ m})u_2^2}{0.04089 \text{ m}} = 0 \quad (\text{E19.9c})$$

$$\frac{1}{f_1^{0.5}} = -4 \log_{10} \left[\frac{4.6 \times 10^{-5} \text{ m}}{3.7(0.0525 \text{ m})} + \left(\frac{6.81(10^{-3} \text{ kg/m/s})}{(0.0525 \text{ m})(u_1)(1000 \text{ kg/m}^3)} \right)^{0.9} \right] \quad (\text{E19.9d})$$

$$\frac{1}{f_2^{0.5}} = -4 \log_{10} \left[\frac{4.6 \times 10^{-5} \text{ m}}{3.7(0.04089 \text{ m})} + \left(\frac{6.81(10^{-3} \text{ kg/m/s})}{(0.04089 \text{ m})(u_1)(1000 \text{ kg/m}^3)} \right)^{0.9} \right] \quad (\text{E19.9e})$$

Solving Equations (E19.9b) to (E19.9e) simultaneously gives $f_1 = 0.0053$, $u_1 = 2.57 \text{ m/s}$, $f_2 = 0.0056$, $u_2 = 2.69 \text{ m/s}$. The volumetric flowrates are $\dot{v}_1 = 0.0056 \text{ m}^3/\text{s}$ and $\dot{v}_2 = 0.0035 \text{ m}^3/\text{s}$. While Branch 2 is shorter, the smaller diameter has a stronger effect on the friction, as seen by the fifth-power dependence in Equation (19.14), so Branch 2 has a smaller flowrate.

Finally, the Reynolds numbers must be calculated to prove that the flow is turbulent. The results are $Re_1 = 134,700$, and $Re_2 = 110,160$, so the flow is indeed turbulent.

When streams mix, the pressure will be the same. If a pipe system is designed such that the pressures at a mixing point are not the same, the flowrates will adjust (as illustrated in Example 19.9) to make the mixing-point pressures identical, and the flowrates will not be as designed. This is important because steady-state process simulators allow streams to be mixed at different pressures, and the lowest pressure is taken as the outlet pressure unless an outlet pressure or a mixing-point pressure drop is specified. Just because steady-state process simulators allow this to be done does not make it physically correct. Valves are used to reduce higher pressures to make the pressures equal at a mixing point. When using simulators, it is the user's responsibility to include appropriate devices to make the simulation correspond to reality.

19.3.3 Compressible Flow

For compressible flow, the integral in the mechanical energy balance in Equation (19.5) must be evaluated, since the density is not constant. There are two limiting cases for frictional flow through a pipe section: isothermal flow and adiabatic flow. For isothermal flow of an ideal gas, the density is expressed as

$$\rho = \frac{PM}{RT} \quad (19.25)$$

where M is the molecular weight, and the integral can be evaluated. For adiabatic, reversible flow of an ideal gas, the temperature in Equation (19.25) is expressed in terms of pressure to evaluate the integral in Equation (19.5) using a relationship obtained from thermodynamics:

$$T = T_1 \left(\frac{P}{P_1} \right)^{\frac{\gamma-1}{\gamma}} \quad (19.26)$$

where

$$\gamma = \frac{C_p}{C_v} \quad (19.27)$$

where C_p and C_v are the constant pressure and constant volume heat capacities, respectively. The results are expressed in terms of the superficial mass velocity, G . For isothermal, turbulent flow, the result, presented without derivation, is

$$\frac{M}{2RT}(P_2^2 - P_1^2) + G^2 \ln\left(\frac{P_1}{P_2}\right) + \frac{2fL_{eq}G^2}{D} = 0 \quad (19.28)$$

which can be solved for an unknown pressure, superficial mass velocity (G), diameter (by expressing superficial mass velocity in terms of diameter), or length. For isothermal, laminar flow, the result is

$$\frac{M}{4RT}(P_2^2 - P_1^2) + G^2 \ln\left(\frac{P_1}{P_2}\right) + \frac{16\mu L_{eq}}{D^2} = 0 \quad (19.29)$$

Equation (19.29) is a quadratic in G , or if G is known, any other variable can be found. For adiabatic, turbulent flow, the result is

$$\frac{\gamma}{\gamma+1} \frac{M}{RT_1} P_1^2 \left[1 - \left(\frac{P_2}{P_1}\right)^{\frac{\gamma+1}{\gamma}} \right] - \frac{2fL_{eq}}{D} - \frac{1}{\gamma} \ln\left(\frac{P_1}{P_2}\right) = 0 \quad (19.30)$$

For compressible flow in packed beds, the Ergun equation, Equation (19.19), is used for the friction term, and the pressure term in the mechanical energy balance is integrated assuming either isothermal or adiabatic flow. For isothermal flow, the result is

$$\frac{M}{2G^2RT}(P_2^2 - P_1^2) + \frac{L(1-\varepsilon)}{D_p \varepsilon^3} \left[\frac{150\mu(1-\varepsilon)}{D_p u_s \rho} + 1.75 \right] = 0 \quad (19.31)$$

where subscript 1 is upstream and subscript 2 is downstream. Quite often, it is stated that the mechanical energy balance for packed beds, which is the Ergun equation in Equation (19.19), can be used for gases as long as the pressure drop is less than 10% of the average pressure. However, with the computational tools now available, there is really no need for that approximation.

In Equations (19.28) through (19.33), it is assumed that the flow is in a pipe; therefore, there is no work term. The potential energy term is neglected because it is generally negligible for gases due to their low density.

19.3.4 Choked Flow

In evaluating the flow of compressible fluids, there exists a limit for the maximum velocity of the fluid (gas), that is, the speed of sound in the fluid. As an example, consider a pressurized gas in a supply tank (Tank 1) that is connected to a destination tank (Tank 2) via a pipe. Initially, Tank 1 and Tank 2 are at the same pressure, so no gas flows between them. Gradually, the pressure in Tank 2 is reduced and gas starts to flow from Tank 1 to Tank 2. It seems logical that the lower the pressure in Tank 2, the higher the gas flow rate is and the higher is the velocity of gas entering Tank 2. However, at some critical pressure for Tank 2, P_2^* , the flow of gas into Tank 2, reaches sonic velocity (the speed of sound). Decreasing the tank pressure below this critical pressure has no effect on

the exit velocity of the gas entering Tank 2; that is, it remains constant at the speed of sound. This phenomenon of choked flow occurs because the change in downstream pressure must propagate upstream for the change in flow to occur. The speed at which this propagation occurs is the speed of sound. Thus, when the gas velocity is at the speed of sound, any further decrease in downstream pressure cannot be propagated upstream, and the flow cannot increase further. Therefore, there is a critical (maximum) superficial mass velocity of gas, G^* , that can be transferred from Tank 1 to Tank 2 through the pipe. The relationships for critical flow in pipes under turbulent flow conditions are as follows:

Isothermal flow:

$$G^* = \frac{P_2^*}{P_1} \sqrt{P_1 \rho_1} \quad (19.32)$$

and

$$\frac{4fL_{eq}}{D} = \left(\frac{P_1}{P_2^*}\right)^2 - 2\ln\left(\frac{P_1}{P_2^*}\right) - 1 \quad (19.33)$$

Adiabatic flow:

$$G^* = \sqrt{\gamma P_1 \rho_1} \left(\frac{P_2^*}{P_1}\right)^{(\gamma+1)/2\gamma} \quad (19.34)$$

and

$$\frac{4fL_{eq}}{D} = \frac{2}{\gamma+1} \left[\left(\frac{P_1}{P_2^*}\right)^{(\gamma+1)/\gamma} - 1 \right] - \frac{2}{\gamma} \ln\left(\frac{P_1}{P_2^*}\right) \quad (19.35)$$

When evaluating compressible flows, a check for critical flow conditions in the system should always be done. Usually, critical flow is not an issue when $P_2 > 0.5P_1$, but it is always a good idea to check. The use of Equations (19.32) through (19.35) is illustrated in Example 19.10.

Example 19.10

A fuel gas has an average molecular weight of 18, a viscosity of 10^{-5} kg/m s, and a γ value of 1.4. It is sent to neighboring industrial users through 4-in, schedule-40, commercial-steel pipe. One such pipeline is 100 m long. The pressure at the plant exit is 1 MPa, and the required pressure at the receiver's plant is 500 kPa. It is estimated that the gas maintains a constant temperature of 75°C over the entire length of 100 m. Estimate the volumetric flowrate of the fuel gas, metered at 1 atm and 60°C .

Solution

The conditions for critical flow should be checked first, and this requires the simultaneous solution of Equations (19.32) and (19.33) to find P_2^* . An approximation can be made by assuming that the flow is fully developed turbulent and then checking this assumption. For fully developed turbulent flow, from Equation (19.16),

$$\frac{1}{f^{0.5}} = -4 \log_{10} \left[\frac{e}{3.7D} \right] = -4 \log_{10} \left[\frac{4.6 \times 10^{-5} \text{ m}}{3.7(0.1023 \text{ m})} \right] \Rightarrow f = 0.00408 \quad (\text{E19.10a})$$

Substituting in Equation (19.33) gives

$$\frac{4fL_{eq}}{D} \frac{4(0.00408)(100)}{(0.10226)} = \left(\frac{P_1}{P_2^*}\right)^2 - 2\ln\left(\frac{P_1}{P_2^*}\right) - 1 \quad (\text{E19.10b})$$

Solving gives $P_2^* = 223.9 \text{ kPa} < 500 \text{ kPa}$; therefore, the flow is not choked. The actual friction factor is within a few percent of that calculated in Equation (E19.10a), and this difference does not affect the result regarding whether the flow is choked.

Equation (19.28) can now be solved for the superficial mass velocity:

$$G = \left[\frac{\frac{M}{2RT}(P_1^2 - P_2^2)}{\frac{2fL_{eq}}{D} + \ln\left(\frac{P_1}{P_2}\right)} \right]^{0.5} \quad (\text{E19.10c})$$

All terms in Equation (E19.10c) are given other than the friction factor, which must be calculated. So,

$$G = \left[\frac{\frac{18 \text{ kg/kmol}}{2(8314 \text{ m}^3\text{Pa/kmol/K})(348 \text{ K})} \left((10^6 \text{ Pa})^2 - (5 \times 10^5 \text{ Pa})^2 \right)}{\frac{2f(100 \text{ m})}{0.10226 \text{ m}} + \ln\left(\frac{1 \text{ MPa}}{0.5 \text{ MPa}}\right)} \right]^{0.5} \quad (\text{E19.10d})$$

The friction factor, using the ϵ value for commercial steel at the top of Figure 19.6, is

$$\frac{1}{f^{0.5}} = -4 \log_{10} \left[\frac{4.6 \times 10^{-5} \text{ m}}{3.7(0.10226 \text{ m})} + \left(\frac{6.81(10^{-5} \text{ kg/m/s})}{(0.10226 \text{ m})G} \right)^{0.9} \right] \quad (\text{E19.10e})$$

where the Reynolds number is expressed as DG/μ . Equations (E19.10d) and (E19.10e) can be solved simultaneously for G . A possible approximation is to assume fully turbulent flow, as was done when checking for choked flow. In that case, the Reynolds number in the Pavlov equation is assumed to be large, so the friction factor asymptotically approaches a value calculated from only the roughness term. In this case, $f = 0.004077$. Then, from Equation (E19.10d), $G = 518.8 \text{ kg/m}^2\text{s}$. Simultaneous solution of Equations (E19.10d) and (E19.10e) yields $f = 0.00411$ and $G = 516.7 \text{ kg/m}^2\text{s}$, so the fully turbulent approximation is reasonable, even though an exact solution is possible. The Reynolds number is $DG/\mu = 5.28 \times 10^6$, which, from Figure 19.6, is in the fully turbulent, constant-friction-factor region.

Since $G = \dot{m}/A = \rho \dot{v}/A$, using the exact solution, with the density calculated using the ideal gas law $\rho = PM/RT$,

$$\dot{v} = \frac{(516.7 \text{ kg/m}^2\text{s})(0.0082124 \text{ m}^2)}{\left(\frac{101,325 \text{ Pa}(18 \text{ kg/kmol})}{8314 \text{ m}^3\text{Pa/kmol/K}(333 \text{ K})} \right)} = 6.44 \text{ m}^3/\text{s} \quad (\text{E19.10f})$$

It is observed that the temperature and pressure used to calculate the density in Equation (E19.10d) are not the conditions in the pipeline, because the flowrate required is at 1 atm and 60°C. Since the density of gases is a function of temperature and pressure obtained through an equation of state, a volumetric flowrate must have temperature and pressure specified. In the gas industry, where American Engineering units are common, the standard conditions, known as standard cubic feet (SCF), are at 1 atm and 60°F.

If the second tank were at a pressure of $P_2^* = 223.9 \text{ kPa}$ or less, then the superficial mass velocity would be at its maximum value, given by Equation (19.32) (where $\rho_1 = 6.5016 \text{ kg/m}^3$):

$$G^* = \frac{P_2^*}{P_1} \sqrt{P_1 \rho_1} = \frac{223,900}{10^6} \sqrt{(10^6)(6.5016)} = 570.9 \text{ kg/m}^2/\text{s}$$

19.4 OTHER FLOW SITUATIONS

19.4.1 Flow Past Submerged Objects

Objects moving in fluids and fluids moving past stationary, submerged objects are similar situations that are described by the force balance. When an object is released in a stationary fluid, it will either fall or rise, depending on the relative densities of the object and the fluid. The object will accelerate and reach a terminal velocity. The period of acceleration is found through an unsteady-state force balance, which is

$$m \frac{du}{dt} = -(\rho_s - \rho)gV + F_{drag} \quad (19.36)$$

where ρ_s is the object density, and ρ is the fluid density. For solid objects, the density difference most likely will be positive, so the object moves downward due to gravity and the drag force resists that motion—hence the opposite signs of the two terms on the right-hand side of Equation (19.36). However, for a gas bubble in a liquid, for example, the density difference is negative, so the bubble rises and the drag force resists that motion. Since velocity is generally defined as being positive moving away from gravity, because that is the positive direction of the coordinate system, the signs reconcile.

For a sphere, the mass is

$$m = \rho_s V = \rho_s \frac{\pi D_s^3}{6} \quad (19.37)$$

where D_s is the sphere diameter, and the volume is defined in Equation (19.37). The drag force on an object is defined as

$$F_{drag} = C_D \frac{\rho u^2}{2} A_{proj} = C_D \frac{\rho u^2}{2} \frac{\pi D_s^2}{4} \quad (19.38)$$

where C_D is a drag coefficient that may be thought of as an analog to the friction factor, A_{proj} is the projected area normal to the direction of flow, and u is the velocity of the object relative to the fluid. For a sphere, the projected area is that of a circle, as shown in the second equality of Equation (19.38). For a cylinder with transverse flow, this area is that of a rectangle. Equation (19.37), Equation (19.38), and the volume of a sphere may be substituted into Equation (19.36), and integration between the limits of zero velocity at time zero and velocity u at time t yields the transient velocity. The transient velocity approaches the terminal velocity at $t \rightarrow \infty$, which can also be obtained by solving for velocity in Equation (19.36) when $du/dt = 0$, that is, at steady state, when the sum of the forces on the object equal zero. The terminal velocity is

$$u_t^2 = \frac{4(\rho_s - \rho)gD_s}{3C_D\rho} \quad (19.39)$$

An expression for the drag coefficient is now needed, just as an expression for the friction factor was needed for pipe flow. Similar to pipe flow, there are different flow regimes with different drag coefficients. The Reynolds number for a sphere is defined as $Re = D_s u_t \rho / \mu$, where the density and viscosity are always that of the fluid, and if $Re \ll 1$, which is called **creeping flow**, this is the Stokes flow regime. Stokes' law, which is a theoretical result, states that the drag force in Equation (19.36) is defined as

$$F_d = 3\pi\mu D_s u_t \quad (19.40)$$

which yields

$$C_D = \frac{24}{Re} \quad (19.41)$$

Stokes' law must be applied only when it is valid, even though its use makes the mathematical results much simpler. In addition to the Reynolds number constraint, the assumptions involved in Stokes' law are a rigid sphere and that gravity is the only body force. An example of another body force is electrostatic force; therefore, Stokes' law may fail for charged objects. Theoretically, there are two drag force components for flow past an object. This is based on the concept that drag is manifested as a pressure drop. Form drag is caused by flow deviations due to the presence of the object. Since the fluid must change direction to flow around the object, energy is "lost," which is manifested as a pressure drop. Frictional drag is analogous to that in a pipe and is due to the contact between the fluid and the object. In Equation (19.40), two-thirds of the total is due to frictional drag and one-third is due to form drag.

Experimental data are usually used as a means to determine the drag coefficient. There are curve fits for the intermediate region, between creeping flow and the constant value observed for $1000 < Re < 200,000$. Haider and Levenspiel [11] provide a curve fit to the data for all values of $Re < 200,000$:

$$C_D = \frac{24}{Re} + 3.3643Re^{-0.3471} + \frac{0.4601Re}{Re + 2682.5} \quad (19.42)$$

and these results are plotted in Figure 19.8.

Equation (19.42) is not convenient for solving the terminal velocity of a sphere falling in a fluid because an iterative solution is required (see Example 19.11). However, this equation may be reformulated in terms of two other dimensionless variables, u_t^* and D^* :

$$u_t^* = \left(\frac{4 Re_t}{3 C_D} \right)^{1/3} = u_t \left[\frac{\rho_f^2}{u(\rho_s - \rho_f)g} \right]^{1/3} \quad (19.43)$$

$$D^* = \left(\frac{3}{4} C_D Re_t^2 \right)^{1/3} = D_{sph} \left[\frac{\rho_f(\rho_s - \rho_f)g}{\mu^2} \right]^{1/3} \quad (19.44)$$

and

$$u_t^* = \left[\frac{18}{(D^*)^2} + \frac{0.591}{(D^*)^{0.5}} \right]^{-1} \quad (19.45)$$

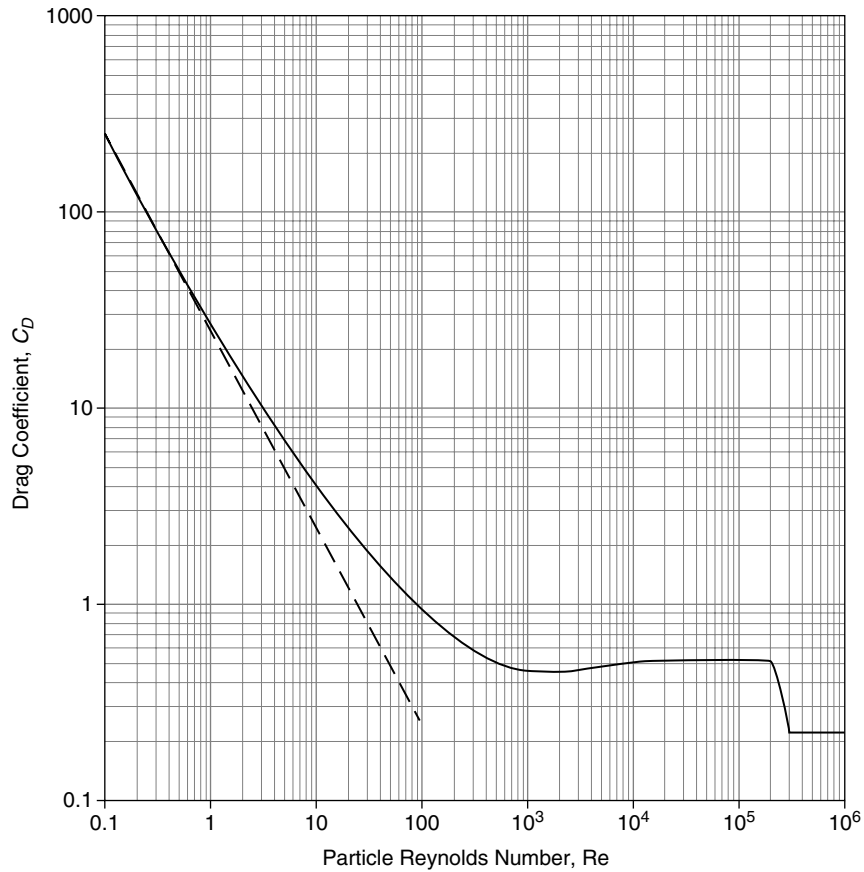

Figure 19.8 Drag Coefficient Dependence on Reynolds Number; the Dotted, Straight Line Is the Creeping Flow Asymptote (From Haider, A and O. Levenspiel, "Drag Coefficient and Terminal Velocity of Spheres and Nonspherical Particles," *Powder Technol.* 58 (1989): 63–70, Equation [19.42])

If the properties of the fluid and particle are known, then D^* can be calculated using Equation (19.44), and then Equation (19.45) can be used to determine u_t^* , and finally u_t can be calculated from Equation (19.43). This is illustrated in Example 19.11.

Example 19.11

In a particular sedimentation vessel, small particles ($SG = 1.2$) are settling in water. The particles have a diameter of 0.2 mm. What is the terminal velocity of the particles?

Solution

Since the particles are small, creeping flow will be assumed initially. Substituting Equation (19.41) into Equation (19.39) yields

$$u_t = \frac{gD^2(\rho_s - \rho)}{18\mu} = \frac{(9.8 \text{ m/s}^2)(2 \times 10^{-4} \text{ m})^2(200 \text{ kg/m}^3)}{18(10^{-3} \text{ kg/m/s})} = 0.0044 \text{ m/s} \quad (\text{E19.11a})$$

Checking the Reynolds number,

$$\text{Re} = \frac{(2 \times 10^{-4} \text{ m})(0.0044 \text{ m/s})(1000 \text{ kg/m}^3)}{10^{-3} \text{ kg/m/s}} = 0.87 \quad (\text{E19.11b})$$

which is not in the creeping flow regime. Therefore, simultaneous solution of Equations (19.39) and (19.42) is required, and the result is $u_t = 0.0039 \text{ m/s}$ and $\text{Re} = 0.78$.

Alternatively, using Equations (19.43), (19.44), and (19.45),

$$D^* = D_{\text{sph}} \left[\frac{\rho_f (\rho_s - \rho_f) g}{\mu^2} \right]^{1/3} \quad (\text{E19.11c})$$

$$D^* = (2 \times 10^{-4} \text{ m}) \left[\frac{(1000)(1200 - 1000)(9.81)}{(1 \times 10^{-3})^2} \right]^{1/3} = 2.504$$

$$u_t^* = \left[\frac{18}{(D^*)^2} + \frac{0.591}{(D^*)^{0.5}} \right]^{-1} = \left[\frac{18}{(2.504)^2} + \frac{0.591}{(2.504)^{0.5}} \right]^{-1} = 0.3082 \quad (\text{E19.11d})$$

$$u_t^* = u_t \left[\frac{\rho_f^2}{\mu (\rho_s - \rho_f) g} \right]^{1/3} \Rightarrow u_t = u_t^* \left[\frac{\mu (\rho_s - \rho_f) g}{\rho_f^2} \right]^{1/3} \quad (\text{E19.11e})$$

$$u_t = (0.3082) \left[\frac{(1 \times 10^{-3})(200)(9.81)}{(1000)^2} \right]^{1/3} = 0.00385 \text{ m/s}$$

For $\text{Re} > 2 \times 10^5$, the phenomenon called **boundary layer separation** occurs. The drag coefficient in this region is $C_D = 0.22$.

With the exception of the boundary layer separation region, Figure 19.8 has about the same shape as Figure 19.6. For low Reynolds numbers, the friction factor and drag coefficient are both inversely proportional to the Reynolds number, though the exact proportionality is different. For large Reynolds numbers, what is generally called **fully turbulent flow**, the friction factor and drag coefficient both approach constant values.

For nonspherical particles, the determination of the drag coefficient and terminal velocity is more complicated. A major challenge is how to account for particle shape. One method is to define the shape in terms of sphericity. Sphericity is defined as

$$\text{Sphericity} = \Psi = \left(\frac{\text{surface area of sphere}}{\text{surface area of particle}} \right)_{\text{same volume}} \quad (19.46)$$

Then, the diameter of a sphere with the same volume as the particle, d_v , is calculated and used in place of the diameter in Equations (19.37) through (19.42). Care is needed when using sphericity, since particles with quite different shapes but similar sphericities may behave quite differently when falling in a fluid.

Example 19.12

Determine the sphericity and D_v of a cube.

Solution

Call the dimension of the cube x . Therefore, D_v is obtained from

$$\frac{\pi D_v^3}{6} = x^3 \quad (\text{E19.12a})$$

$$D_v = \left(\frac{6x^3}{\pi} \right)^{1/3} = 1.241x \quad (\text{E19.12b})$$

and the sphericity is

$$\Psi_{cube} = \frac{\pi D_v^2}{6x^2} = \frac{\pi(1.241x)^2}{6x^2} = 0.806 \quad (\text{E19.12c})$$

Haider and Levenspiel (1989) have provided a curve fit for previously published experimental data, which were taken for regular geometric shapes. The drag coefficient for different sphericities is illustrated in Figure 19.9, and the curve-fit equation is

$$C_D = \frac{24}{\text{Re}} \left[1 + (8.1716e^{-4.0655\Psi}) \text{Re}^{0.0964+0.5565\Psi} \right] + \frac{73.69e^{-5.0748\Psi} \text{Re}}{\text{Re} + 5.378e^{6.2122\Psi}} \quad (\text{19.47})$$

where $\text{Re} = D_v u_t \rho / \mu$.

The equivalent expression in terms of D^* and u_t^* is given as

$$u_t^* \left[\frac{18}{(D^*)^2} + \frac{2.335 - 1.745\Psi}{(D^*)^{0.5}} \right]^{-1} \quad \text{with } D^* = D_v \left[\frac{\rho_f (|\rho_s - \rho_f|) g}{\mu^2} \right]^{1/3} \quad (\text{19.48})$$

where D_v is the diameter of a sphere with the same volume as the particle.

Equation (19.39) can be solved for one unknown by using either Equation (19.41) or Equation (19.42) for the drag coefficient. For example, the viscosity of a fluid can be determined by measuring the terminal velocity of a falling sphere. Or, the terminal velocity of an object can be determined if all of the fluid and particle physical properties are known. If the Reynolds number is

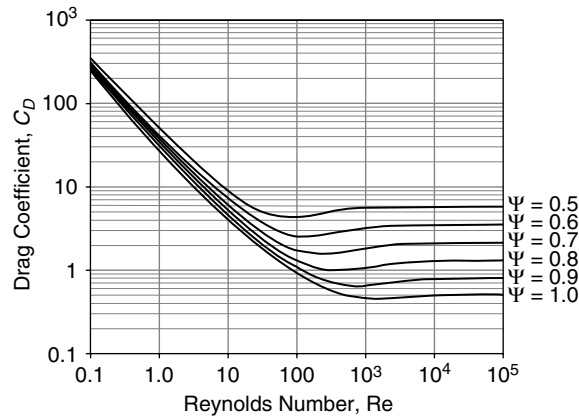

Figure 19.9 Drag Coefficient Dependence on Reynolds Number and Sphericity from Haider and Levenspiel (1989), Equation (19.47)

unknown, then the flow regime is unknown. Therefore, depending on the type of problem being solved, judgment may be needed to assume a flow regime, the assumption must be checked, and iterations may be required to get the correct answer.

19.4.2 Fluidized Beds

If fluid flows upward through a packed bed, at a high enough velocity, the particles become buoyant and float in the fluid. For this condition, the upward drag on the particles is equal to the weight of the particles and is called the *minimum fluidization velocity*, and the particles are said to be fluidized. This is one reason why flow through packed beds is usually downward. The benefits of fluidization are that once the particles are fluidized, they can circulate and the bed of solids mixes. If the upward fluid velocity is sufficiently high, then the bed of particles becomes well mixed (like a continuous stirred tank reactor) and approaches isothermal behavior. For highly exothermic reactions, this property is very desirable. Fluidized beds are often used for such reactions and are discussed in Chapter 22, "Reactors." Fluidized beds are also used in drying and coating operations where the movement of solids is desirable to increase heat and/or mass transfer. As the fluid velocity upward through the bed of particles increases, the mixing of particles becomes more vigorous and there is a tendency for particles to be flung upward and elutriate from the bed. Therefore, a cyclone is typically part of a fluidized bed to remove the entrained particles and recirculate them to the fluidized bed. Another desirable feature of fluidized beds is that they can be used with very small catalyst particles without a large pressure drop. For very small catalyst particles in a packed bed, the pressure drop becomes very large. An example of such a catalyst is the fluid catalytic cracking catalyst used in petroleum refining to make smaller hydrocarbons from large ones.

The general shape of the pressure drop versus superficial fluid velocity in a fluidized bed is shown in Figure 19.10.

The region to the left of u_{mf} is described by the Ergun equation for packed beds because, before fluidization begins, behavior is that of a packed bed. If the particles were restricted, by, say, placing a wire screen on top of the bed, then the bed would continue to behave as a packed bed beyond the u_{mf} . Assuming that the top of the bed is unrestricted, once there is sufficient upward velocity, and hence upward force, the particles begin to lift. This is called **minimum fluidization**. At minimum fluidization, the upward force is equal to the weight of the particles. Hence, the frictional force equals the weight of the bed, and the pressure drop remains constant. Quantitatively,

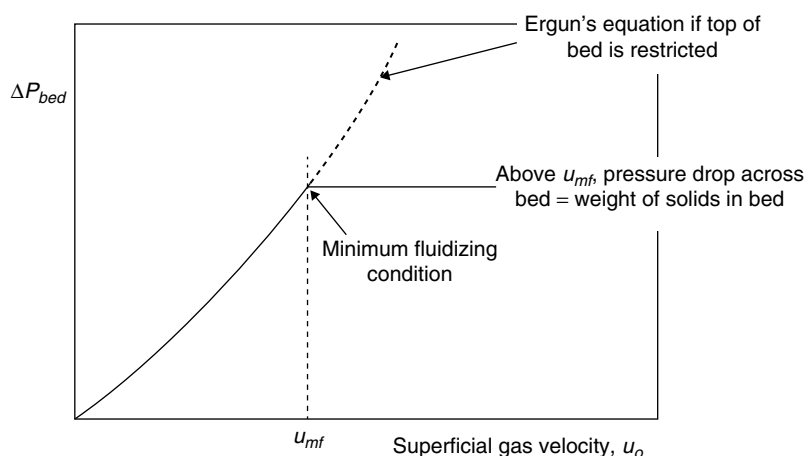

Figure 19.10 Plot Illustrating Constant Value of Pressure Drop above Minimum Fluidization Velocity

$$-\Delta P_{fr} A_t = V_{solids} (\rho_s - \rho_f) g = A_t h_{mf} (1 - \varepsilon_{mf}) (\rho_s - \rho_f) g \quad (19.49)$$

where the subscript *mf* signifies minimum fluidization and h_{mf} is the height of the bed at minimum fluidization, which for a packed bed is called the length of the bed, L . At the instant at which fluidization begins, the frictional pressure drop is equal to that of a packed bed. Combining Equation (19.19), which is the frictional loss in a packed bed and equals $-\Delta P_{fr}/\rho$, and Equation (19.49) yields

$$h_{mf} (1 - \varepsilon_{mf}) (\rho_s - \rho_f) g = \frac{\rho_f h_{mf} u_{mf}^2 (1 - \varepsilon_{mf})}{D_p \varepsilon_{mf}^3} \left[\frac{150 \mu (1 - \varepsilon_{mf})}{D_p \mu_{mf} \rho_f} + 1.75 \right] \quad (19.50)$$

Rearranging Equation (19.50) and defining two dimensionless groups that characterize the fluid flow in a fluidized bed,

$$\text{Re}_{mf} = \frac{D_p u_{mf} \rho_f}{\mu} \quad (19.51)$$

$$\text{Ar} = \frac{D_p^3 \rho (\rho_s - \rho_f) g}{\mu^2} \quad (19.52)$$

where Equation (19.51) is the particle Reynolds number, which characterizes the flow regime, and Equation (19.52) defines the Archimedes number, which is the ratio of gravitational forces/viscous forces, yields

$$\frac{1.75}{\varepsilon_{mf}^3} \text{Re}_{mf}^2 + \frac{150(1 - \varepsilon_{mf})}{\varepsilon_{mf}^3} \text{Re}_{mf} - \text{Ar} = 0 \quad (19.53)$$

Equation (19.53) is a quadratic in Re_{mf} , so the minimum fluidization velocity can be obtained if the physical properties of the solid and fluid are known. For nonspherical particles, the result is

$$\frac{1.75}{\Psi \varepsilon_{mf}^3} \text{Re}_{mf}^2 + \frac{150(1 - \varepsilon_{mf})}{\Psi^2 \varepsilon_{mf}^3} \text{Re}_{mf} - \text{Ar} = 0 \quad (19.54)$$

If the void fraction at minimum fluidization, which must be measured, and/or the sphericity are not known, Wen and Yu [12] recommend using

$$\Psi \varepsilon_{mf}^3 = \frac{1}{14} \quad (19.55)$$

$$\frac{(1 - \varepsilon_{mf})}{\Psi^2 \varepsilon_{mf}^3} = 11 \quad (19.56)$$

and Equation (19.54) reduces to

$$\text{Re}_{mf} = \left[(33.7)^2 + 0.0408 \text{Ar} \right]^{1/2} - 33.7 \quad (19.57)$$

Since the volume of solid particles remains constant, it is possible to relate the bed height and void fraction at different levels of fluidization.

$$h_{mf} (1 - \varepsilon_{mf}) = h_f (1 - \varepsilon_f) \quad (19.58)$$

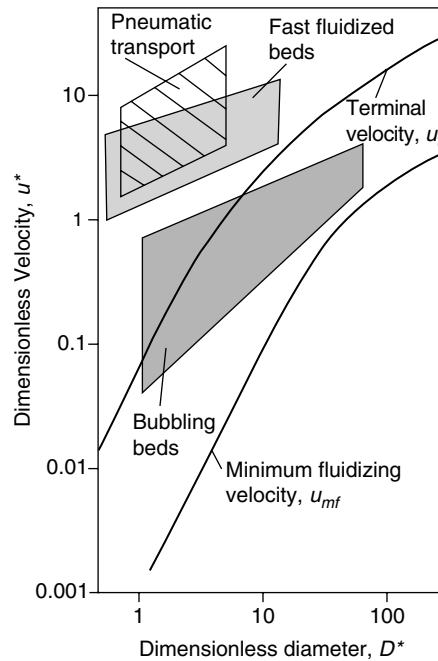

Figure 19.11 Flow Regime Map for Gas-Solid Fluidization (Modified from Kunii, D., and O. Levenspiel, *Fluidization Engineering*, 2nd ed. [Stoneham, MA: ButterworthHeinemann, 1991])

Equation (19.58) is understood by multiplying each side of the equation by A_p , the total bed area, so each side of the equation is the volume of particles because $(1 - \epsilon)$ is the solid fraction, and hA_t is the total bed volume. The operation of fluidized beds above u_{mf} varies considerably on the basis of the size of particles and the superficial velocity of gas. One way to describe the behavior of these beds is through the flow map by Kunii and Levenspiel [13] in Figure 19.11. In Figure 19.11, u^* and D^* refer to the dimensionless velocity and particle size introduced in Section 19.4.1, except that the superficial velocity of the gas through the bed (not the particle terminal velocity) is used in u^* .

It is clear from this figure that operation of fluidized beds can occur over a wide range of operating velocities from u_{mf} to several times the terminal velocity. For turbulent (lying above bubbling beds) and fast fluidized beds, internal and external cyclones must be employed, respectively. The gas and solids flow patterns in all these regimes are very complex and can be found only by experimentation or possibly by using complex computational fluid dynamics codes.

19.4.3 Flowrate Measurement

The traditional method for measuring flowrates is to add a restriction in the flow path and measure the pressure drop. The pressure drop can be related to the velocity and flowrate by the mechanical energy balance. More modern instruments include turbine flow meters that measure flowrate directly and vortex shedding devices.

The types of restrictions used are illustrated in Figure 19.12.

The control volume is fluid between an upstream point, labeled 1, and a point in the obstruction, labeled 2. For turbulent flow, the mechanical energy balance written between these two points is

$$\frac{P_2 - P_1}{\rho} + \frac{u_2^2 - u_1^2}{2} + e_f = 0 \quad (19.59)$$

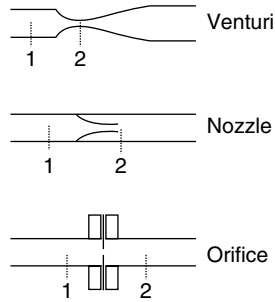

Figure 19.12 Typical Devices Used to Measure Flowrate

The friction term is dropped at this point but is incorporated into the problem through a discharge coefficient, C_o . From Equation (19.3), u_1 is expressed in terms of u_2 , the cross-sectional areas, and then the diameters; solving for the velocity in the obstruction yields

$$u_2 = C_o \left[\frac{2(P_1 - P_2)}{\rho(1 - \beta^4)} \right]^{0.5} \quad (19.60)$$

where

$$\beta = \frac{D_2}{D_1} \quad (19.61)$$

The flowrate can then be obtained by multiplying the velocity in the restriction by the cross-sectional area of the restriction. The term C_o , a discharge coefficient, is added to account for the frictional loss in the restriction. Figure 19.13 shows C_o as a function of β and the bore (restriction) Reynolds number for an orifice, one of the most common restrictions used. Since C_o is not known, the asymptotic value of 0.61 for high-bore Reynolds number is assumed, and iterations may be required if the bore Reynolds number is not above about 20,000. This calculation method is illustrated in Example 19.13.

Other flow measurement devices are used. One such device is the rotameter that has a float that moves within a variable area vertical tube. The level of the float in the device is related to the flowrate, as illustrated in Figure 19.14. As the fluid flow increases, the drag on the float increases and it moves up, but the annular flow area around the float also increases. Consequently, the float comes to a new equilibrium position at which its weight is just balanced by the upward drag force of the fluid. Rotameters are still found in laboratories and provide accurate measurements for both gas and liquid flows. While there is a theoretical description of how a rotameter works, it is typically calibrated by measuring the flowrate versus the height of the float for the given fluid of interest.

Measuring pressure differences is automated in a chemical plant through the use of various devices. However, manometers may still be found in laboratories. Manometers work by having an immiscible fluid of higher density than the flowing fluid in a U-shaped tube, with one end of the tube connected to the pipe at Location 1 and the other end connected as close as possible to Location 2. The height difference between the levels of the immiscible fluid is a measure of the pressure difference between Locations 1 and 2. Figure 19.15 illustrates a general manometer, where the pipe in which the fluid is flowing may be inclined.

The manometer is an example of fluid statics, so the pressure at any horizontal location must be the same in each manometer leg. For the pressure at height 3 in Figure 19.15,

$$P_1 + \rho_A g(z_1 - z_3) = P_2 + \rho_A g(z_2 - z_4) + \rho_B g(z_4 - z_3) \quad (19.62)$$

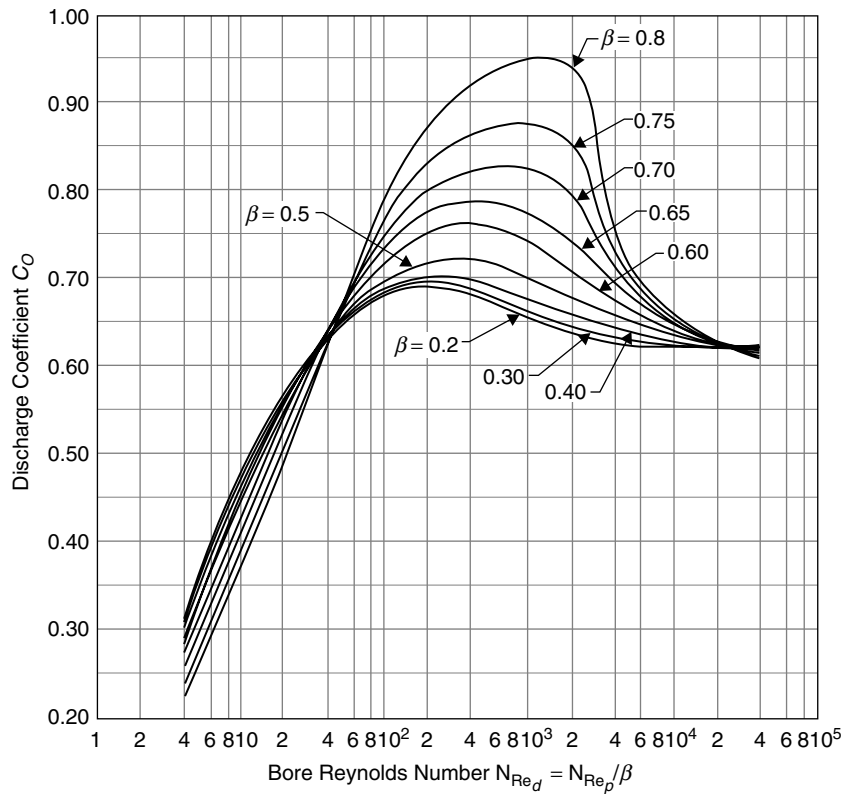

Figure 19.13 Orifice Discharge Coefficient (From Miller, R. W., *Flow Measurement Engineering Handbook* [New York: McGraw-Hill, 1983] [14])

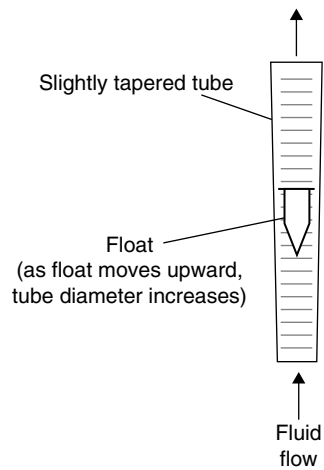

Figure 19.14 Illustration of Rotameter

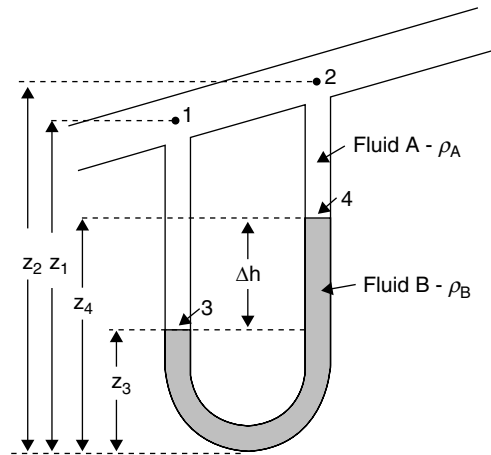

Figure 19.15 Illustration of General Manometer Situation

Equation (19.62) can be rearranged into the “general” manometer equation:

$$P_1 - P_2 + g\Delta h(\rho_A - \rho_B) + \rho_A g(z_1 - z_2) = 0 \quad (19.63)$$

where

$$\Delta h = (z_4 - z_3) \quad (19.64)$$

The third term in Equation (19.63) is zero if the pipe is horizontal. It is important to understand that $z_1 - z_2$ is a difference in vertical distance (height), not a distance along the pipe, and that the coordinate system points upward, so a high height minus a low height is a positive number.

Example 19.13

An orifice having a diameter of 1 in is used to measure the flowrate of an oil ($SG = 0.9$, $\mu = 50$ cP) in a horizontal, 2-in, schedule-40 pipe at 70°F. The pressure drop across the orifice is measured by a mercury ($SG = 13.6$) manometer, which reads 2.0 cm. Calculate the volumetric flowrate of the oil.

Solution

Two steps are involved. First, the pressure drop is calculated from the manometer information. Then, the flowrate is calculated.

To calculate the pressure drop, Equation (19.62) is used, but since the pipe is horizontal, the third term on the right-hand side is zero. The result is

$$P_1 - P_2 = g\Delta h(\rho_B - \rho_A) = \frac{32.2 \text{ ft/sec}^2}{32.2 \text{ ft/lb}_f/\text{sec}^2} \left(2 \text{ cm} \frac{1 \text{ in}}{2.54 \text{ cm}} \right) (13.6 - 0.9)(62.4 \text{ lb/ft}^3) \left(\frac{\text{ft}}{12 \text{ in}} \right)^3 = 0.361 \text{ psi} \quad (\text{E19.13a})$$

Next, the pressure drop is used in Equation (19.60) with the initial assumption that $C_o = 0.61$. So

$$u_2 = 0.61 \left[\frac{2(0.361 \text{ lb}_f/\text{in}^2)(12 \text{ in}/\text{ft})^2(32.2 \text{ ft lb}/\text{lb}_f/\text{sec}^2)}{0.9(62.4 \text{ lb}/\text{ft}^3) \left[1 - \left(\frac{1 \text{ in}}{2.067 \text{ in}} \right)^4 \right]} \right] = 4.84 \text{ ft}/\text{sec} \quad (\text{E19.13b})$$

Now, the bore Reynolds number must be checked.

$$\text{Re} = \frac{(1/12 \text{ ft})(4.84 \text{ ft}/\text{sec})(62.4 \text{ lb}/\text{ft}^3)}{50 \text{ cP} (6.72 \times 10^{-4} \text{ lb}/\text{ft}/\text{sec}/\text{cP})} = 749 \quad (\text{E19.13c})$$

From Figure 19.13, with $\beta = 0.48$ and $\text{Re} = 749$, $C_o \approx 0.71$. Repeating the calculation in Equation (E19.11b) gives $u_2 = 5.63 \text{ ft}/\text{sec}$ and $\text{Re} = 872$. Within the error of reading Figure 19.12, $C_o \approx 0.71$, so the iteration is completed. The volumetric and mass flowrates can now be calculated:

$$\dot{v} = (5.63 \text{ ft}/\text{sec})(0.02330 \text{ ft}^2) = 0.131 \text{ ft}^3/\text{sec} \quad (\text{E19.13d})$$

$$\dot{m} = (0.131 \text{ ft}^3/\text{sec})(62.4 \text{ lb}/\text{ft}^3) = 8.19 \text{ lb}/\text{sec} \quad (\text{E19.13e})$$

When fluid flows through an orifice, the pressure decreases because the velocity increases through the small cross-sectional area of the orifice. Physically, this is because pressure energy is converted to kinetic energy. This is similar to a nozzle, as illustrated in Example 19.3. Subsequently, when the velocity decreases as the cross-sectional area increases to the total pipe area, the pressure increases again. However, not all of the pressure is “recovered,” due to circulating fluid flow at the pipe-orifice diameter. The permanent pressure loss requires incremental pump power, and that is part of the cost of measuring the flowrate using an orifice or nozzle. The amount of recovered pressure has been correlated as a function of β for different flow measuring devices, and it is illustrated in Figure 19.16.

Example 19.14

For Example 19.13, how much additional power is needed for the permanent pressure loss through the orifice? The pump is 75% efficient.

Solution

For $\beta \approx 0.5$, from Figure 19.16, the permanent pressure loss is about 73%. From the mechanical energy balance,

$$\frac{0.73(P_1 - P_2)}{\rho} - \frac{\eta_p \dot{W}_s}{\dot{m}} = 0 \quad (\text{E19.14a})$$

$$\frac{(0.73)(0.361 \text{ lb}_f/\text{in}^2)(12 \text{ in}/\text{ft})^2}{0.9(62.4 \text{ lb}/\text{ft}^3)} = \frac{0.75 \dot{W}_s}{8.19 \text{ lb}/\text{sec}} \quad (\text{E19.14b})$$

so

$$\dot{W}_s = 7.38 \text{ ft lb}_f/\text{sec} = 0.0134 \text{ hp} \quad (\text{E19.14c})$$

This result shows that, while there is a cost associated with an orifice, it is small.

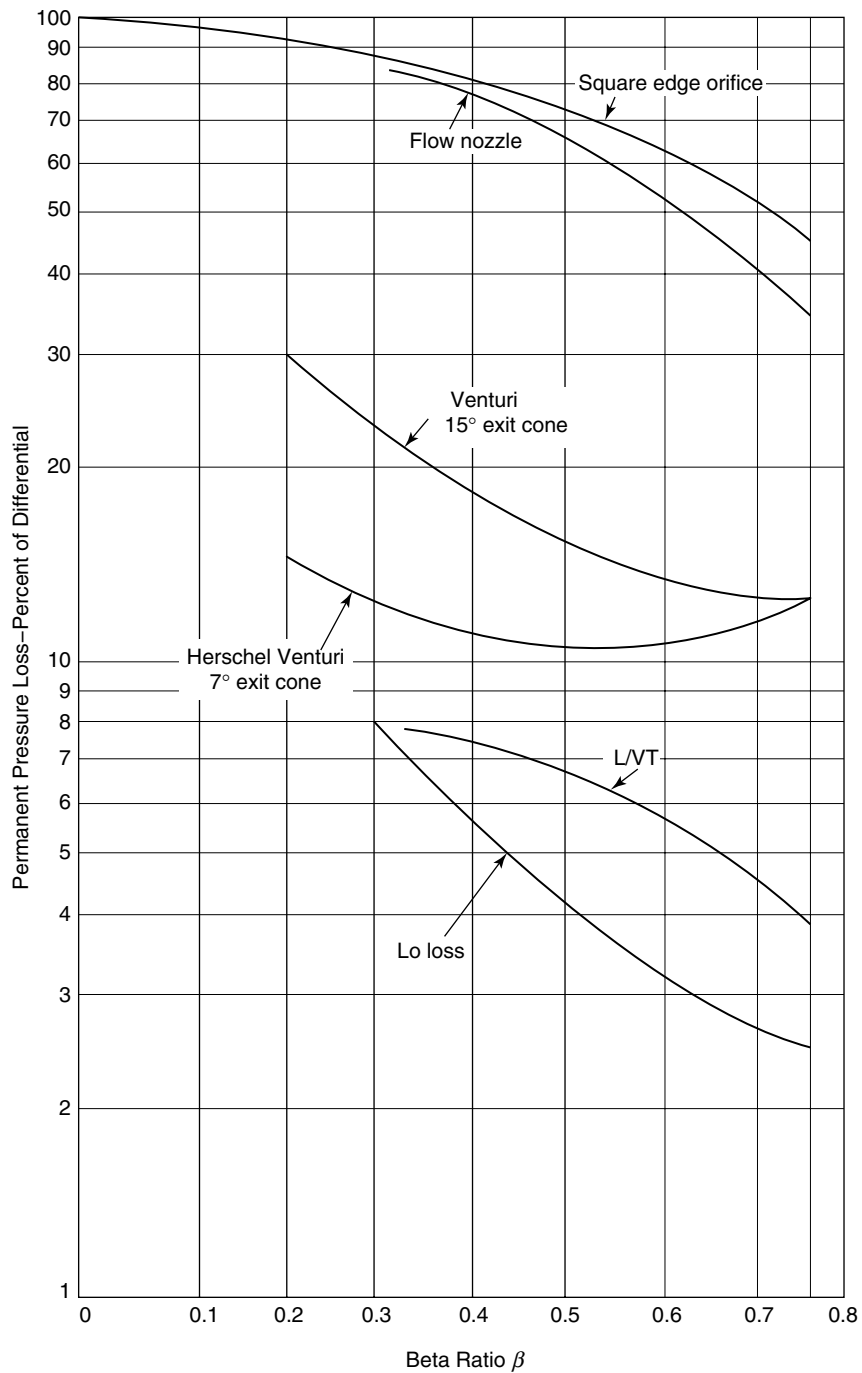

Figure 19.16 Unrecovered Frictional Loss in Different Flow Measuring Devices (Adapted by permission from Cheremisinoff, N. P., and P. N. Cheremisinoff, *Instrumentation for Process Flow Engineering* [Lancaster: Technomic, 1987] [15])

19.5 PERFORMANCE OF FLUID FLOW EQUIPMENT

In addition to equipment design, the chemical engineer must deal with the performance of existing equipment. The differences between the design problem (also called a *rating* problem) (a) and the performance problem (b) are illustrated in Figure 19.17. The use of italics indicates the unknowns in the particular problem. In the design problem, the input and the desired output are specified, and the equipment is designed to satisfy those constraints. In the performance problem, the input and equipment are specified, and the output is determined. The performance problem is what is involved in dealing with day-to-day operations in a chemical plant.

Several different types of problems in frictional fluid flow using the mechanical energy balance were discussed in Section 19.3. Determining the pump power needed for a given situation is a design problem. Similarly, determining the required pipe diameter is a design problem. On the other hand, determining the flowrate when all equipment is specified is a performance problem, as is determining the pressure change for an existing system.

Suppose it is necessary to increase the capacity of a process without adding new equipment. Logically, all flowrates must increase. This is a performance problem, since the input and equipment are specified, and the output must be determined for each unit in the process. Somewhere in the process, the amount of scale-up needed will be limited due to equipment constraints, and this limiting unit is called a **bottleneck**. The process of finding a solution that removes the bottleneck is called **debottlenecking**, which is a performance problem. Similarly, if there is a problem with the output of a process (purity or temperature, for example), the cause of the problem must be determined, which is called **troubleshooting**.

Returning to the situation in which process capacity must be increased, for the fluid flow component, initially, it may appear that problems similar to those in Section 19.3 must be solved from scratch. However, for many situations, not just in fluid flow, very good approximations can be made with a much simpler analysis.

19.5.1 Base-Case Ratios

The ability to predict changes in a process design or in plant operations is improved by anchoring an analysis to a base case. This calculation tool combines use of fundamental relationships with plant operating data to form a basis for predicting changes in system behavior. As will be seen, it is applicable to problems involving all chemical process units when analytical expressions are available.

For design changes, it is desirable to identify a design proven in practice as the base case. For operating plants, actual data are available and are chosen as the base case. It is important to

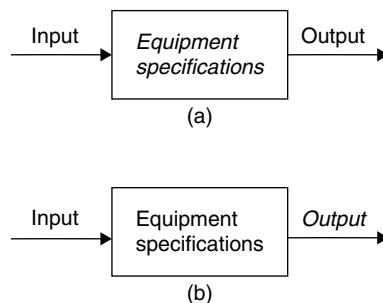

Figure 19.17 Illustrations of (a) Design Problem and (b) Performance Problem (Unknowns Are Indicated by Italics for Each Case)

put this base case into perspective. Assuming that there are no instrument malfunctions and these operating data are correct, then these data represent a real operating point at the time the data were taken. As the plant ages, the effectiveness of process units changes and operations are altered to account for these changes. As a consequence, recent data on plant operations should be used in setting up the base case.

The base-case ratio integrates the “best available” information from the operating plant with design relationships to predict the effect of process changes. It is an important and powerful technique with a wide range of applications. The base-case ratio, X , is defined as the ratio of a new-case system characteristic, x_2 , to the base-case system characteristic, x_1 :

$$X \equiv x_2 / x_1 \quad (19.65)$$

Using a base-case ratio often reduces the need for knowing actual values of physical properties (physical properties refer to thermodynamic and transport properties of fluids), equipment, and equipment characteristics. The values identified in the ratios fall into three major groups. They are defined below and applied in Examples 19.15 and 19.16.

- 1. Ratios Related to Equipment Sizes** (equivalent length, L_{eq} ; diameter, D ; surface area, A): Assuming that the equipment is not modified, these values are constant, the ratios are unity, and these terms cancel out.
- 2. Ratios Related to Physical Properties** (such as density, ρ ; viscosity, μ): These values can be functions of material composition, temperature, and pressure. Only the functional relationships, not absolute values, are needed. For small changes in composition, temperature, or pressure, the properties often are unchanged, and the ratio is unity and cancels out. An exception to this is gas-phase density.
- 3. Ratios Related to Stream Properties:** These ratios usually involve velocity, flowrate, concentration, temperature, and pressure.

Using the base-case ratio eliminates the need to know equipment characteristics and reduces the amount of physical property data needed to predict changes in operating systems.

The base-case ratio is a powerful and straightforward tool to analyze and predict process changes. This is illustrated in Example 19.15.

Example 19.15

It is necessary to scale up production in an existing chemical plant by 25%. Your job is to determine whether a particular pump has sufficient capacity to handle the scale-up. The pump's function is to provide enough pressure to overcome frictional losses between the pump and a reactor.

Solution

The relationship for frictional pressure drop is obtained from the mechanical energy balance:

$$\frac{\Delta P}{\rho} = -\frac{2fLu^2}{D} \quad (E19.15a)$$

This relationship is now written as the ratio of two cases, where subscript 1 indicates the base case, and subscript 2 indicates the new case:

$$\frac{\Delta P_2}{\Delta P_1} = \frac{2\rho_2 f_2 L_{eq2} u_2^2 D_1}{2\rho_1 f_1 L_{eq1} u_1^2 D_1} \quad (E19.15b)$$

Because the pipe has not been changed, the ratios of diameters (D_2/D_1) and lengths (L_{eq2}/L_{eq1}) are unity. Because a pump is used only for liquids, and liquids are (practically) incompressible, the ratio of densities is unity. If the flow is assumed to be fully turbulent, which is usually true for process applications, the friction factor is not a function of Reynolds number. This fact should be checked for a particular application. Figure 19.6 illustrates how, for fully turbulent flow in pipes that are not hydraulically smooth, the friction factor approaches a constant value. Since the x -axis is a log scale, changes up to a factor of 2 to 5, which are well beyond the scale-up capability of most equipment, do not represent much of a difference on the graph. Therefore, the friction factor is constant, and the ratio of friction factors is unity. The ratio in Equation (E19.15b) reduces to

$$\frac{\Delta P_2}{\Delta P_1} = \frac{u_2^2}{u_1^2} = \frac{\dot{m}_2^2 / A_2^2 \rho_2^2}{\dot{m}_1^2 / A_1^2 \rho_1^2} = \frac{\dot{m}_2^2}{\dot{m}_1^2} \quad (\text{E19.15c})$$

where the second equality is obtained by substituting for u_i in numerator and denominator using the mass balance $\dot{m}_i = \rho_i A_i u_i$, canceling the ratio of densities for the same reason as above, and canceling the ratio of cross-sectional areas because the pipe has remained unchanged. Therefore, by assigning the base-case mass flow to have a value of 1, for a 25% scale-up, the new case has a mass flow of 1.25, and the ratio of pressure drops becomes

$$\frac{\Delta P_2}{\Delta P_1} = \left(\frac{\dot{m}_2}{\dot{m}_1} \right)^2 = \left(\frac{1.25}{1} \right)^2 = 1.56 \quad (\text{E19.15d})$$

Thus, the pump must be able to deliver enough head to overcome 56% additional frictional pressure drop while pumping 25% more material.

It is important to observe that Example 19.15 was solved without knowing any details of the system. The pipe diameter, length, and number of valves and fittings were not known. The liquid being pumped, its temperature, and its density were not known. Yet the use of base-case ratios along with simple assumptions permitted a solution to be obtained. This illustrates the power and simplicity of base-case ratios.

Example 19.16

It is proposed to improve performance through a section of pipe by adding an identical section in parallel.

- If the total flowrate remains constant, what parameter changes and by how much, assuming the fluid flow is fully turbulent?
- If the original pipe is 1.5-in, schedule-40, commercial steel, and the new section is 2-in, schedule-40, commercial steel, answer the same question as in Part (a).

Solution

- By using the mechanical energy balance and Equation (19.14) for the friction term, with the subscript 1 representing the original case and subscript 2 representing the new case, each being the flow through the original section, the ratio of pressure drops is

$$\frac{\Delta P_2}{\Delta P_1} = \frac{-e_{f2}}{-e_{f1}} = \frac{32\rho_2 f_2 L_{eq2} \dot{v}_2^2}{\pi^2 D_2^5} \frac{\pi^2 D_1^5}{32\rho_1 f_1 L_{eq1} \dot{v}_1^2} \quad (\text{E19.16a})$$

The constants cancel. If the fluid is unchanged, the densities cancel. Since the new and old pipe lengths and diameters are identical, the lengths and diameters cancel. It is assumed that the minor losses due to the elbows and fitting needed to add the parallel pipe are unchanged,

so the equivalent lengths cancel. For fully turbulent flow, the friction factor has asymptotically approached a constant value (Figure 19.6), so the friction factors cancel. So, the result is

$$\frac{\Delta P_2}{\Delta P_1} = \frac{\dot{v}_2^2}{\dot{v}_1^2} \quad (\text{E19.16b})$$

Since the two parallel sections are identical, the flowrate splits equally between the two sections, so the flowrate in the original section is half of the original flowrate:

$$\frac{\Delta P_2}{\Delta P_1} = \frac{\dot{v}_2^2}{\dot{v}_1^2} = \frac{(0.5\dot{v}_1)^2}{\dot{v}_1^2} = 0.25 \quad (\text{E19.16c})$$

Therefore, the pressure drop through that section of pipe decreases by 75%.

- b. In this case, subscripts 1 and 2 represent the flow through the original and new sections, after the parallel section is installed. The analysis starts identically, but the diameters and friction factors do not cancel. The friction factors do not cancel because the asymptotic value for the friction factor in Figure 19.6 and in the Pavlov equation (Equation [19.16]) depends on the ratio of the roughness factor to the diameter, and that ratio is different for the two sections of pipe. The ratio expression becomes

$$\frac{\Delta P_2}{\Delta P_1} = \frac{f_2 \dot{v}_2^2 D_1^5}{f_1 \dot{v}_1^2 D_2^5} \quad (\text{E19.16d})$$

From the Pavlov equation (Equation [19.16]), using the ratio of the friction factors at an asymptotically large Reynolds number and the schedule pipe diameters, Equation (E19.16d) becomes

$$\frac{\Delta P_2}{\Delta P_1} = \frac{\left[\log_{10} \left(\frac{0.0018 \text{ in}}{3.7(1.610 \text{ in})} \right) \right]^2}{\left[\log_{10} \left(\frac{0.0018 \text{ in}}{3.7(2.067 \text{ in})} \right) \right]^2} \frac{(1.610 \text{ in})^5 \dot{v}_2^2}{(2.067 \text{ in})^5 \dot{v}_1^2} = 0.270 \frac{\dot{v}_2^2}{\dot{v}_1^2} \quad (\text{E19.16e})$$

Since the pressure drops in each parallel section must be equal,

$$\frac{\dot{v}_2}{\dot{v}_1} = \left(\frac{1}{0.270} \right)^{0.5} = 1.92 \quad (\text{E19.16f})$$

If the flow is laminar, the analysis would be similar, but the results would differ due to the different expression for the friction factor in laminar flow. Examples of this are the subject of problems at the end of the chapter.

19.5.2 Net Positive Suction Head

There is a significant limitation on pump operation called net positive suction head (NPSH). This is the head that is needed on the pump feed (suction) side to ensure that liquid does not vaporize upon entering the pump. Its origin is as follows. Although the effect of a pump is to raise the pressure of a liquid, frictional losses at the entrance to the pump, between the suction pipe and the internal pump mechanism, cause the liquid pressure to drop upon entering the pump. This means that a minimum pressure exists somewhere within the pump. If the feed liquid is saturated or nearly saturated, the liquid can vaporize upon entering due to this internal pressure drop. This causes formation of vapor bubbles. These bubbles rapidly collapse when exposed to the forces created by the pump mechanism, called *cavitation*. This process usually results in noisy pump

operation and, if it occurs for a period of time, will damage the pump. As a consequence, regulating valves, which lower fluid pressure, are not normally placed in the suction line to a pump.

Pump manufacturers supply NPSH data with a pump, usually in head units. In this book, both head and pressure units are used. The required NPSH, denoted $NPSH_R$, is a function of the square of velocity because it is a frictional loss and because most applications involve turbulent flow. Figure 19.18(a) shows $NPSH_R$ and $NPSH_A$ curves, which define a region of acceptable pump operation. This is specific to a given liquid. Typical $NPSH_R$ values are in the range of 15 to 30 kPa (2-4 psi) for small pumps and can reach 150 kPa (22 psi) for larger pumps. Figure 19.18 also shows curves for $NPSH_A$, the available NPSH, along with the $NPSH_R$ curve.

The available $NPSH_A$ is defined as

$$NPSH_A = P_{inlet} - P^* \tag{19.66}$$

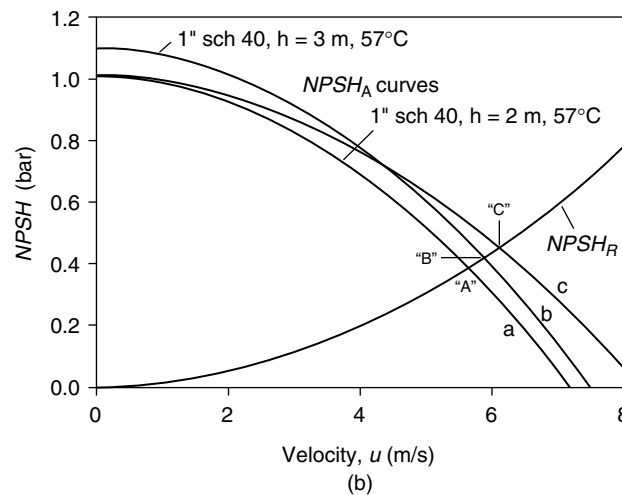
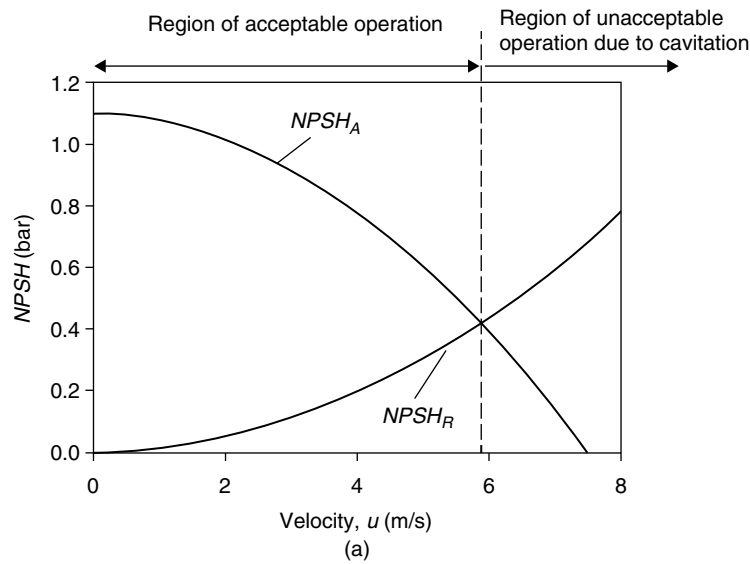

Figure 19.18 (a) $NPSH_A$ and $NPSH_R$ Curves Showing Region of Feasible Operation; (b) How Physical Parameters Affect Shape of $NPSH_A$ Curve

Equation (19.66) means that the available NPSH ($NPSH_A$) is the difference between the inlet pressure, P_{inlet} , and P^* , which is the vapor pressure (bubble-point pressure for a mixture). It is required that $NPSH_A \geq NPSH_R$ to avoid cavitation. Cavitation is avoided if operation is to the left of the intersection of the two curves. It is physically possible to operate to the right of the intersection of the two curves, but doing so is not recommended because the pump will be damaged.

All that remains is to calculate or know the pump inlet conditions in order to determine whether sufficient NPSH ($NPSH_A$) is available to equal or exceed the required NPSH ($NPSH_R$). For example, consider the exit stream from a distillation column reboiler, which is saturated liquid. If it is necessary to pump this liquid, cavitation could be a problem. A common solution to this problem is to elevate the column above the pump so that the static pressure increase minus any frictional losses between the column and the pump provides the necessary NPSH to avoid cavitation. This can be done either by elevating the column above ground level using a metal skirt or by placing the pump in a pit below ground level, although pump pits are usually avoided due to safety concerns arising from accumulation of heavier-than-air gases in the pit.

In order to quantify NPSH, consider Figure 19.19, in which material in a storage tank is pumped downstream in a chemical process. This scenario is a very common application of the NPSH concept. For NPSH analysis, the only portion of Figure 19.19 under consideration is between the tank and pump inlet.

From the mechanical energy balance, the pressure at the pump inlet can be calculated to be

$$P_{inlet} = P_{tank} + \rho gh - \frac{2\rho fL_{eq}u^2}{D} \quad (19.67)$$

which means that the pump inlet pressure is the tank pressure plus the static pressure minus the frictional losses in the suction-side piping. Therefore, by substituting Equation (19.67) into Equation (19.66), the resulting expression for $NPSH_A$ is

$$NPSH_A = P_{tank} + \rho gh - \frac{2\rho fL_{eq}u^2}{D} - P^* \quad (19.68)$$

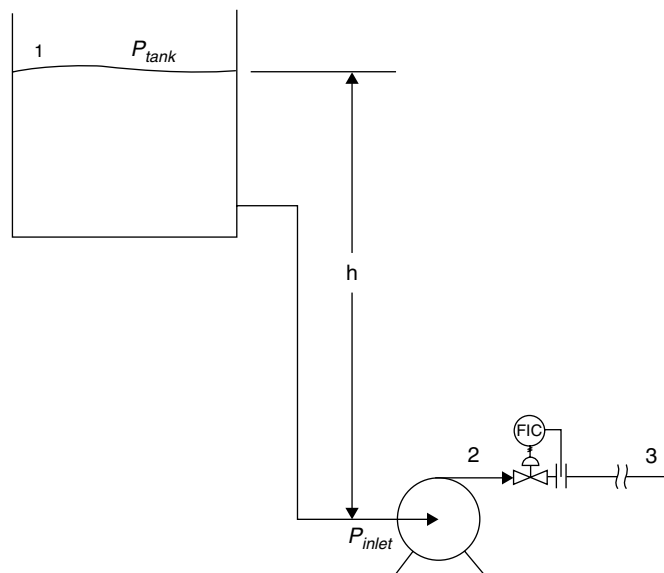

Figure 19.19 Typical Situation for Application of NPSH Principles

This is an equation of a concave downward parabola, of the form $NPSH_A = a - bu^2$, as illustrated in Figure 19.18(b), Curve a. The intercept is $a = P_{\text{tank}} + \rho gh - P^*$ and $b = 2\rho fL_{\text{eq}}/D$. This analysis does not include the kinetic energy term due to the acceleration of the fluid from the tank into the pipe. Rigorously, this term should also be included in the analysis.

If $NPSH_A$ is insufficient for a particular situation, Equation (19.68) suggests methods to increase the $NPSH_A$:

1. Decrease the temperature of the liquid at the pump inlet. This decreases the value of the vapor pressure, P^* , thereby increasing $NPSH_A$. This increases the intercept of the $NPSH_A$ curve while maintaining constant curvature, as illustrated in Figure 19.18(b), Curve b.
2. Increase the static head. This is accomplished by increasing the value of h in Equation (19.64), thereby increasing $NPSH_A$. As was said earlier, pumps are most often found at lower elevations than the source of the material they are pumping. This increases the intercept of the $NPSH_A$ curve while maintaining constant curvature, as illustrated in Figure 19.18(b), Curve b.
3. Increase the tank pressure. This increases the intercept of the $NPSH_A$ curve while maintaining constant curvature, as illustrated in Figure 19.18(b), Curve b.
4. Increase the diameter of the suction line (feed pipe to pump). This reduces the velocity and the frictional loss term, thereby increasing $NPSH_A$. This decreases the curvature of the $NPSH_A$ curve, as illustrated in Figure 19.18(b), Curve c. It is standard practice to have larger-diameter pipes on the suction side of a pump than on the discharge side.

Example 19.17 illustrates how to do NPSH calculations and one of the preceding methods for increasing $NPSH_A$. The other methods are illustrated in problems at the end of the chapter.

Example 19.17

A pump is used to transport toluene at 10,000 kg/h from a feed tank (V-101) maintained at atmospheric pressure and 57°C. The pump is located 2 m below the liquid level in the tank, and there is 6 m of equivalent pipe length between the tank and the pump. It has been suggested that 1-in, schedule-40, commercial-steel pipe be used for the suction line. Determine whether this is a suitable choice. If not, suggest methods to avoid pump cavitation.

Solution

The following data can be found for toluene: $\ln P^*(\text{bar}) = 10.97 - 4203.06/T(\text{K})$, $\mu = 4.1 \times 10^{-4}$ kg/m s, $\rho = 870$ kg/m³. For 1-in, schedule-40, commercial-steel pipe, the roughness factor is about 0.001 and the inside diameter is 0.02664 m. Therefore, the velocity of toluene in the pipe can be found to be 5.73 m/s. The Reynolds number is about 426,000, and the friction factor is $f = 0.005$. At 57°C, the vapor pressure is found to be 0.172 bar.

From Equation (19.68),

$$\begin{aligned} NPSH_A &= 1.01325 \text{ bar} + 870(9.81)(2)(10^{-5}) \text{ bar} \\ &\quad - 2(870)(0.005)(6)(5.73)^2(10^{-5}) / (0.02664) \text{ bar} - 0.172 \text{ bar} \\ NPSH_A &= 0.37 \text{ bar} \end{aligned}$$

This is shown as Point A on Figure 19.18(b). At the calculated velocity, Figure 19.18(b) shows that $NPSH_R$ is 0.40 bar, Point B. Therefore, there is insufficient $NPSH_A$. This means that a 1-in, schedule-40 pipe is unacceptable for this service.

The obvious solution to this problem is to use a larger-diameter pipe for the suction side of the pump. The calculated velocity of 5.73 m/s is far in excess of the typical maximum liquid velocity.

The frictional loss in the 6 m of suction piping is approximately 0.64 bar. If, say, a 2-in, schedule-40 pipe was used for the suction line, then the frictional loss would decrease to approximately 0.02 bar and $NPSH_A$ would increase to about 0.99 bar, which is far in excess of $NPSH_R$. Another method for increasing $NPSH_A$ is to increase the height of liquid in the tank. If the height of liquid in the tank is 3 m, with the original 1-in, schedule-40 pipe at the original temperature, $NPSH_A = 0.445$ bar. This is shown as Point C on Figure 19.18(b).

19.5.3 Pump and System Curves

Pumps also have characteristic performance curves, called *pump curves*. Figure 19.20 illustrates a pump curve for a centrifugal pump. Centrifugal pumps are often called *constant head* pumps because, over a wide range of volumetric flowrates, the head produced by the pump is approximately constant. Pump manufacturers provide the characteristic curve, usually in head units. For centrifugal pumps, the shape of the curve indicates that although the head remains constant over quite a wide range of flowrates, eventually, as the flowrate continues to increase, the head produced decreases. Pump curves also include power and efficiency curves, both of which change with flowrate and head; however, these are not shown here.

For a piping system, a system curve can also be defined. Consider the system as illustrated in Figure 19.21. Location 1 is called the source, and Location 2 is the destination. Location 2 may be distant from Location 1, perhaps at the opposite end of a chemical process and at a different elevation from Location 1. Typical processes have only one pump upstream to supply all pressure needed to overcome pressure losses throughout the process. Therefore, the pressure increase across the pump must be sufficient to overcome all of the losses associated with piping and fittings plus the indicated pressure loss across the control valve. The orifice plate is present to illustrate some type of flowrate measurement, and the flow indicator controller (FIC) illustrates that the measured flowrate is compared to a set point, and deviations from the set point are compensated by adjusting the valve, usually pneumatically. If the flowrate is too large, the valve is partially closed, restricting the flowrate. However, this also increases the frictional pressure loss across the valve, as discussed in Section 19.3.2.

The behavior of the system can be quantified by a *system curve*. The general equation for a chemical process, in terms of pressure, is given by the mechanical energy balance between Points 1 and 2 in Figure 19.21:

$$\Delta P_{\text{pump}} = \Delta P_{12} + \rho g \Delta z_{12} + (-\Delta P_f) + (-\Delta P_{cv}) = (P_2 - P_1) + \rho g(z_2 - z_1) + (-\Delta P_f) + (-\Delta P_{cv}) \quad (19.69)$$

where

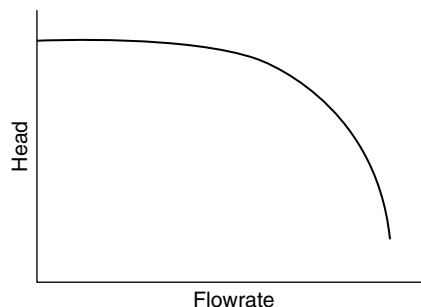

Figure 19.20 Typical Shape of Pump Curve for Centrifugal Pump

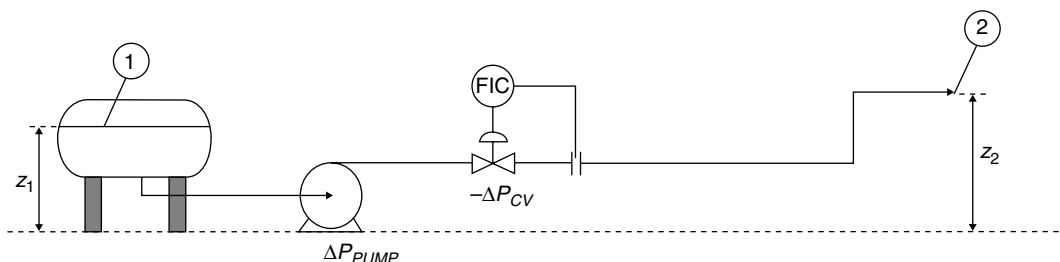

Figure 19.21 Physical Situation for System Curve

$$-\Delta P_{fr} = \rho e_f = \frac{2\rho f L_{eq} u^2}{D} \quad (19.70)$$

Equation (19.70) is derived from the mechanical energy balance with only the pressure and friction terms. It is important to remember that Δ represents out-in; therefore, the frictional loss term and the pressure loss across the valve are negative numbers before the included negative sign. The system curve is the right-hand side of Equation (19.69) without the term for the control valve:

$$\Delta P_{system} = (P_2 - P_1) + \rho g(z_2 - z_1) + (-\Delta P_{fr}) = (P_2 - P_1) + \rho g(z_2 - z_1) + \frac{32\rho f L_{eq} \dot{v}^2}{\pi^2 D^5} \quad (19.71)$$

Equation (19.71) is a parabola, concave upward, on a plot of pressure increase versus flowrate. It is of the form $\Delta P_{system} = a + b\dot{v}^2$, where $a = (P_2 - P_1) + \rho g(z_2 - z_1)$ and $b = 32\rho f L_{eq} / (\pi^2 D^5)$. Since the manufacturer pump curve is usually provided in head units, Equation (19.69) can be rewritten in head units as

$$h_{system} = \frac{\Delta P_{system}}{\rho g} = \frac{(P_2 - P_1)}{\rho g} + (z_2 - z_1) + \frac{32 f L_{eq} \dot{v}^2}{g \pi^2 D^5} \quad (19.72)$$

Figure 19.22 illustrates the result if the pump curve and the system curve are plotted on the same graph. The indicated pressure changes demonstrate how the head provided by the pump must equal the desired head increase from source to destination, plus the frictional pressure loss, plus the pressure loss across the control valve, as quantified in Equation (19.69). The process of flowrate regulation is also illustrated in Figure 19.22. If the flowrate is to be reduced, the valve is closed, and the operating point moves to the left. At this lower flowrate, the frictional losses are lower, but the pressure loss across the valve is larger. The opposite is true for a higher flowrate. At the intersection of the two curves, the valve is wide open, and the maximum possible flowrate has been reached. This analysis assumes that the pump is operating at constant speed. For a variable speed pump, the pump curve moves up or down as the speed of rotation of the impeller changes. (Note that this simplified explanation omits the very small pressure drop across a wide-open control valve.) Operation to the right of this point is impossible. It is important not to confuse the meanings of the intersection points on the pump-system curve plot and the NPSH plot.

The pump and system curve plot also illustrates the cost of flowrate regulation. The pump must provide sufficient pressure to overcome the losses across the valve over a wide range of flowrates. Additional pump power is required for the possibility of operating at lower flowrates with a very large pressure drop across the valve. In general, this is a small cost for a pump, because the liquid density is high. Variable speed pumps are also available with different pump curves for different speeds. For these, the flowrate is regulated by the rotation speed of the impeller, not by a valve. It is not usually worth the extra cost for small pumps given the low cost of pumping liquids but may be worth considering for larger pumps and flowrates. Pumps with different impeller sizes have different pump curves for each impeller size. However, changing an impeller is not something that can be done while a process is operating.

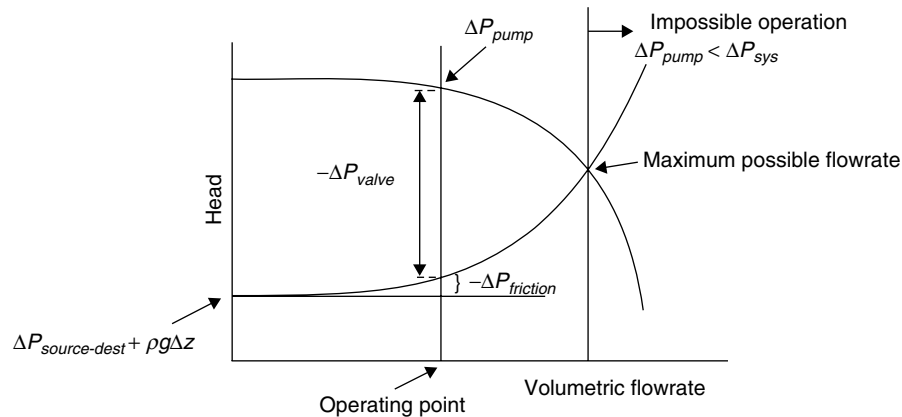

Figure 19.22 Pump (Constant Speed Centrifugal Pump) and System Curve Components

Pumps (and compressors) are about the only pieces of equipment in a chemical plant with moving parts. Moving parts can fail. Therefore, since pumps are often inexpensive (on the order of \$10,000), a backup pump is typically installed in parallel so the plant can continue operating while the primary pump is maintained. Since shutdown and start-up can take days, it makes sense not to shut down a process that generates profit at a rate of thousands of dollars per minute to avoid purchasing a relatively inexpensive backup pump.

The presence of a backup pump can also be exploited if it is necessary to scale-up a process. The piping system can be constructed such that the two pumps can operate simultaneously, either in series or in parallel. If the pumps are in series, the head increase doubles at the same flowrate. If the pumps are in parallel, the flowrate doubles at the same head increase. The pump curves for these situations are illustrated in Figure 19.23. The two system curves illustrate the maximum possible scale-up for two different system curves, indicated by the dots. In one case, the parallel configuration provides more scale-up potential, and in the other case, the series configuration provides more scale-up potential. This demonstrates that it is not possible to make any generalizations about which configuration can produce more scale-up. It all depends on the particular system.

Positive-displacement pumps perform differently from centrifugal pumps. They are usually used to produce higher pressure increases than are obtained with centrifugal pumps. The performance characteristics are represented on Figure 19.24(a), and these are sometimes referred to as **constant-volume pumps**. It can be observed that the flowrate through the pump is almost constant over a wide range of pressure increases, which makes flowrate control using the pressure increase impractical. One method to regulate the flow through a positive-displacement pump is illustrated in Figure 19.24(b). The strategy is to maintain constant flowrate through the pump. By regulating the flow of the recycle stream to maintain constant flowrate through the pump, the downstream flowrate can be regulated independently of the flow through the pump. Therefore, if a higher flow to the process is needed, then the bypass control valve is closed, and vice versa.

It is observed from Figure 19.21 and Figure 19.24 that, in both cases, flowrate regulation occurs by adjusting a valve. For regulation of temperature, a valve on a cooling or heating fluid is adjusted. For regulation of concentration, valves on mixing streams are adjusted. This emphasizes the concept that about the only way to regulate anything in a chemical process is to adjust a valve position.

Process conditions are usually regulated or modified by adjusting valve settings in the plant.

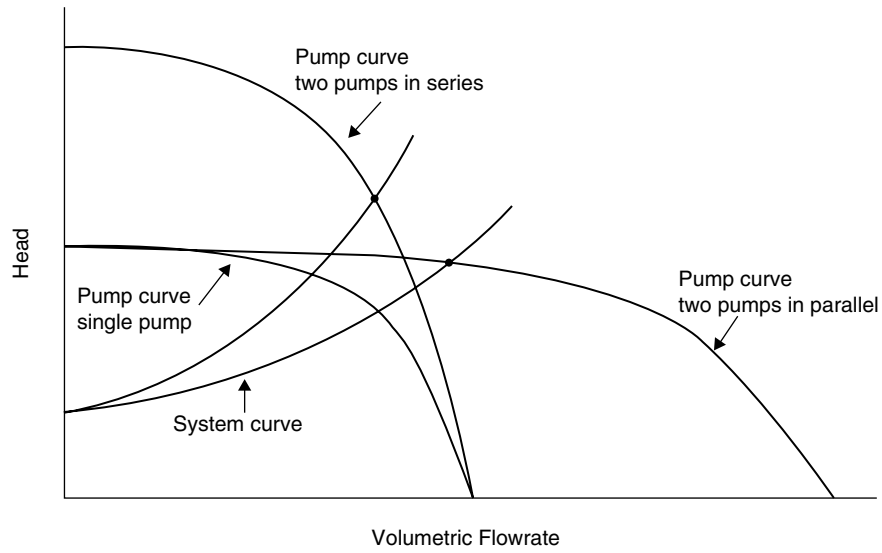

Figure 19.23 Pump and System Curves for Series and Parallel Pumps

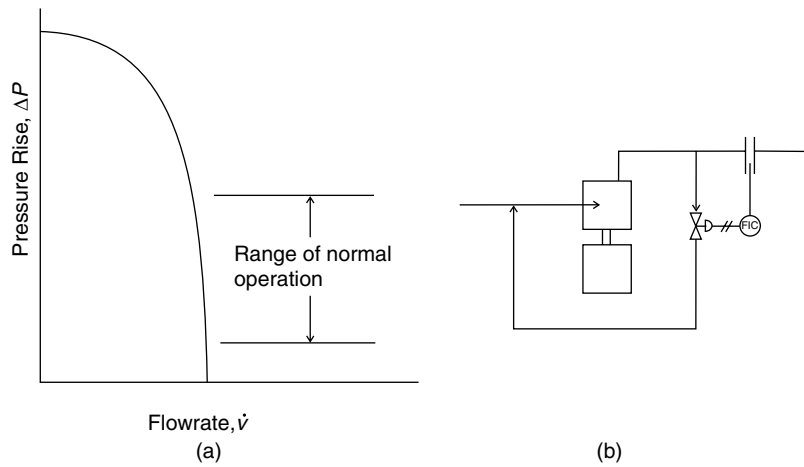

Figure 19.24 (a) Typical Pump Curve for Positive-Displacement Pump and (b) Method for Flowrate Regulation

Example 19.18

Develop the system curve for flow of water at approximately 10 kg/s through 100 m of 2-in, schedule-40, commercial-steel pipe with the source and destination at the same height and both at atmospheric pressure.

Solution

The density of water will be taken as 1000 kg/m^3 , and the viscosity of water will be taken as 1 mPa s (0.001 kg/m s). The inside diameter of the pipe is 0.0525 m . The Reynolds number can be determined to be 2.42×10^5 . For a roughness factor of 0.001 , $f = 0.005$. Equation (19.71) reduces to

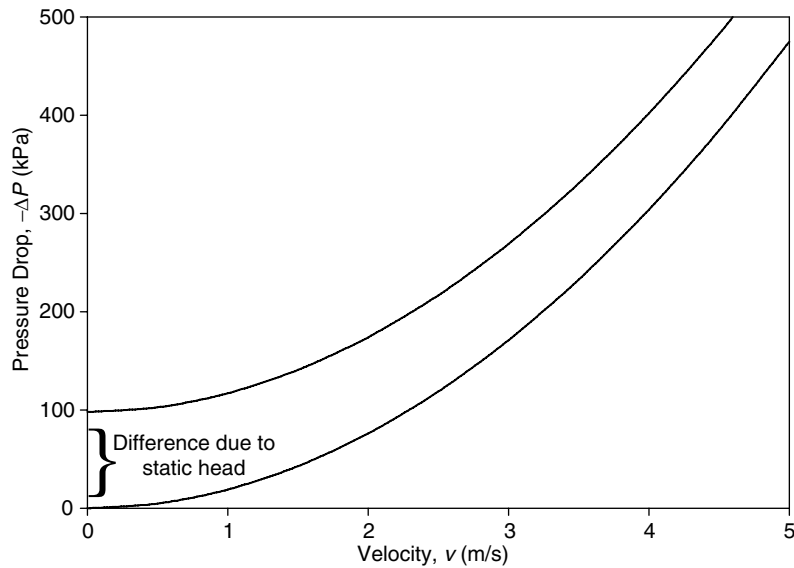

Figure E19.18 System Curves for Examples 19.18 and 19.19

$$\Delta P = -19u^2 \quad (\text{E19.18a})$$

since ΔP_{1-3} is zero, with ΔP in kPa and u in m/s. This is the equation of a parabola, and it is plotted in Figure E19.18. Therefore, from either the equation or the graph, the frictional pressure drop is known for any velocity.

Example 19.19

Repeat Example 19.18 for the same length of pipe but with a 10 m vertical elevation change, with the flow from lower to higher elevation, but with the source and destination both still at atmospheric pressure.

Solution

Here, the potential energy term from the mechanical energy balance must be included. The magnitude of this term is 10 m of water, so $\rho g \Delta z = 98$ kPa. Equation (19.69) reduces to

$$\Delta P = -(98 + 19u^2) \quad (\text{E19.19})$$

with ΔP in kPa and u in m/s. This equation is also plotted in Figure E19.18. It is observed that the system curve has the same shape as that in Example 19.18. This means that the frictional component is unchanged. The difference is that the entire curve is shifted up by the constant, static pressure difference.

Example 19.20

The centrifugal pump shown in Figure E19.20 is used to supply water to a storage tank. The pump inlet is at atmospheric pressure, and water is pumped up to the storage tank, which is open to atmosphere, via large-diameter pipes. Because the pipe diameters are large, the frictional losses in the pipes and any change in fluid velocity can be safely ignored.

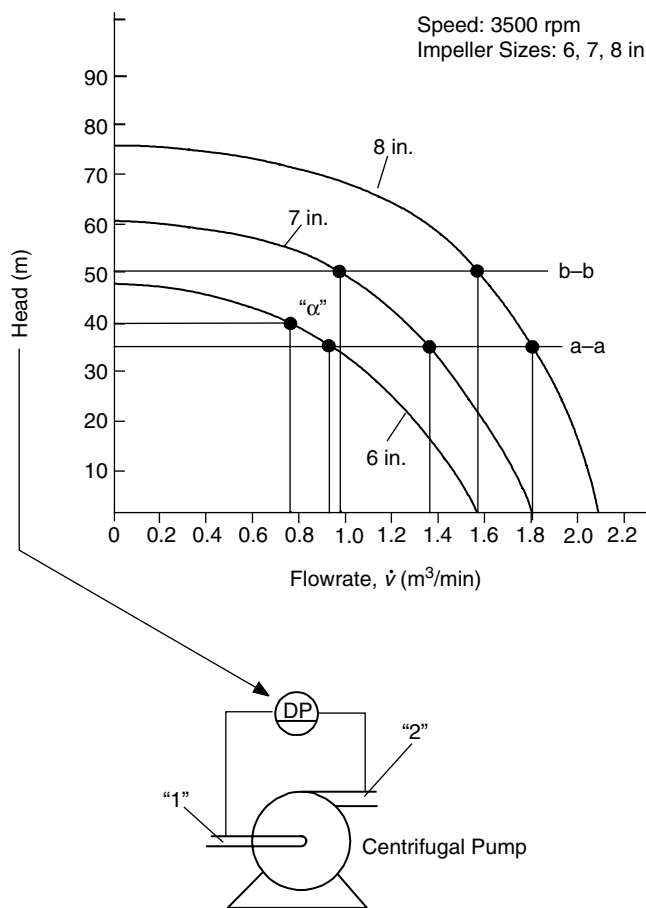

Figure E19.20 Illustration of Example 19.20

- If the storage tank is located at an elevation of 35 m above the pump, predict the flow using each impeller.
- If the storage tank is located at an elevation of 50 m above the pump, predict the flow using each impeller.

Solution

- Figure E19.20 shows the pump curves for three different impeller sizes for the same pump. From Figure E19.20, at $\Delta h_p = 35$ m (see line a-a):
 - 6- in Impeller: Flow = $0.93 \text{ m}^3/\text{min}$
 - 7- in Impeller: Flow = $1.38 \text{ m}^3/\text{min}$
 - 8- in Impeller: Flow = $1.81 \text{ m}^3/\text{min}$
 Therefore, each impeller can be used, and the larger impeller provides a larger flowrate.
- From Figure E19.20, at $\Delta h_p = 50$ m (see line b-b):
 - 6- in Impeller: Flow = $0 \text{ m}^3/\text{min}$
 - 7- in Impeller: Flow = $0.99 \text{ m}^3/\text{min}$
 - 8- in Impeller: Flow = $1.58 \text{ m}^3/\text{min}$

In this case, the 6-in impeller is not sufficient to provide the desired flowrate, so only the 7-in and 8-in impellers are appropriate choices.

$$-\Delta h_p = 50 \text{ m} = (P_1 - P_2)/\rho g = P_1/\rho g - 1.2 \times 10^5 / [750(9.81)] = P_1/\rho g - 16.3 \text{ m}$$

$$P_1 = (50 + 16.3)\rho g = 66.3(750)(9.81) = 4.88 \times 10^5 \text{ Pa} = 4.88 \text{ bar}$$

19.5.4 Compressors

19.5.4.1 Compressor Curves

The performance of centrifugal compressors is somewhat analogous to that of centrifugal pumps. A characteristic performance curve, supplied by the manufacturer, defines how the outlet pressure varies with flowrate. However, compressor behavior is far more complex than that for pumps because the fluid is compressible.

Figure 19.25 shows the performance curves for a centrifugal compressor. It is immediately observed that the y-axis is the ratio of the outlet pressure to inlet pressure. This is in contrast to pump curves, which have the difference between these two values on the y-axis. Curves for two different rotation speeds are shown. As with pump curves, curves for power and efficiency are often included but are not shown here. Unlike most pumps, the speed is often varied continuously to control the flowrate because the higher power required in a compressor makes it economical to avoid throttling the outlet as in a centrifugal pump.

Centrifugal compressor curves are read just like pump curves. At a given flowrate and revolutions per minute, there is one pressure ratio. The pressure ratio decreases as flowrate increases. A unique feature of compressor behavior occurs at low flowrates. It is observed that the pressure ratio increases with decreasing flowrate, reaches a maximum, and then decreases with decreasing flowrate. The locus of maxima is called the **surge line**. For safety reasons, compressors are operated to the right of the surge line. The surge line is significant for the following

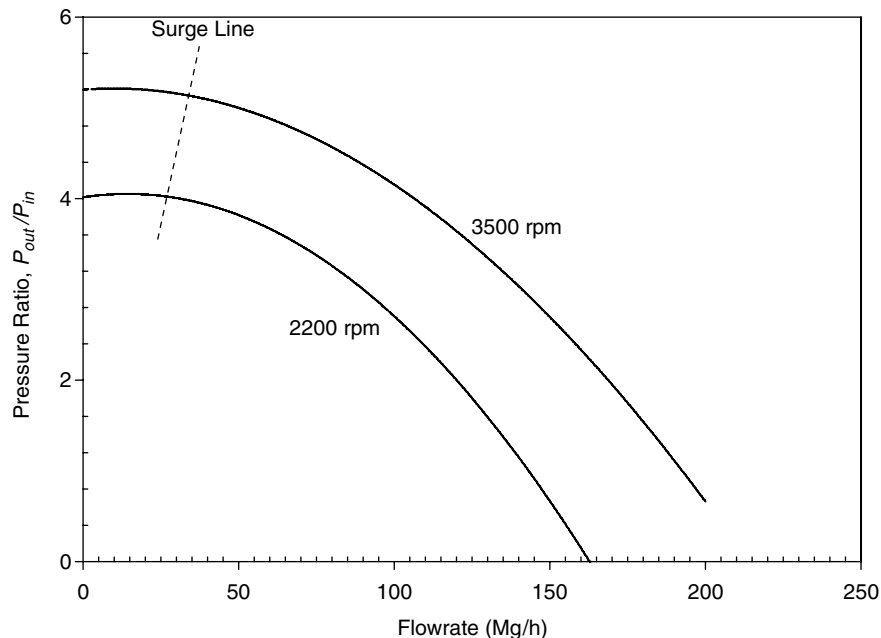

Figure 19.25 Performance Curves for a Centrifugal Compressor

reason. Imagine the compressor is operating at a high flowrate and the flowrate is lowered continuously, causing a higher outlet pressure. At some point, the surge line is crossed, lowering the pressure ratio. This means that downstream fluid is at a higher pressure than upstream fluid, causing a backflow. These flow irregularities can severely damage the compressor mechanism, even causing the compressor to vibrate or surge (hence the origin of the term). Severe surging has been known to cause compressors to become detached from the supports keeping them stationary and literally to fly apart, causing great damage. Therefore, the surge line is considered a limiting operating condition below which operation is prohibited. Surge control on compressors is usually achieved by opening a bypass valve on a line connecting the outlet to the inlet of the compressor. When the surge point is approached, the bypass valve is opened, and gas flows from the outlet to the inlet, thereby increasing the flow through the compressor and moving it away from the surge condition.

Positive-displacement compressors also exist and are used to compress low volumes to high pressures. Centrifugal compressors are used to compress higher volumes to moderate pressures and are often staged to obtain higher pressures. Figure 19.5 illustrates the inner workings of a compressor.

19.5.4.2 Compressor Staging

There are two limiting cases for compressor behavior: isothermal and isentropic. An actual compressor is neither isothermal nor isentropic; however, the behavior lies between these two limiting cases. From the general mechanical energy balance, compressor work is

$$\eta_c W_s = \int_{P_1}^{P_2} \frac{dP}{\rho} \quad (19.73)$$

where subscripts 1 and 2 denote compressor inlet and outlet, respectively. For the isothermal case, assuming ideal gas behavior (which will fail as the pressure increases but is sufficient to illustrate the basic concepts),

$$\eta_c W_{s, \text{isoth}} = \int_{P_1}^{P_2} \frac{dP}{\rho} = \frac{RT}{M} \int_{P_1}^{P_2} \frac{dP}{\rho} = \frac{RT}{M} \ln \left(\frac{P_2}{P_1} \right) \quad (19.74)$$

For isentropic compression, the relationship from thermodynamics for adiabatic, reversible, compression is

$$PV^\gamma = \frac{P}{\rho^\gamma} = \text{constant} \quad (19.75)$$

where $\gamma = C_p/C_v$, the ratio of the constant pressure and constant volume heat capacities. Using the compressor inlet as a reference point,

$$\frac{P_1}{\rho_1^\gamma} = \frac{P}{\rho^\gamma} \quad (19.76)$$

Solving Equation (19.76) for ρ , using that value in Equation (19.73), and integrating yields a well-known expression from thermodynamics for adiabatic, reversible, compression of an ideal gas:

$$\eta_c W_{s, \text{isen}} = \frac{\gamma RT_1}{M(\gamma - 1)} \left[\left(\frac{P_2}{P_1} \right)^{\frac{\gamma - 1}{\gamma}} - 1 \right] \quad (19.77)$$

Taking the ratio of Equations (19.74) and (19.77), and realizing that $T = T_1$ in Equation (19.74), since the temperature is constant at the inlet value in the isothermal case, yields

$$\frac{W_{s,isoth}}{W_{s,isen}} = \frac{\ln\left(\frac{P_2}{P_1}\right)}{\frac{\gamma}{\gamma-1} \left[\left(\frac{P_2}{P_1}\right)^{\frac{\gamma}{\gamma-1}} - 1 \right]} \quad (19.78)$$

Figure 19.26 is a plot of Equation (19.78), with the dependent variable as the compression ratio, P_2/P_1 . Figure 19.26 demonstrates that the reversible, adiabatic work for isothermal compression is always less than that for isentropic compression. As the compression ratio exceeds 3 to 4, the isothermal work is significantly less than the isentropic work, making isothermal compression desirable. Of course, since compressing a gas always increases the gas temperature, isothermal compression cannot be accomplished. However, isothermal compression can be approached by staging compressors with intercooling, as illustrated in Figure 19.27 for a two-stage configuration.

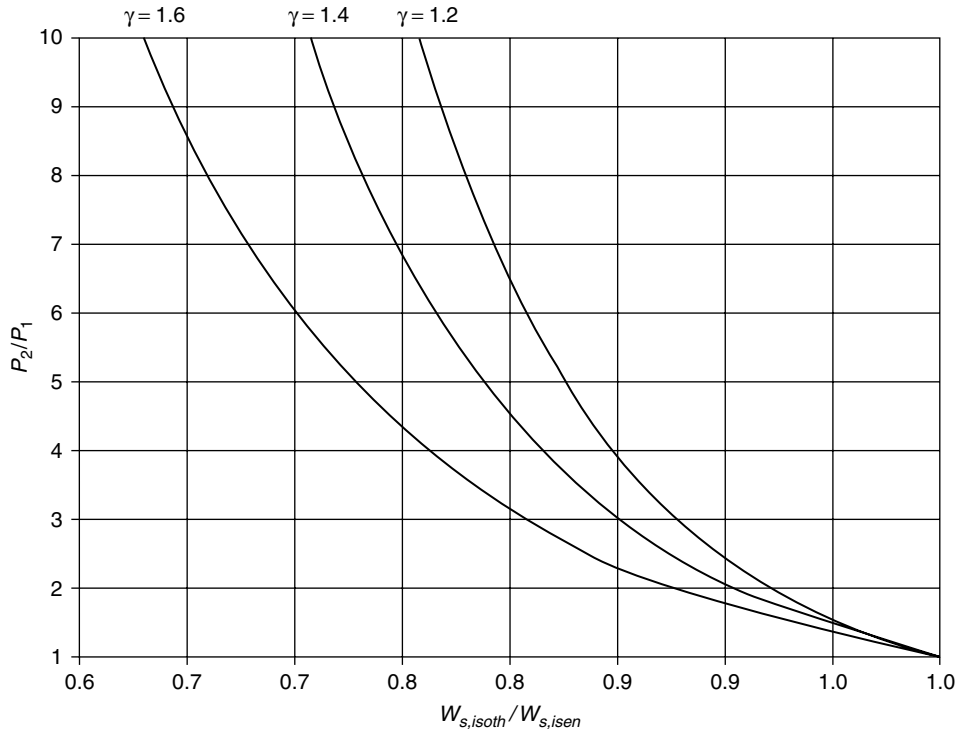

Figure 19.26 Comparison of Isothermal and Isentropic Work for Compressors

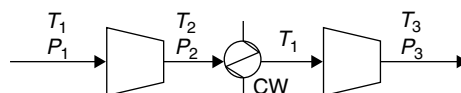

Figure 19.27 Example of Two-Stage Compressor Configuration

Isothermal compression can be reached theoretically with an infinite number of compressors each with an infinitesimal temperature rise, hardly a practical situation. From thermodynamics, it can be shown that the minimum compressor work for staged adiabatic compressors, with interstage cooling to the feed temperature to the first compressor, is accomplished with an equal compression ratio in each compressor stage. This is not necessarily the economic optimum, which would require analysis of the capital cost of the compressor stages and heat exchangers, the operating cost of the compressor, and the utility cost of the cooling medium. However, the preceding analysis explains why compressors are usually staged when the compression ratio exceeds 3 to 4.

19.5.5 Performance of the Feed Section to a Process

A common feature of chemical processes is the mixing of reactant feeds before they enter a reactor. When two streams mix, they are at the same pressure. The consequences of this are illustrated by the following scenario.

Phthalic anhydride can be produced by reacting naphthalene and oxygen. The feed section to a phthalic anhydride process is shown in Figure 19.28. The mixed feed enters a fluidized bed reactor operating at five times the minimum fluidization velocity. A stream table is given in Table 19.4. It is assumed that all frictional pressure losses are associated with equipment and that frictional losses in the piping are negligible. It is temporarily necessary to scale down production by 50%. The engineer must determine how to scale down the process and to determine the new flows and pressures.

It is necessary to have pump and compressor curves in order to do the required calculations. In this example, equations for the pump curves are used. These equations can be obtained by fitting a polynomial to the curves provided by pump manufacturers. As discussed in Section 19.5.3, pump curves are usually expressed as pressure head versus volumetric flowrate so that they can be used for a liquid of any density. In this example, pressure head and volumetric flowrate have been

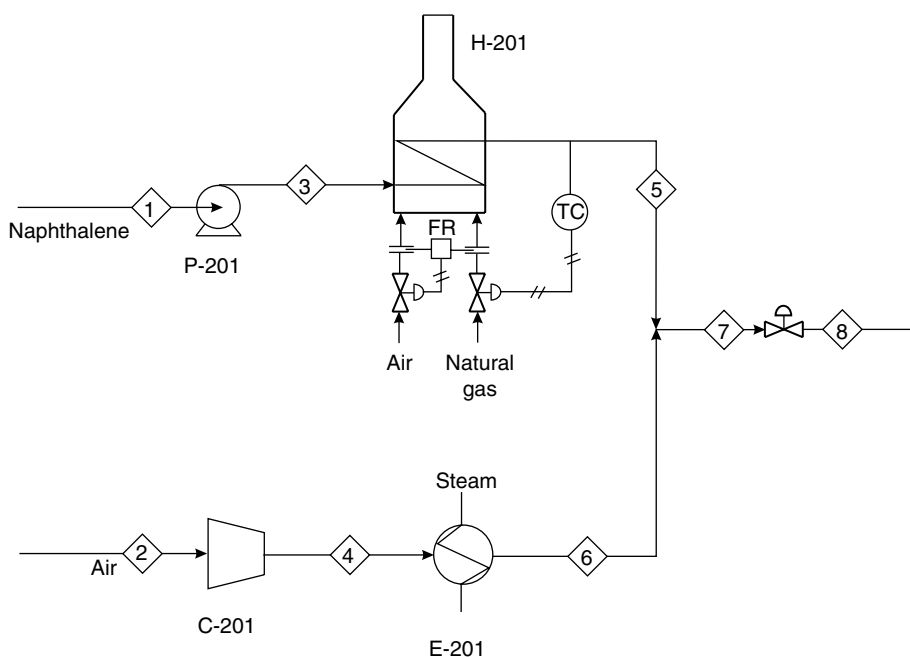

Figure 19.28 Feed Section to Phthalic Anhydride Process

Table 19.4 Partial Stream Table for Feed Section in Figure 19.27

	Stream							
	1	2	3	4	5	6	7	8
P (kPa)	80.00	101.33	343.0	268.0	243.0	243.0	243.0	200.0
Phase	L	V	L	V	V	V	V	V
Naphthalene (Mg/h)	12.82	—	12.82	—	12.82	—	12.82	12.82
Air (Mg/h)	—	151.47	—	151.47	—	151.47	151.47	151.47

converted to absolute pressure and mass flowrate using the density of the fluids involved. Pump P-201 operates at only one speed, and an equation for the pump curve is

$$\Delta P(\text{kPa}) = 500 + 4.663\dot{m} - 1.805\dot{m}^2 \quad \dot{m} \leq 16.00 \text{ Mg/h} \quad (19.79)$$

Compressor C-201 operates at only one speed, and the equation for the compressor curve is

$$\frac{P_{out}}{P_{in}} = 5.201 + 2.662 \times 10^{-3} \dot{m} - 1.358 \times 10^{-4} \dot{m}^2 + 4.506 \times 10^{-8} \dot{m}^3 \quad \dot{m} \leq 200 \text{ Mg/h} \quad (19.80)$$

From Figure 19.27, it is seen that there is only one valve in the feed section, after the mixing point. Therefore, the only way to reduce the production of phthalic anhydride is to close the valve to the point at which the naphthalene feed is reduced by 50%. Example 19.21 illustrates the consequences of reducing the naphthalene feed rate by 50%.

Example 19.21

For a reduction in naphthalene feed by 50%, determine the pressures and flows of all streams after the scale-down.

Solution

Because it is known that the flowrate of naphthalene has been reduced by 50%, the new outlet pressure from P-201 can be calculated from Equation (19.79). The feed pressure remains at 80 kPa. At a naphthalene flow of 6.41 Mg/h, Equation (19.79) gives a pressure increase of 455.73 kPa, so $P_3 = 535.73$ kPa. Because the flowrate has decreased by a factor of 2, the pressure drop in the fired heater decreases by a factor of 4, since $\Delta P \propto L_{eq} \dot{v}^2$. Therefore, $P_5 = 510.73$ kPa. Consequently, the pressure of Stream 6 must be 510.73 kPa. The flowrate of air can now be calculated from the compressor curve equation.

The compressor curve equation has two unknowns: the compressor outlet pressure and the mass flowrate. Therefore, a second equation is needed. The second equation is obtained from a base-case ratio for the pressure drop across the heat exchanger. The two equations are

$$\frac{P_4}{101.33} = 5.201 + 2.662 \times 10^{-3} \dot{m}_{2,new}^2 - 1.358 \times 10^{-4} \dot{m}_{2,new}^2 + 4.506 \times 10^{-8} \dot{m}_{2,new}^2 \quad (E19.21a)$$

$$P_4 - 510.73 = 25 \left(\frac{\dot{m}_{2,new}}{151.47} \right)^2 \quad (E19.21b)$$

The solution is

$$P_4 = 512.84 \text{ kPa}$$

$$\dot{m}_2 = 43.80 \text{ Mg/h}$$

The stream table for the scaled-down case is given in Table E19.21. Although it is not precisely true, for lack of additional information, it has been assumed that the pressure of Stream 8 remains constant.

It is observed that the flowrate of air is reduced by far more than 50% in the scaled-down case. This is because of the combination of the compressor curve and the new pressure of Streams 5 and 6 after the naphthalene flowrate is scaled down by 50%. The total flowrate of Stream 8 is now 50.21 Mg/h, which is 30.6% of the original flowrate to the reactor. Given that the reactor was operating at five times minimum fluidization, the reactor is now in danger of not being fluidized

Table E19.21 Partial Stream Table for Scaled-Down Feed Section in Figure 19.28

	Stream							
	1	2	3	4	5	6	7	8
P (kPa)	80.0	101.33	535.73	512.84	510.73	510.73	510.73	200.00
Phase	L	V	L	V	V	V	V	V
Naphthalene (Mg/h)	6.41	—	6.41	—	6.41	—	6.41	6.41
Air (Mg/h)	—	43.80	—	43.80	—	43.80	43.80	43.80

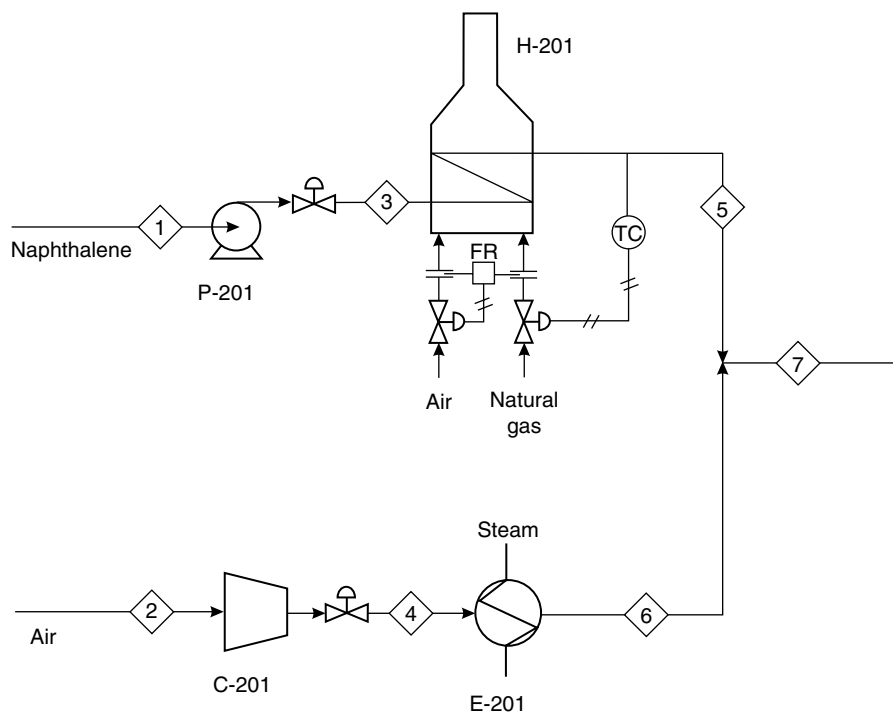

Figure E19.21 Feed Section to Phthalic Anhydride Process with Better Valve Placement Than Shown in Figure 19.28

adequately. Because the phthalic anhydride reaction is very exothermic, a loss of fluidization could result in poor heat transfer, which might result in a runaway reaction. The conclusion is that it is not recommended to operate at these scaled-down conditions.

The question is how the air flowrate can be scaled down by 50% to maintain the same ratio of naphthalene to air as in the original case. The answer is in valve placement. Because of the requirement that the pressures at the mixing point be equal, with only one valve after the mixing point, there is only one possible flowrate of air corresponding to a 50% reduction in naphthalene flow-rate. Effectively, there is no control of the air flowrate. A chemical process would not be designed as in Figure 19.28. The most common design is illustrated in Figure E19.21. With valves in both feed streams, the flowrates of each stream can be controlled independently.

WHAT YOU SHOULD HAVE LEARNED

- How to write the mass balance for pipe flow
- How to apply the mechanical energy balance to pipe flow
- How to apply the force balance to flow around submerged objects
- The types of pipes and pipe sizing
- The types of pumps and compressors and their applicability
- The purpose of including valves in a piping system
- How to design and analyze performance of a system for frictional flow of fluid in pipes
- How to design a system for frictional flow of fluid with submerged objects such as packed and fluidized beds
- Methods for flow measurement
- How to analyze existing fluid flow equipment
- What net positive suction head is and the limitations it places on piping system design
- How to analyze pump and system curves to understand the limitations of pumps
- Why compressors are staged

REFERENCES

1. Geankoplis, C., *Transport Processes and Separation Process Principles*, 4th ed. (Upper Saddle River, NJ: Prentice Hall, 2003), 99–100.
2. Perry, R. H., and D. Green, *Perry's Chemical Engineers' Handbook*, 6th ed. (New York: McGraw-Hill, 1984), Section 5.
3. Couper, J. R., W. R. Penney, J. R. Fair, and S. M. Walas, *Chemical Process Equipment: Selection and Design*, 3rd ed. (New York: Elsevier, 2012), ch. 7.
4. Green, D. W., and R. H. Perry., *Perry's Chemical Engineers' Handbook*, 8th ed. (New York: McGraw-Hill, 2008), Section 10.
5. McCabe, W. L., J. C. Smith, and P. Harriott, *Unit Operations of Chemical Engineering*, 5th ed. (New York: McGraw-Hill, 1993).
6. Bird, R. B., W. E. Stewart, and E. N. Lightfoot, *Transport Phenomena*, 2nd ed. rev. (New York: Wiley, 2006), 51.

7. Pavlov, K. F., P. G. Romankov, and A. A. Noskov, *Problems and Examples for a Course in Basic Operations and Equipment in Chemical Technology* (Moscow: MIR, translated, 1981).
8. Levenspiel, O., *Engineering Flow and Heat Exchange*, 3rd ed. (New York: Springer, 2014), 27.
9. Darby, R., *Chemical Engineering Fluid Mechanics*, 2nd ed. (New York: Marcel Dekker, 2001), 209.
10. Kittredge, C. P., and D. S. Rowley. "Resistance Coefficients for Laminar and Turbulent Flow Through One-Half-Inch Valves and Fittings," *Trans. ASME* 79 (1957): 1759–1766.
11. Haider, A., and O. Levenspiel, "Drag Coefficient and Terminal Velocity of Spheres and Nonspherical Particles," *Powder Technol.* 58 (1989): 63–70.
12. Wen, C. Y., and Y.-H. Yu, "A Generalized Method for Predicting the Minimum Fluidization Velocity," *AIChE J.* 12 (1966): 610–612.
13. Kunii, D., and O. Levenspiel, *Fluidization Engineering*, 2nd ed. (Stoneham, MA: Butterworth-Heinemann, 1991).
14. Miller, R.W., *Flow Measurement Engineering Handbook* (New York: McGraw-Hill, 1983).
15. Cheremisinoff, N. P., and P. N. Cheremisinoff, *Instrumentation for Process Flow Engineering* (Lancaster: Technomic, 1987).
16. Walas, S., *Chemical Process Equipment: Selection and Design* (Stoneham, MA: Butterworth, 1988).

SHORT ANSWER QUESTIONS

1. Explain the physical meaning of each term in the mechanical energy balance.
2. fluid flows from a larger-diameter pipe to a smaller-diameter pipe. How does the velocity change?
3. Explain the concept of pressure head.
4. fluid flows downward in a vertical pipe of uniform diameter. How does the velocity change with position?
5. liquid flows vertically downward through a pipe of uniform diameter at steady state. Explain how the mass flowrate, volumetric flowrate, and velocity change with vertical position.
6. Explain the meaning of the Reynolds number in terms of forces.
7. Sketch the approximate shape of a graph of frictional losses versus Reynolds number. Discuss two other situations in which the graph has similar shape.
8. There are three key parameters that affect frictional loss in pipe flow. State two of them and explain the effect (i.e., whether the parameter increases or decreases, how the frictional loss is affected).
9. For sections of pipes in series, what is the relationship between the mass flowrate in each section? What is the relationship between the pressure drops in each section?
10. For sections of pipes in parallel, what is the relationship between the mass flowrate in each section? What is the relationship between the pressure drops in each section?
11. How is the mechanical energy balance different for compressible flow compared to incompressible flow?
12. What is the difference between form drag and frictional drag?
13. Define void fraction.
14. Explain the difference between void volume, solid volume, and total volume.

15. Define sphericity.
16. When is mercury a better manometer fluid than water or oil? When is mercury not recommended? Assume the specific gravity of mercury is 13.2, and the specific gravity of oil is 0.8.
17. Explain the physical meaning of the intersection of the $NPSH_R$ and $NPSH_A$ curves.
18. Explain the physical meaning of the intersection of the pump and system curves.
19. Why does a compressor cost more to operate than a pump?
20. Why are compressors often staged with intercooling?
21. For fully developed turbulent flow, assuming all variables not mentioned are held constant:
 - a. What is the effect of doubling the flowrate on the pressure drop?
 - b. What is the effect of increasing the pipe diameter by 25% on pressure drop?
 - c. What is the effect of increasing the pipe diameter on flowrate?
 - d. What is the effect of increasing pipe length on pressure drop?
 - e. What is the effect of increasing pipe length on flowrate?
 - f. What is the effect on pressure drop of replacing one long pipe segment with two equal-sized pipe segments of half the length placed in parallel?
22. Repeat Problem 19.21 for laminar flow.

PROBLEMS

23. Consider the situation depicted in Figure P19.23. The fluid is an oil with a specific gravity of 0.85. Fill in the missing data in Table P19.23.

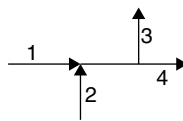

Figure P19.23

Table P19.23

Stream	Pipe	\dot{m} (kg/s)	\dot{v} (m^3/s)	u (m/s)
1	2-in, schedule 40	6		
2	3.5-in, schedule 40		0.0106	
3	1.5-in, schedule 40			4.032
4	3-in, schedule 40			

24. For water flowing in the situation shown in Figure P19.24 and the data in Table P19.24, do the following:
 - a. Calculate the mass flowrate of Stream 3.
 - b. Calculate the velocity of Stream 4.
 - c. What schedule-40 pipe size must be used in Stream 3?

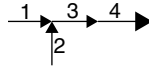

Figure P19.24

Table P19.24

Stream	Pipe	u (m/s)
1	1-in, schedule 40	5
2	1.5-in, schedule 40	3
3	?-in, schedule 40	2.18
4	4-in, schedule 40	?

25. Consider the situation depicted in Figure P19.25. The liquid level in the cylindrical tank is increasing at 0.02 ft/sec.
- What is the **net** rate of flow into the tank?
 - What is the velocity in the 3-in pipe?

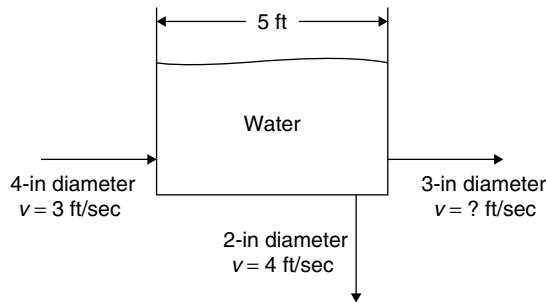

Figure P19.25

- Water is pumped through a 750-ft length of 6-in, schedule-40 pipe. The discharge at the end of the pipe is 50 ft above the suction end. The pump is 80% efficient and is driven by a 20 hp motor. If the friction loss in the pipe is 50 ft l_b/l_b , what is the flowrate through the pipe?
- A hydroelectric power plant takes 25 m^3/s of water from a large reservoir through its turbine and discharges it to the atmosphere at 1 m/s. The turbine is 50 m below the reservoir surface. The frictional head loss in the system is 10 m. The turbine and electric generator as a whole are 80% efficient. Assuming turbulent flow, calculate the power extracted by the turbine.
- Water is pumped at a constant rate of 10 m^3/h from an open tank on the floor to an open tank with a level 10 m above the floor. Frictional losses in the 50-mm-diameter pipe between the tanks are 3.5 J/kg. At what height above the floor must the water level be kept if the pump can develop only 0.1 kW? The pump is 75% efficient.
- Water in a dam on a 75-ft-deep river is passed through a turbine to produce energy. The outlet of the turbine is 15 ft above the river bed. The mass flowrate of water is 65,000 lb/s, and the inside diameter of the discharge pipe is 10 ft. Discharge is to the atmosphere, and frictional losses may be neglected. For a 55% efficient turbine, calculate the power produced.

30. Many potential drugs have low water solubility, hindering their transport in the body's aqueous material distribution medium (blood). One way to improve solubility is to decrease particle size below $1\ \mu\text{m}$ diameter. One method to do this is by high-pressure homogenization, using a homogenizer, which is basically a nozzle. In this process, the drug is dispersed in a solvent and forced through a narrow orifice (nozzle) at high pressure. As the liquid enters the orifice, it experiences a pressure drop so great it partially vaporizes. As it exits the constriction, the vapor bubbles collapse violently and produce local disturbances, breaking up the surrounding solid particles.

A high-pressure homogenizer is being used to decrease the size of some drug particles. The particles are suspended in water at 25°C and sent through the homogenizer at $250\ \text{mL}/\text{min}$. The pressure before the orifice is $34.5\ \text{MPa}$, and the diameter of the pipe is $0.1\ \text{m}$. Determine the diameter orifice (nozzle) that results in an exit pressure at the vapor pressure of water. Neglect friction.

31. A pump operating at 80% efficiency delivers $30\ \text{gal}/\text{min}$ of water from a reservoir to an open-air storage tank at a chemical plant $1\ \text{mi}$ away. A 3-in, schedule-40 pipe is used, and the frictional losses are $200\ \text{ft}\ \text{lb}_f/\text{lb}$. The elevation of the liquid level in the tank is $873\ \text{ft}$ above sea level, and the elevation of the liquid level in the reservoir is $928\ \text{ft}$ above sea level.
- What is the minimum horsepower required for the pump?
 - The elevation of the reservoir is fixed. What elevation of the liquid level of the tank would make the pump unnecessary?
32. A pressurized tank situated above ground level contains a liquid with specific gravity of 0.9. The liquid flows down to ground level through 4-in, schedule-40 pipe through a pump (75% efficiency) and into a tank at a level $25\ \text{m}$ above the level of the source tank at a pressure of $550\ \text{kPa}$ through 2-in, schedule-40 pipe. The pump power is $6.71\ \text{kW}$. A pressure gauge at the pump entrance reads $115.6\ \text{kPa}$, and a pressure gauge at the pump discharge reads $762.6\ \text{kPa}$. The frictional losses in the piping on the suction side of the pump and on the discharge side of the pump are $30\ \text{J}/\text{kg}$ and $50\ \text{J}/\text{kg}$, respectively.
- What is the mass flowrate of liquid through the system?
 - What is the velocity in the 2-in, schedule-40 pipe?
 - What is the pressure of the liquid in the source tank?
 - Determine whether the kinetic energy contribution to the mechanical energy balance is small.
33. Water is pumped from one storage tank to a higher tank at a steady rate of $10^{-3}\ \text{m}^3/\text{s}$. The difference in the elevations of the two water tanks is $50\ \text{m}$. The storage tank, which serves a source, is open to the atmosphere, while the tank receiving the water has a pressure of $170.3\ \text{kPa}$. Pressure gauges in the pipeline at the inlet and outlet of the pump read $34.5\ \text{kPa}$ and $551.6\ \text{kPa}$, respectively. The power supplied by an electric motor to the pump shaft is $1000\ \text{W}$. All piping is 1-in, schedule-40 steel pipe. Find the pump efficiency and friction loss in the pipe per kg of water.
34. Oil ($\text{SG} = 0.88$) flows at $5\ \text{ft}^3/\text{s}$ from one tank, through a pump, to another tank. The pipe diameter between the source tank and the pump is 12 in, and the pipe diameter between the pump and the destination tank is 6 in. The liquid level in the source tank is 10 ft above the pump, which is at ground level. The liquid level in the destination tank is 12 ft. The source tank is at 25 psia, and the destination tank is open to the atmosphere. A manometer is connected to the upstream and downstream pipes, immediately adjacent to the pump, with a differential height of 36 in of mercury. The pump is 75% efficient. Frictional losses may be neglected.

- a. What is the power rating of the pump?
 - b. What is the maximum possible height of the bottom of the destination tank?
35. A fluid with specific gravity of 0.8 is in a tank, at a pressure of 150 kPa, with a level maintained at 5 m above ground level. The fluid leaves the tank through 4-in, schedule-40 pipe (frictional loss of 30 J/kg) at a mass flowrate of 6.5 kg/s and enters a pump at ground level. The pump power is 1.5 kW and is 70% efficient. The fluid leaving the pump flows through 3.5-in, schedule-40 pipe (frictional loss of 50 J/kg) to a “final” point in the pipe above the original tank level, where the pressure is 200 kPa.
- a. Find the velocity at the final point in the pipe.
 - b. Determine the pressure at the pump inlet.
 - c. Determine the height above the ground of the final point in the pipe.
36. Consider the problem of how long it takes for a tank to drain. Consider an open-top cylindrical tank with one horizontal exit pipe at the bottom of the tank that discharges to the atmosphere. The tank has a diameter, d , and the height of liquid in the tank at any time is h .
- a. The mass balance is unsteady state. Explain why the mass balance is

$$\frac{dm}{dt} = -\dot{m}_{out}$$

where m is the mass of liquid in the tank and \dot{m}_{out} is the mass flowrate out of the tank.

- b. The mass in the tank is the fluid density times the volume of liquid in the tank. The flowrate, \dot{m}_{out} , can be related to the velocity and the cross-sectional area of the exit pipe based on what we have already learned. The volume of liquid in the tank can be related to the height of liquid in the tank. Simplify the differential mass balance to obtain an expression for the height of liquid in the tank as a function of the velocity of the liquid through the exit pipe.
 - c. Now, write a mechanical energy balance on the fluid in the tank and pipe from the top level in the tank to the pipe outlet, neglecting friction. It is generally assumed the velocity of the tank level (i.e., the fluid level in the tank) is small because of the large diameter. Solve for the velocity, and rearrange the differential equation to look like
- $$\frac{dh}{dt} = af(h)$$
- where a is a group of constants and $f(h)$ is a function of the height that you have derived.
- d. Solve this differential equation for height as a function of time with the initial condition of a height of h_0 at time zero.
 - e. Rearrange the answer to Part (d) to get an expression for the time for complete drainage.
37. The following equations describe a fluid-flow system. Draw and label the system.

$$\begin{aligned} \dot{m}_1 + \dot{m}_2 &= \dot{m}_3 = \dot{m}_4 \\ \frac{P_4 - P_3}{\rho} + \frac{v_4^2 - v_3^2}{2} - \eta W_s &= 0 \\ \frac{P_5 - P_4}{\rho} - \frac{v_4^2}{2} + g(z_5 - z_4) + e_f &= 0 \end{aligned}$$

38. The following equations describe a fluid flow system, with friction neglected. Draw and label the system, making sure that your diagram is visually accurate.

$$\begin{aligned} \dot{m}_3 + \dot{m}_2 &= \dot{m}_4 = \dot{m}_5 \\ \frac{P_2 - P_1}{\rho} + g(z_2 - z_1) + \frac{v_2^2}{2} &= 0 \\ g(z_6 - z_1) - \eta W_s &= 0 \\ \frac{P_5 - P_4}{\rho} + \frac{v_5^2 - v_4^2}{2} - \eta W_s &= 0 \\ \frac{P_6 - P_5}{\rho} + g(z_6 - z_5) - \frac{v_5^2}{2} &= 0 \\ z_6 &> z_1 \end{aligned}$$

39. An aneurysm is a weakening of the walls of an artery causing a ballooning of the arterial wall. The result is a region of larger diameter than a normal artery. If the “balloon” ruptures in a high-blood-flow area, such as the aorta, death is almost instantaneous. Fortunately, there are often symptoms due to slow leakage that can precede rupture. What happens to the blood velocity as it passes through the aneurysm? Justify your answer using equations. In the human body, very small changes in pressure can be significant. Using the mechanical energy balance, neglecting only friction and potential energy effects, analyze the pressure change as blood enters the aneurysm a large distance from the heart, so that the pulse flow is not an issue. The blood is flowing in a region not in the vicinity of the heart. What is the effect of the observed pressure change?
40. A pipeline is replaced by new 2-in, schedule-40, commercial-steel pipe. What power would be required to pump water at a rate of 100 gpm through 6000 ft of this pipe?
41. Hot water at 43°C flows from a constant-level tank through 2-in, schedule-40, commercial-steel pipe, from which it emerges 12.2 m below the level in the tank. The equivalent length of the piping system is 45.1 m. Calculate the rate of flow in m³/s.
42. Crude oil ($\mu = 40$ cP, SG = 0.87) is to be pumped from a storage tank to a refinery through a series of pump stations via 10-in, schedule-20, commercial-steel pipeline at a flowrate of 2000 gpm. The pipeline is 50 mi long and contains 35 90° elbows and 10 open gate valves. The pipeline exit is 150 ft higher than the entrance, and the exit pressure is 25 psig. What horsepower is required to drive the pumps if they are 70% efficient?
43. A pipeline to carry 1 million bbl/day of crude oil (1 bbl = 42 gal, SG = 0.9, $\mu = 25$ cP) is constructed with 50-in-inside-diameter, commercial-steel pipe and is 700 mi long. The source and destination are at atmospheric pressure and the same elevation. There are 50 wide-open gate valves, 25 half-open globe valves, and 50 45° elbows. There will be 25 identical pumps along this pipeline, each with an efficiency of 70%. What is the power required for each pump?
44. A pump draws a solution of specific gravity 1.2 with the viscosity of water from a ground-level storage tank at 50 psia through 3.5-in, schedule-40, commercial-steel pipe at a rate of 12 lb/s. The pump produces 4.5 hp with an efficiency of 75%. The pump discharges through a 2.5-in, schedule-40 commercial steel pipe to an overhead tank at 100 psia, which is 50 ft above the level of solution in the feed tank. The suction line has an equivalent length of 20 ft, including the tank exit. The discharge line contains a half-open globe valve, two wide-open gate valves, and two 90° elbows. What is the maximum total length of discharge piping allowed for this pump to work?
45. Many chemical plants store fuel oil in a “tank farm” on the outskirts of the plant. To prevent an environmental disaster, there are specific rules regarding the design of such facilities. One

such rule is that there be an emergency dump tank with the capacity of the largest storage tank. Should a leak or structural problem occur with a tank, the fuel oil can be pumped into the emergency dump tank.

Consider the design of the pumping system from a 250 m³ tank storing #6 fuel oil into a 250 m³ dump tank. The viscosity of #6 fuel oil is 0.8 kg/m s, and its density is 999.5 kg/m³. The piping system consists of 43 m of commercial-steel pipe, four 90° flanged regular elbows, a sharp entrance, an exit, and a pump. The oil must be pumped to an elevation 3.35 m above the exit point from the source tank.

- a. If 20-in, schedule-40, commercial-steel pipe is used, and if it is necessary to accomplish the transfer within 45 min, determine the power rating required of the pump. Assume the pump is 80% efficient.
 - b. If the pump to be used has 10 kW at 80% efficiency, and the pipe is 20-in, schedule-40, commercial-steel pipe, determine how long the transfer will take.
 - c. If the pump to be used has 20 kW at 80% efficiency, and the transfer is to be accomplished in 45 min, determine the required schedule-40 pipe size.
46. Two parallel sections of pipe branch from the same split point. Both branches end at the same pressure and the same elevation. Branch 1 is 3-in, schedule-40, commercial-steel pipe and has an equivalent length of 12 m. Branch 2 is 2-in, schedule-80, commercial-steel pipe and has an equivalent length of 9 m.
- a. Assuming fully turbulent flow, what is the split ratio between the two branches?
 - b. Suppose that Branch 2 ends 5 m higher than Branch 1. What is the split ratio between the branches in this case?
47. Consider a two-pipes-in-series system: that is, Pipe 1 is followed by Pipe 2. The liquid is water at room temperature with a mass flowrate of 2 kg/s. The pipes are horizontal. Calculate the pressure drop across these two pipes and the power necessary to overcome the frictional loss. Ignore the minor losses due to the pipe fitting. The pipe data are

Pipe	L (m)	Pipe Size	Material
1	10	1-in, schedule-40	Commercial steel
2	15	2-in, schedule-40	Cast iron

48. Assume that the same two pipes in Problem 19.47 are now in parallel with the same total pressure drop. Compute the mass flowrate in each section of pipe. Neglect additional frictional losses due to the parallel piping. Explain the reason for the observed split between the parallel pipes.
49. A pipe system to pump #6 fuel oil ($\mu = 0.8$ kg/m s, $\rho = 999.5$ kg/m³) consists of 50 m of 8-in, schedule-40, commercial-steel pipe. It has been observed that the pressure drop is 8.79×10^4 Pa.
- a. Determine the volumetric flowrate of the fuel oil.
 - b. Extra capacity is needed. Therefore, it has been decided to add a parallel line of the same length (neglect minor losses) using 5-in, schedule-40, commercial-steel pipe. By what factor will the fuel oil volumetric flowrate increase?
50. There are three equal-length sections of identical 3-in, schedule-40, commercial-steel pipe in series. An increased flowrate of 20% is needed. How is the pressure drop affected? It is decided to replace the second section with two equal-length, identical sections of the original pipe in parallel. How is the pressure drop in this system affected relative to the original case? Neglect minor losses due to elbows and fittings and assume fully developed turbulent flow.

51. Consider two parallel arteries of the same length, both fed by a main artery. The flowrate in the main artery is $10^{-6} \text{ m}^3/\text{s}$. One branch is stenotic (has plaque build-up due to too many Big Macs, Double Whoppers, etc.). The stenotic artery will be modeled as a rigid pipe with 60% the diameter of the healthy artery (diameter of 0.1 cm). For this problem, blood may be considered to be a Newtonian fluid with the properties of water. What fraction of the blood flows in each arterial branch? Be sure to validate any assumptions made.
52. One of the potential benefits of the production of shale gas is that certain seams of the gas contain significant amounts of ethane, which can be cracked into ethylene, a building block for many other common chemicals (polyethylene, ethylene oxide, which is made into ethylene glycol among many others, and tetrafluoroethylene, the monomer for Teflon). Assume that a cracker plant produces ethylene (C_2H_4) at 5 atm and 70°F. It is to be delivered by pipeline to a neighboring plant, which was built near the ethylene cracker facility, which is 10 miles away. The pressure at the neighboring plant entrance must be 2.5 atm. It has been suggested that 6-in, schedule-40, commercial-steel pipe be used. What delivery mass flowrate is possible with this pipe size? If you need to make an assumption, do so and prove its validity.
53. Natural gas (methane, $\mu = 10^{-5} \text{ kg/m s}$) must flow in a pipeline between compression stations. The compressor inlet pressure is 250 kPa, and its outlet pressure is 1000 kPa. Assume isothermal flow at 25°C. The pipe is 6-in, schedule-40, commercial steel. The mass flowrate is 2 kg/s. What is the required distance between pumping stations?
54. Your plant produces ethylene at 6 atm and 60°F. It is to be delivered to a neighboring plant 5 miles away via pipeline, and the pressure at the neighboring plant entrance must be 2 atm. The contracted delivery flowrate is 2 lb/sec. It has been suggested that 4-in, schedule-40, commercial-steel pipe be used. Evaluate this suggestion. Be sure to validate any assumptions made.
55. Calculate the terminal velocity of a 2 mm diameter lead sphere ($\text{SG} = 11.3$) dropped in air. The properties of air are $\rho = 1.22 \text{ kg/m}^3$ and $\mu = 1.81 \times 10^{-5} \text{ kg/m s}$.
56. A packed bed is composed of crushed rock with a density of 200 lb/ft³ with an assumed particle diameter of 0.15 in. The bed is 8 ft deep, has a porosity of 0.3, and is covered by a 3 ft layer of water that drains by gravity through the bed. Calculate the velocity of water through the bed, assuming the water enters and exits at 1 atm pressure.
57. A hollow steel sphere, 5 mm in diameter with a mass of 0.05 g, is released in a column of liquid and attains an upward terminal velocity of 0.005 m/s. The liquid density is 900 kg/m³, and the sphere is far enough from the container walls so that their effect may be neglected. Determine the viscosity of the liquid in kg/m s. Hint: Assume Stokes flow and confirm the assumption with your answer.
58. In a particular sedimentation vessel, small particles ($\text{SG} = 1.1$) are settling in water at 25°C. The particles have a diameter of 0.1 mm. What is the terminal velocity of the particles? Validate any assumptions made.
59. At West Virginia University, each Halloween, there is a pumpkin-drop contest. College, high-school, and middle-school students participate. The goal is to drop a pumpkin off the top of the main engineering building (assume about 100 ft) and have it land close to a target without being damaged. Packing and parachutes are commonly used. You have a theory that the terminal velocity at which a pumpkin packed in your newly invented, proprietary bubble wrap can hit the ground and remain intact is 50 m/s. You will use no parachute, and the shape will be approximately spherical. The pumpkin plus wrapping has a diameter of 40 cm. By calculating the actual terminal velocity, determine whether the pumpkin will exceed the desired terminal velocity. Assume that the wrapped pumpkin has the specific gravity of water, and assume the air is at 25°C and 1 atm.
60. Air enters and passes up through a packed bed of solids 1 m in height. Using the data provided, what are the pressure drop and the outlet pressure?

Data:

$v_s = 1\text{ m/s}$	$P_{inlet} = 0.2\text{ MPa}$
$T = 293\text{ K}$	$\mu = 1.8 \times 10^{-5}\text{ kg/m}\cdot\text{s}$
$D_p = 1\text{ mm}$	$\varepsilon = 0.4$
$\rho_s = 9500\text{ kg/m}^3$	

61. In the regeneration of a packed bed of ion-exchange resin, hydrochloric acid ($SG = 1.2$, $\mu = 0.002\text{ kg/m}\cdot\text{s}$) flows upward through a bed of resin particles (particle density of 2500 kg/m^3). The bed is 40 cm in diameter, and the particles are spherical with a diameter of 2 mm and a bed void fraction of 0.4. The bed is 2 m deep, and the bottom of the bed is 2 m off the ground. The acid is pumped at a rate of $2 \times 10^{-5}\text{ m}^3/\text{s}$ from an atmospheric pressure, ground-level storage tank through the packed bed and into another atmospheric pressure, ground-level storage tank, in which the filled height is 2 m. The complete piping system consists of 75 equivalent meters of 4-in, schedule-40, commercial-steel pipe.
 - a. Determine the required power of a 75% efficient pump for this duty. Remember that a pump must be sized for the maximum duty needed.
 - b. What do you learn from the numbers in Part (a) regarding the relative magnitudes of the maximum duty and the steady-state duty?
 - c. What is the pressure rise needed for the pump?
62. A gravity filter is made from a bed of granular particles assumed to be spherical. The bed porosity is 0.40. The bed has a diameter of 0.3 m and is 1.75 m deep. The volumetric flowrate of water at 25°C through the bed is $0.006\text{ m}^3/\text{s}$. What particle diameter is required to obtain this flowrate?
63. Calculate the flowrate of air at standard conditions required to fluidize a bed of sand ($SG = 2.4$) if the air exits the bed at 1 atm and 70°F . The sand grains have an equivalent diameter of $300\ \mu\text{m}$, and the bed is 3 ft in diameter and 1.5 ft deep, with a porosity of 0.33.
64. Consider a catalyst, specific gravity 1.75, in a bed with air flowing upward through it at 650 K and an average pressure of 1.8 atm ($\mu_{air} = 3 \times 10^{-5}\text{ kg/m}\cdot\text{s}$). The catalyst is spherical with a diameter of 0.175 mm. The static void fraction is 0.55, and the void fraction at minimum fluidization is 0.56. The slumped bed height is 3.0 m, and the fluidized bed height is 3.1 m.
 - a. Calculate the minimum fluidization velocity.
 - b. Calculate the pressure drop at minimum fluidization.
 - c. Estimate the pressure drop at one-half of the minimum fluidization velocity assuming incompressible flow.
65. A manometer containing oil with a specific gravity (SG) of 1.28 is connected across an orifice plate in a horizontal pipeline carrying seawater ($SG = 1.1$). If the manometer reading is 16.8 cm, what is the pressure drop across the orifice? What is it in inches of water?
66. Water is flowing downhill in a pipe that is inclined 35° to the horizontal. A mercury manometer is attached to pressure taps 3 in apart. The interface in the downstream manometer leg is 1.25 in higher than the interface in the upstream leg. What is the pressure drop between the two pressure taps?
67. An orifice having a diameter of 1 in is used to measure the flowrate of SAE 10 lube oil ($SG = 0.928$, $\mu = 60\text{ cP}$) in a 2.5-in, schedule-40, commercial-steel pipe at 70°F . The pressure drop across the orifice is measured by a mercury ($SG = 13.6$) manometer, which reads 3 cm.
 - a. Calculate the volumetric flowrate of the oil.
 - b. How much power is required to pump the oil through the orifice (not the pipe, just the orifice)?

68. You must install a centrifugal pump to transfer a volatile liquid from a remote tank to a point in the plant 1000 ft from the tank. To minimize the distance that the power line to the pump must be strung, it is desirable to locate the pump as close as possible to the plant. If the liquid has a vapor pressure of 30 psia, the pressure in the tank is 30 psia, the level in the tank is 40 ft above the pump inlet, and the required pump NPSH is 20 ft, what is the closest that the pump can be located to the plant without the possibility of cavitation? The line is 2-in, schedule-40, commercial steel, the flowrate is 75 gpm, and the fluid properties are $\rho = 45 \text{ lb/ft}^3$ and $\mu = 5 \text{ cP}$.
69. Refer to Figure P19.69. Answer the following questions. Explain each answer.
- At what flowrate is $\text{NPSH}_A = 3.2 \text{ m}$? Comment on the feasibility of operating at this flowrate.

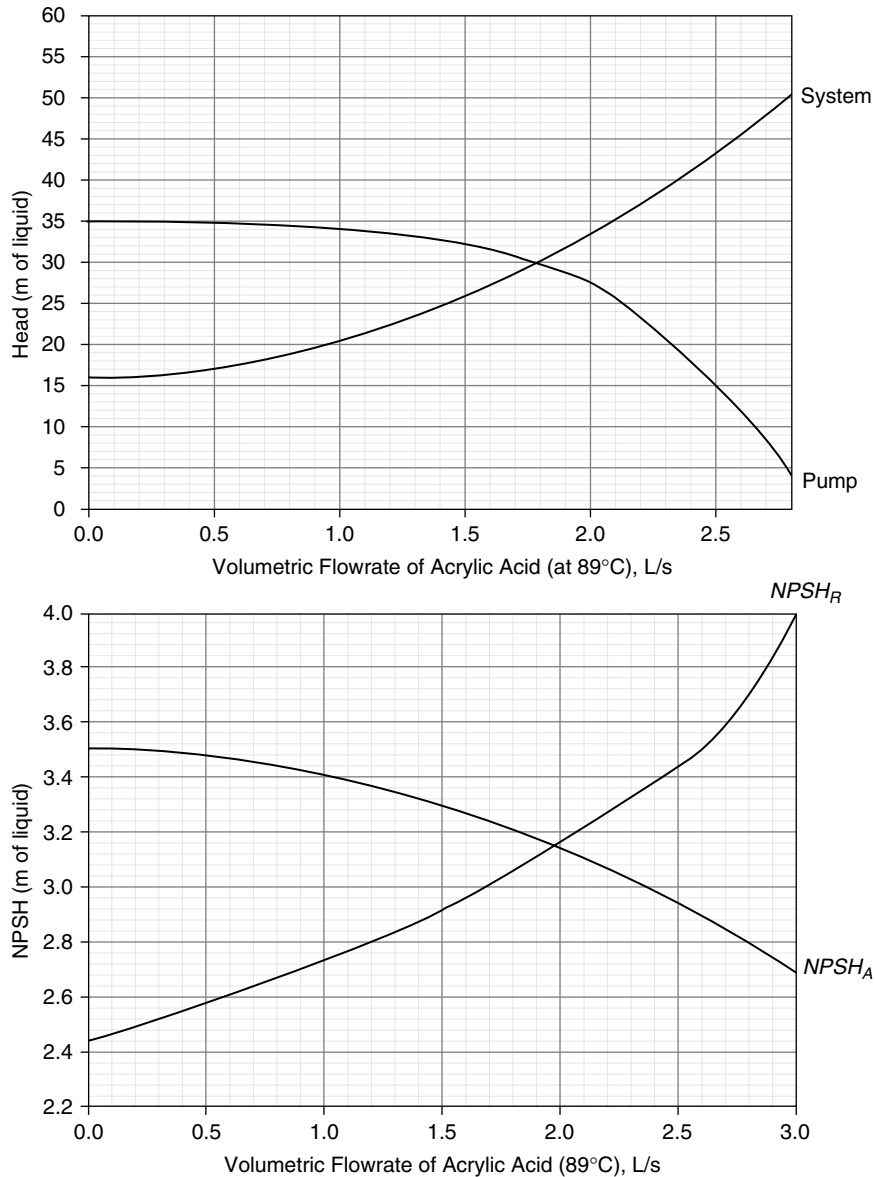

Figure P19.69 Volumetric Flowrate of Acrylic Acid (at 89°C), L/s

- b. At what flowrate does the pump produce 33.5 m of head? What is the system frictional loss at this flowrate? What is the pressure drop across the control valve at this flowrate?
 - c. At what flowrate does cavitation become a problem?
 - d. What is the maximum possible flowrate?
 - e. If the source and destination pressures are identical, what is the elevation difference between source and destination?
 - f. At a flowrate of 1 L/s, what is the system frictional head loss?
 - g. At a flowrate of 1 L/s, what head is developed by the pump?
 - h. At a flowrate of 1 L/s, what is the head loss across the control valve?
70. Benzene at atmospheric pressure and 41°C is in a tank with a fluid level of 15 ft above a pump. The pump provides a pressure increase of 50 psi to a destination 25 ft above the tank fluid level. The suction line to the pump has a length of 20 ft and is 2-in, schedule-40. The discharge line has a length of 40 ft to the destination and is 1.5-in, schedule-40. The flowrate of benzene is 9.9 lb/sec.
- a. Derive an expression for the NPSH in head units (ft of liquid) vs. flowrate in ft³/s.
 - b. Derive an expression for the system curve in head units (ft of liquid) vs. flowrate in ft³/s.
 - c. Locate the operating point on both plots on Figure P19.70.
 - d. What is the maximum flowrate before cavitation becomes a problem?
 - e. What is the pressure drop across the valve at the operating point?
 - f. What is the maximum flowrate possible with one pump, two pumps in series, and two pumps in parallel?

Data:

$$\log_{10} P_{benzene}^* (\text{mmHg}) = 6.90565 - \frac{1211.033}{T(^{\circ}\text{C}) + 220.79}$$

$$\rho_{benzene} = 51.9 \text{ lb/ft}^3$$

$$\mu_{benzene} = 0.85 \text{ cP}$$

71. Acrylic acid at 89°C and 0.16 kPa ($\rho = 970 \text{ kg/m}^3$, $\mu = 0.46 \text{ cP}$) leaves the bottom of a distillation column at a rate of 1.5 L/s. The bottom of a distillation column may be assumed to behave like a tank containing vapor and liquid in equilibrium at the temperature and pressure of the exit stream. The liquid must be pumped to a railroad heading supply tank 4.0 m above the liquid level in the distillation column, where the pressure must be 116 kPa. The liquid level at the bottom of the distillation column is 3.5 m above the pump suction line, and the frictional head loss for the suction line including the tank exit is 0.2 m of acrylic acid. There is a cooler after the pump with a pressure drop of 3.5 m of acrylic acid. The discharge line is 1.5-in, schedule-40, commercial-steel pipe, with an equivalent length of 200 m. The entire process may be assumed to be isothermal at 89°C. The problem at hand is whether this system can be scaled up by 20%. The plots required for this analysis are in Figure P19.71.
- a. Based on a pump/system curve analysis, can this portion of the process be scaled up by 20%? If not, what is the maximum scale-up percentage?
 - b. Based on an NPSH analysis, is it good operating policy for this portion of the process to be scaled up by 20%? If not, what is the maximum recommended scale-up percentage?

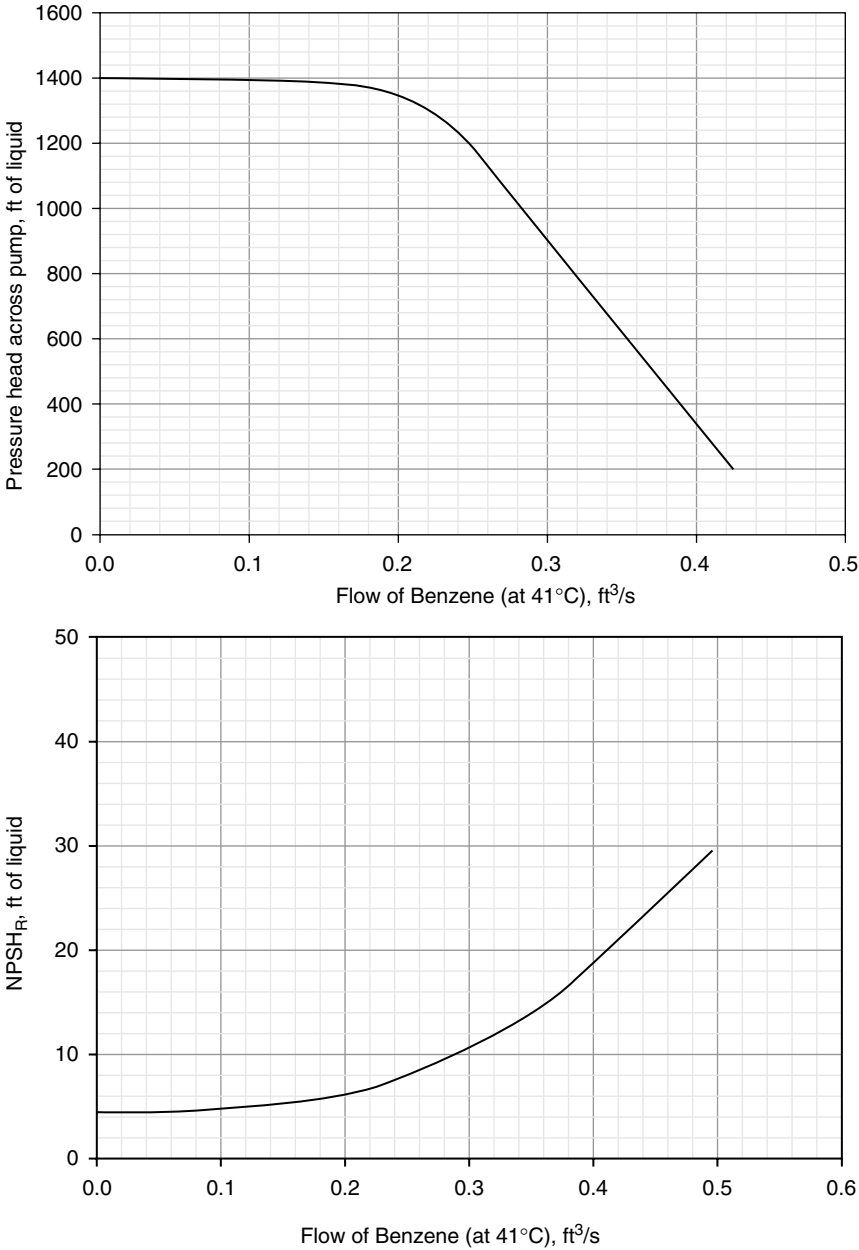

Figure P19.70 Flow of Benzene (at 41°C), ft³/s

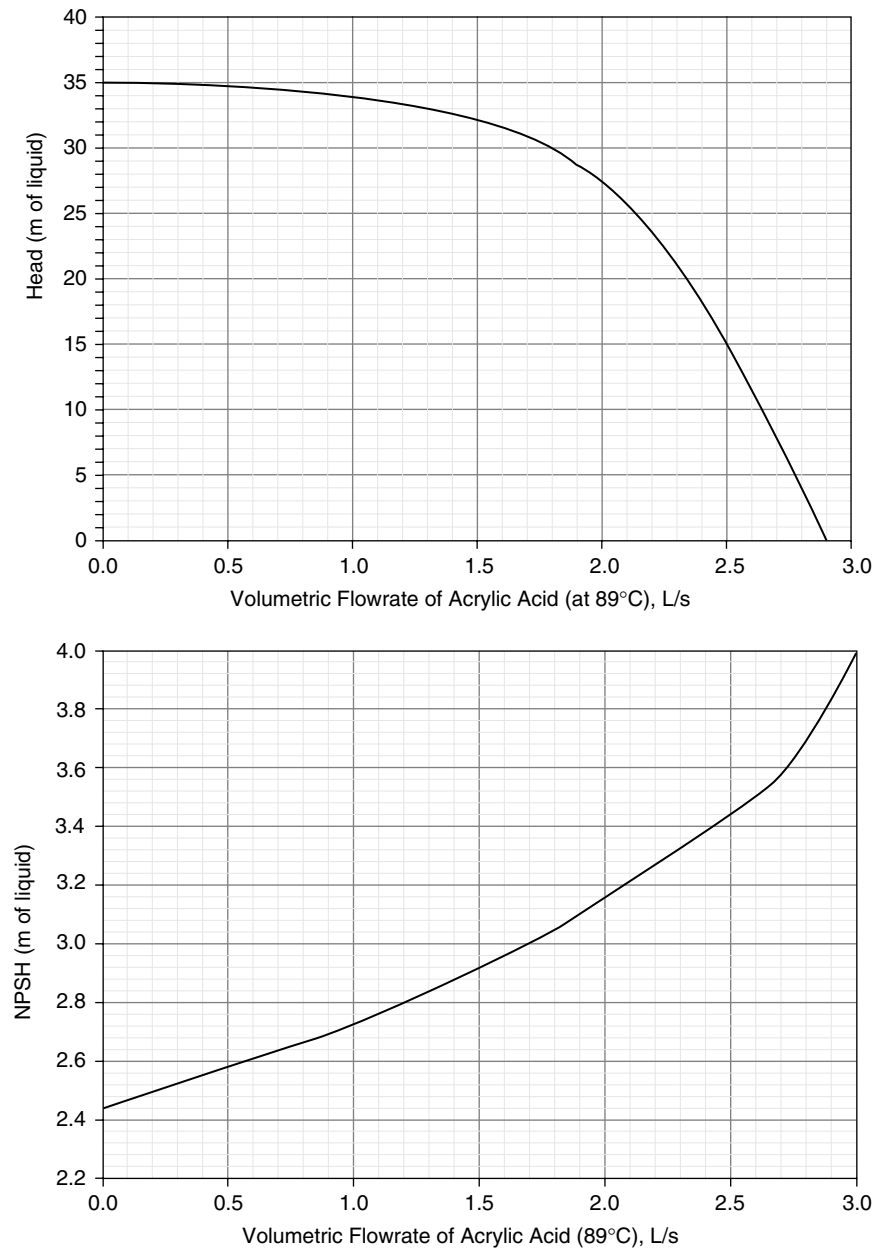

Figure P19.71 Volumetric Flowrate of Acrylic Acid (89°C), L/s

72. Consider the pump and system curves indicated by the data in Table P19.72. Answer the following questions.
- If the source and destination are at the same height, what is the pressure change from source to destination?
 - The operating condition is 1.2 L/s. What is $\Delta P_{friction}$ at this point?
 - At 1.2 L/s, what pressure change does the pump provide?
 - At 1.2 L/s, what is the pressure drop across the control valve following the pump?
 - What is the maximum flowrate possible with this (assumed single) pump?
 - What is the maximum flowrate possible with two identical pumps in series?
 - What is the maximum flowrate possible with two identical pumps in parallel?

Table P19.72

Pump Curve		System Curve	
Pressure Developed (kPa)	Flowrate (L/s)	Pressure Change (kPa)	Flowrate (L/s)
225.0	0.00	54.0	0.00
225.0	0.40	59.0	0.50
225.0	0.80	80.0	1.00
224.0	1.20	115.0	1.50
220.0	1.50	200.0	2.00
185.0	1.86	559.0	2.50
0.0	2.60		

This page intentionally left blank

Index

Numbers

- 3-D figures, improper use in oral presentations, 1217
- 3-D representation of process (plant model)
 - 3-D immersive training simulators (ITS), 45
 - create preliminary plot plan, 34–37
 - divide PFD into logical subsystems, 34–35
 - elevation for all major equipment, 39–41
 - estimate major process pipe sizes, 37–38
 - overview of, 34
 - placement of equipment, 39–40
 - sketch major process and utility piping, 41
 - view plant model, 41–43

A

- ABET engineering program accreditation
 - engineer-in-training (EIT) certification, 1122–1124
 - outcomes assessment and, 2
- Absorbers
 - in acid-gas removal (AGR) plant, 457
 - heuristics for packed towers, 364
 - input for process simulation, 411
 - recycling inerts and, 76
 - separation of allyl chloride with HCl, 402–403
 - stripping columns as reboiled, 378
- Absorption approach, to recycling raw materials, 72
- Abstracts
 - executive summaries vs., 1198–1199
 - written report guidelines, 1203–1204
- Accelerated depreciation schemes, 273
- Accelerated successive substitution (or relaxation) methods, in steady-state simulation, 578
- Accident statistics, in risk assessment, 1132–1133
- Accuracy, in capital cost estimates, 172–174
- Acetone production from isopropyl alcohol
 - making it greener, 1171
 - overview of, 1338
 - preliminary equipment summary, 1341–1343
 - process description, 1338–1339
 - reaction kinetics, 1338, 1344
 - references, 1346
 - simulation (CHEMCAD) hints, 1344
 - stream table, 1340
 - utility summary table, 1343
- ACGIH (American Conference of Governmental and Industrial Hygienists), air contaminants standard, 1135
- ACGIH (American Conference of Governmental and Industrial Hygienists), air contaminants standards, 1135
- Acid-gas removal (AGR)
 - directed graph of, 573
 - equation-oriented approach, 585–586
 - flowsheet using chilled methanol, 581–582
 - simple flowsheet of, 572–573
 - steady-state simulation examples, 580–585
- ACM (Aspen Custom Modeler), user-added models (UAMs), 563
- Acrylic acid
 - separation example. *See* Steam ejectors
 - troubleshooting off-specification product, 1076–1078
- Acrylic acid production from propylene
 - overview of, 1329–1330
 - preliminary equipment summary, 1333–1336
 - process description, 1330–1331
 - reaction kinetics and reactor configuration, 1331–1333, 1337
 - references, 1337
 - simulation (CHEMCAD) hints, 1337
 - stream table, 1332–1333
- ACS (American Chemical Society), codes of conduct, 1119
- Activated sludge, in biological waste treatment, 390
- Activation energy, in reaction kinetics, 1300, 1306, 1375
- Active pharmaceutical ingredient (API), production of, 92–97
- Activity-coefficient models
 - binary interaction parameters (BIPs) and, 417
 - for electrolyte systems, 429–430
 - for hybrid systems, 423
 - liquid-state, 418–419
 - for LLE, 419, 421–422
 - for SLE, 441
 - using thermodynamic models, 424
 - for VLE, 371, 419–420
- Actual rate of interest, compound interest calculations, 254
- Adams-Bashford method, 636
- Adams-Moulton method, 636
- Adiabatic flow, friction factors, 719–720
- Adiabatic mixer, tracing chemical pathways, 135–136
- Adiabatic splitters
 - identifying recycle and bypass streams, 144–145
 - tracing chemical pathways, 135–136
- Advanced process control (APC), 682–683
- AES (Aspen Engineering Suite), dynamic simulation, 626, 628, 630, 641–642
- Agitated columns, in extraction equipment, 943–944, 946
- AGR. *See* Acid-gas removal (AGR)
- Air
 - leaks into vacuum systems, 1050–1051
 - removing heat from process stream, 676–678
- Air contaminant standards
 - Clean Air Act (CAA), 1161
 - Environmental Protection Agency (EPA), 1140–1142
 - OSHA and NIOSH, 1135–1136
- Air-cooled heat exchangers, LMTD correction factor for, 797
- Alcohol fuel, coal to, 12
- Allyl chloride (3-chloro-1-propene) production,
 - design for increasing additional background information, 1386–1388
 - background, 1381
 - equipment design parameters, 1384
 - process description of allyl chloride facility, 1382–1385
 - process design calculations, 1388–1393
 - process flow diagram, 1382
 - reference, 1393
 - utility summary table, 1383
- Allyl chloride production, design new
 - 20,000-metric-tons-per-year facility assignment, 1394–1395
- Allyl chloride reactor, debottlenecking, 1085–1091
- Aluminum
 - material selection for, 194–197
 - thermal conductivity, 800–801
- American Chemical Society (ACS), codes of conduct, 1119–1120
- American Chemistry Council, Responsible Care program, 1143
- American Conference of Governmental and Industrial Hygienists (ACGIH), air contaminants standard, 1135
- American Institute of Chemical Engineers (AIChE)
 - Center for Chemical Process Safety (CCPS), 1143
 - code of ethics, 1110–1111, 1127
 - Design Institute for Emergency Relief Systems (DIERS), 1143
 - Design Institute for Physical Property Research (DIPPR), 402
 - Dow Fire & Explosion Index, 1150
 - Loss Control Credit Factors, 1151
 - rules and regulations, 1134

- American Institute of Chemical Engineers (AIChE), Code of Ethics
 overview of, 1110–1112
 whistle-blowing, 1115–1117
- American National Standards Institute (ANSI), 1143
- American Petroleum Institute (API)
 definition of storage tanks, 1016
 Recommended Practices, 1143
- American Society for Testing and Materials (ASTM), 1143
- American Society of Mechanical Engineers (ASME)
 boiler and pressure vessel code, 1016, 1143
 symbols for flowsheets, 16
- Amortization method, evaluating profitability of equipment, 302–303
- Analysis of means, parametric optimization, 487
- Annuity
 calculating with cash flow diagrams, 260–261
 calculating with discount factors, 261–265
- Annular fins of constant thickness, 833–837
- Annular fins of nonuniform thickness, 829–832
- ANSI (American National Standards Institute), 1143
- Antifouling chemicals, 223
- APC (advanced process control), 682–683
- API (active pharmaceutical ingredient), production of, 92–97
- API (American Petroleum Institute)
 definition of storage tanks, 1016
 Recommended Practices, 1143
- Application level, Bloom's Taxonomy, 3
- Aqueous electrolyte system, building simulator model, 435–440
- ASME (American Society of Mechanical Engineers)
 boiler and pressure vessel code, 1016, 1143
 symbols for flowsheets, 16
- Aspartame. *See* L-phenylalanine and L-aspartic acid, batch production
- Aspen Custom Modeler (ACM), user-added models (UAMs), 563
- Aspen Engineering Suite (AES), dynamic simulation examples, 626, 628, 630, 641–642
- Assessment, of group effectiveness, 1178–1180
- Assigned functions, writing reports using, 1202
- Assigned sections, writing reports, 1201–1202
- Assignment memorandum, writing reports, 1221–1222
- ASTM (American Society for Testing and Materials), 1143
- Attenuation, inherently safe design, 1153
- Audience analysis
 in oral communication, 1209, 1214
 in written communication, 1196
 for written design reports, 1208–1209
- Augmented reality (AR), 46–47
- Authenticate, in PAR process, 349–351
- Auto-ignition temperature, defined, 1143–1144
- Auxiliary facility costs, 183, 201–203
- Axes, labeling graphs for design reports, 1200
- Axial compressors, 708
- Azeotropic distillation
 in binary systems, 379–382
 overview of, 378–379
 in ternary systems, 382–388
- B**
- Back-of-the-envelope calculations, heuristics, 348
- BACT (best available control technology), pollution prevention, 1166
- Baffles, S-T heat exchanger design, 784–788, 810
- Bar charts
 histograms in design reports, 1200
 report guidelines, 1206
- Bare module equipment costs
 algorithm for calculating, 200–201
 at base conditions, 186–189
 CAPCOST calculations for, 204–206, 1269–1275
 estimating materials of construction (MOCs), 194–199
 module costing technique, 185
 at non-base conditions, 189–194
- Base case
 in PFD synthesis, 372–375, 388–389
 in process simulation, 411, 414–415
 as starting point for optimization, 469–470
- Base-case ratios
 analyzing condenser performance after scale-down, 938–939
 performance of feed section, 753–754
 performance of fluid flow equipment, 736–739
 troubleshooting steam release in cumene reactor, 1080
 troubleshooting via debottlenecking, 1089
- Base costs, analyzing in optimization, 471
- Batch optimization
 addition of market constraints, 491–492
 considering other equipment, 492–495
 optimum cycle time and, 495–497
 overview of, 490
 problem formulation, 491
 scheduling equipment and, 490–491
- Batch processes
 in chemical product design, 131
 deciding to use continuous processes vs., 56–60, 79
 defined, 56
 design calculations for, 91–97
 designing distillation columns and, 409
 equipment design for multiproduct, 111–113
 flowshop plants, 101–103
 Gantt charts and scheduling, 97–98
 intermediate storage, 108–110
 jobshop plants, 103–106
 logic control used in, 680–682
 nonoverlapping/overlapping operations and cycle times, 98–101
 overview of, 91
 parallel process units, 110–111
 product storage for single-product campaigns, 106–108
- Batch reactors, 408, 975
- Batch sequencing, 91
- BCF (bioconcentration factor), estimating fate of chemicals in environment, 1163
- Benchmarks
 for acceptable rate of return on investments, 298–299
 in optimization, 470
- Benzene. *See also* Toluene HDA process
 block flow process diagram for production of, 11–12
 in cumene production. *See* Cumene production facility problems
 determining profit margin with input/output diagram, 68–69
 distillation column performance, case study, 934–942
 evaluation of high-pressure phase separator, 164
 input/output structure, 61–63
 limitations of tracing chemical pathways in PFDs, 145–146
 in maleic anhydride production. *See* Maleic anhydride production from benzene
 PFD for production of, 21–26
 piping and instrumentation diagram for production of, 27–29
 primary chemical pathways, 137–138
 producing via hydrodealkylation of toluene, 7
- Best available control technology (BACT), pollution prevention, 1166
- Best case scenarios, quantifying risk, 314–315
- BFDs. *See* Block flow diagrams (BFDs)
- Bfw. *See* Boiler feed water (bfw) system
- Binary azeotropic distillation, 379–382
- Binary interaction parameters (BIPs)
 back-calculating for VLE data, 1283, 1361
 equations of state and, 417–418
 estimating thermodynamic model for VLE calculation, 601–604
 gathering physical property data for PFD design, 371
- Bioconcentration factor (BCF), estimating fate of chemicals in environment, 1163
- BIPs. *See* Binary interaction parameters (BIPs)
- Birmingham Wire Gauge (BWG) tubing, 800–801
- Blame, friction in groups from, 1181
- Blast wave, in explosions, 1144
- Blenders
 bare module factors for, 1274
 equipment cost data for, 1249
 purchase costs for, 1259
- BLEVE (boiling-liquid expanding-vapor explosion), 1144
- Block-decomposition algorithm, equation-oriented (EO) approach, 585–586
- Block flow diagrams (BFDs)
 in design reports, 1200
 developing new chemical process using, 10
 features of, 63–65
 identifying primary chemicals in, 136
 overview of, 11
 plant diagram, 12–13
 process diagram, 11–12
 synthesizing PFD from. *See* Synthesis of PFD, from BFD

- Blocks
 in generic block flow process diagram, 63
 unsupported in dynamic simulation, 622
- Bloom's Taxonomy of educational objectives,
 student self-assessment, 3–4
- Blowdown losses
 utility costs for cooling water tower, 221,
 223–224
 utility costs for steam production, 229
- Blowers
 heuristics for, 361
 increasing pressure of gases, 707
 material factors for, 1272
- Boil-up rate
 debottlenecking strategies for reboiler, 939
 handling reduction in feed, 935
 increasing, 855–857
 manipulating when high purity is needed,
 411
- Boiler feed water (bfw) system
 exchanging heat between process streams
 and utilities, 676–678
 regulation scheme for Cumene reactor, 684
 utility costs for steam production, 229–234
- Boilers
 debottlenecking strategies for, 939
 distillation columns requiring reboiler,
 477
 regulating utility streams in chemical plants,
 676
 thermosiphon reboilers, 40–41, 633, 779
 waste heat, 234, 823–824
- Boiling heat transfer coefficients
 determining critical or maximum heat flux in
 pool boiling, 815–816
 effects of forced convection on, 817–822
 film boiling, 822–824
 for nucleate (pool) boiling, 816–817
 typical pool boiling curve, 813–815
- Boiling-liquid expanding-vapor explosion
 (BLEVE), 1144
- Boiling point
 distillation exploiting, 876
 estimating fate of chemicals in environment,
 1163
- Book value, depreciation and, 270
- Bottlenecks
 analysis of fluid flow equipment, 736
 debottlenecking to eliminate, 939, 1066
 troubleshooting via debottlenecking, 1085–
 1091
- Bottom-up approach, in optimization, 468
- Boundary, ternary azeotropic distillation, 386–
 387
- Boundary value design method (BVDM), for
 azeotropic distillation in ternary
 systems, 382–383
- Boundary value design method (BVDM), for
 azeotropic distillation in ternary
 systems., 386
- Brainstorming
 ideas in chemical product design, 127–128
 optimization and, 465–467
 as problem-solving strategy, 1067–1068
 using in HAZOP method, 1146–1147
- Briefings, oral presentation via, 1211
- Broyden's method
 performance for tear stream convergence,
 583
 for steady-state simulation, 579–585, 587–
 588
- Bubble cap trays, for separation, 913
- Bubble phase, bubbling fluidized bed reactors,
 999
- Bubbling fluidized beds
 fluidized bed reactors, 999–1000
 two-phase model, 1002
- Business codes of conduct, 1126–1127
- Butenes. *See* Heptenes production
- BVDM (boundary value design method), for
 azeotropic distillation in ternary
 systems, 382–383, 386
- BWG (Birmingham Wire Gauge) tubing, 800–
 801
- By-products
 choosing separation units for PFD synthesis,
 376
 eliminating unwanted nonhazardous/
 hazardous, 477–478
 reactor design for PFD synthesis, 373
- By-products (unwanted)
 in batch vs. continuous processes, 56
 DIPB example, 474–475
 eliminating, 587–588
 eliminating nonhazardous, 473–475
 reactions producing, 978
 recycling, 77
 reducing in green engineering, 1164
 separator designs and, 64
- Bypass streams, in chemical processes, 142–145
- C**
- C programming language, user-added models,
 563
- CAA. *See* Clean Air Act (CAA)
- CAD (Computer aided design) programs, for
 3-D representation, 33
- Calculator blocks, in process simulation, 572
- Calibration, of thermodynamic model, 422–423
- Capacity. *See also* Heat capacity
 of common process units, 356
 impacting purchased equipment cost, 175–
 179
 plant costs based on, 206–208
- CAPCOST program
 bare module and material factors for heat
 exchangers, process vessels and pumps,
 1267–1271
 bare module and material factors for
 remaining equipment, 1271–1275
 calculating plant costs, 204–206
 cost curves for purchased equipment, 1247–
 1263
 material factors in equipment cost, 1272–
 1274
 Monte-Carlo (M-C) simulation used with,
 325
 pressure factors in costs, 1264–1266
 in single-variable optimization, 480–481
- CAPE-OPEN-compliant UAMS, 563
- Capital cost estimation
 bare module equipment costs at base
 conditions, 186–189
 bare module equipment costs for non-base-
 case conditions, 189–194
 bare module factor and bare module cost,
 199–201
 base-case analysis using, 469–470
 based on capacity information, 175–179,
 206–208
 classifications of cost estimates, 172–175
 defined, 171
 equipment costs, 175–181
 equipment installation, 182–183
 expressed in dollars, 213
 grassroots and total module costs, 201–202
 incremental analysis of, 308–309
 Lang Factor method, 184–185
 materials of construction (MOCs), 194–199
 module costing technique, 185
 overview of, 169, 171
 plant costs, 182–206
 retrofitting evaluated with, 305–309
 time impacting purchased equipment cost,
 179–181
 for total plant, 182–184
 using CAPCOST, 204–206
- Capital equipment-costing program. *See*
 CAPCOST program
- Capital investment, and pollution prevention,
 1167–1168
- Capitalized cost factor, 300–302
- Capitalized cost method, 300–302
- Capstone design class
 outcomes assessment by faculty, 4–6
 student self-assessment of outcomes, 2–4
- Carbon dioxide (CO₂)
 converting CO to, 1352–1356
 removal. *See* CO₂ and H₂S removal from coal-
 derived syngas
- Carbon monoxide (CO), converting to CO₂,
 1352–1356
- Carbon steel, selecting materials of
 construction, 194–197, 356
- Carnot efficiency, for mechanical refrigeration
 systems, 225–226
- Cascade diagrams
 heat-exchanger network (HEN) design, 523–
 524
 mass-exchange network (MEN) design, 543–
 544, 546–547
 using HENSAD program to design, 540
 using MUMNE algorithm for HENS, 514–516
- Cascade regulation, 668–669, 684
- Case studies
 distillation column performance, 934–942
 regulation and control of chemical processes,
 683–688
 report-writing. *See* Report-writing
 case study
 toluene HDA process, 426–428
 troubleshooting multiple units, 1076
- Cash criterion, evaluating profitability,
 287–288
- Cash criterion, profitability and, 291–293

- Cash flow diagrams (CFDs)
 annuity calculation using, 260–261
 calculations using, 259–260
 capital depreciation using, 268–273
 commonly used factors in, 262
 cumulative. *See* Cumulative CFD (cash flow diagram)
 cumulative cash flow diagram and, 258–259
 discount factors and, 261–265
 discrete. *See* Discrete CFD (cash flow diagram)
 in engineering economic analysis, 255–256
 profitability analysis of new project, 285–287
 taxation, profit and, 274–277
- Catalysts
 adding to feed, 66
 development of new, 60, 124
 feed purity and, 66
 filtration in batch processes, 94–96
 matching volume with heat transfer in reactors, 997–999
 pollution prevention and, 1165
 reaction kinetics data for PFD design, 370–371
 reactor design and, 372
 recycle feed and, 73–76
- Catalytic chemical reactions, 154, 962
- Catalytic reactors
 case study, 683–685
 maleic anhydride production from benzene, 1305–1311
 using dynamic simulation, 618–619
- Categorizing grid (memory matrix), in outcomes assessment, 4
- Cause analysis, in troubleshooting strategy, 1066
- Cavitation, pump, 739–740
- CCP (Cumulative cash position), profitability criteria, 287–291
- CCPS (Center for Chemical Process Safety), AIChE, 1143
- CCR (Cumulative cash ratio), profitability criteria, 287–291
- Ceiling concentration, air contaminant limits, 1135
- Center for Chemical Process Safety (CCPS), AIChE, 1143
- Center for Engineering, Ethics and Society, 1118
- Centrifugal compressors
 overview of, 708
 performance curves for, 749–750
 positive displacement compressors vs., 709
- Centrifugal extractors, 943, 945–946
- Centrifugal pumps
 increasing pressure/regulating flowrate, 674–675
 performance analysis of fluid flow in, 745–749
- Centrifuges
 bare module factors for, 1274
 equipment cost data for, 1249
 purchase costs for, 1259
- CEPCI. *See* Chemical Engineering Plant Cost Index (CEPCI) index
- Ceramics, advantages/disadvantages of, 356
- CFDs. *See* Cash flow diagrams (CFDs)
- Change, human trait of resistance to, 369
- Charter statement, in forming stage, 1184
- Check valves, 706
- Checklists
 P&IDs in construction phase as, 31
 in Process Hazard Analysis, 1146
- CHEMCAD process, single-variable optimization, 480
- Chemical components, for PFD synthesis, 401
- Chemical Engineering Plant Cost Index (CEPCI) index
 CAPCOST program, 204–206
 changes from inflation, 183–184
 changing fuel costs from 2001–2016, 220
 values from 1996 to 2011, 179–181
- Chemical equilibrium, modeling electrolyte systems, 432
- Chemical Market Reporter* (CMR), raw material costs, 234, 236–237
- Chemical process diagrams. *See also* Graphical representations
 3-D plant model, 41–43
 3-D representation of a process, 34–41
 additional diagram types, 32–33
 BFDs. *See* Block flow diagrams (BFDs)
 immersive training simulators (ITS), 45
 linking ITS with OTS systems, 46–48
 operator training simulators (OTS), 43–45
 overview of, 8–10
 P&IDs. *See* Piping and instrumentation diagrams (P&IDs)
 process concept diagrams, 60–61
 process flow diagrams. *See* Process flow diagrams (PFDs)
- Chemical process industry (CPI), scope and products, 9
- Chemical process industry (CPI), scope and products of, 9
- Chemical product design
 batch processing, 131
 economics of, 131–132
 as future of chemical engineering, 124
 generation of ideas for, 127–128
 manufacturing process, 130–131
 overview of, 123–124
 product need and, 125–127
 selection process, 128–130
 strategies for, 124–125
- Chemical reactions
 case study of acetone production, 1339–1341
 catalytic, 154, 962
 chemicals required but not consumed, 62
 CSTRs used for liquid-phase, 980–984
 distillation of reaction products in batch processes, 92–94
 endothermic. *See* Endothermic reactions
 excess reactants affecting recycle structure, 76
 exothermic. *See* Exothermic reactions
 heat integration and. *See* Heat integration
 heat transfer and, 76
 inert materials in controlling, 77, 154
 ionic reactions, 432, 435–440, 447
 pressure impact on, 150
 process concept diagram in identifying, 60–61
 rate of. *See* Reaction rates
 reaction kinetics. *See* Reaction kinetics
 reaction vessels, 92–94
 reactor design and, 372–373
 reasons for operating at conditions of special concern, 152–154
 resource materials for, 84
 runaway reactions, 1145
 temperature impact on, 150–151
- Chemical reactors. *See* Reactors
- Chemical Safety and Hazard Investigation Board, 1153
- Chemicals, fate of in environment, 1160–1163
- Chemistry, green, 1163–1164
- Choked flow, friction factors in, 720–722
- CIDs (composition interval diagrams), mass-exchange networks (MENs), 541–543, 546
- Circular fins of nonuniform thickness, fin efficiency, 830
- Circular flags, in P&IDs, 29–30
- Circulating fluid-bed reactors, 1001
- Citations of other work
 for equations in reports, 1207–1208
 for figures and tables in reports, 1206
 in report references, 1200
- Classification, of capital cost estimates, 172–175
- Claus process, defined, 1363
- Claus unit design, converting H₂S to elemental sulfur
 major equipment summary, 1367–1368
 process description, 1363, 1368–1369
 process flow diagram, 1364
 reaction kinetics, 1369–1370
 references, 1370
 simulation (Aspen Plus) hints, 1370
 stream table, 1365–1366
 utility summary table, 1367
- Claus unit design, defined, 1363
- Clean Air Act (CAA)
 on fugitive emissions, 1166
 regulations, 1140–1141
 Risk Management Plan of EPA, 1141–1142
 summary of, 1161
- Clean Water Act (CWA)
 EPA regulations, 1161
 planned emissions, 1140
- Closed-cup measurement, flash point of liquid, 1144
- CMR (*Chemical Market Reporter*), raw material costs, 234, 236–237
- CO₂ and H₂S removal from coal-derived syngas
 major equipment summary, 1361–1362
 overview of, 1356
 process description, 1356–1358
 process flow diagram, 1359
 references, 1362
 simulation (Aspen Plus) hints, 1358, 1362
 stream table, 1358–1360
 utility summary table, 1360, 1362
- Coal
 CO₂ and H₂S removal. *See* CO₂ and H₂S removal from coal-derived syngas
 PFD for coal to alcohol fuel, 12–13
 utility costs and, 219

- Coalescence equipment
 - L-L separation via, 1046–1047
 - layouts for L-L separators, 1047–1049
- Coast Guard, regulating transport of hazardous cargo, 1141
- Cocurrent flow
 - limiting temperature profiles for, 775
 - LMTD correction factor for, 791, 797
 - overview of, 773–775
- Cocurrent separations, mass separating agents and, 903
- Code of Federal Regulations (CFR)
 - health, safety and environment, 1134
 - legal liability of chemical engineers, 1126
- Codes of ethics
 - American Institute of Chemical Engineers (AIChE), 1110–1112, 1119–1120
 - National Society of Professional Engineers (NSPE), 1113–1114
 - overview of, 1110
 - whistle-blowing requirements in, 1115
- Cognitive domain, Bloom's Taxonomy as, 3–4
- Cohen-Coon tuning rule, dynamic simulation, 641
- Cohen-Coon tuning rules, process control in dynamic simulation, 641–643
- Colburn equation, for continuous differential separations, 906–910
- Colburn graph, troubleshooting packed-bed absorbers, 1072
- Colors, oral presentations using, 1213, 1217
- Columns
 - condensers, reboilers and designing, 923–926
 - flooding and diameter of, 914–920
 - labeling in tables for design reports, 1200
- COM (cost of manufacturing). *See* Manufacturing cost estimates
- Combination feedback/feed-forward system, 667
- Combustion
 - defined, 1143
 - fires, explosions and, 1143–1145
 - reducing in green engineering, 1165
- Committee, writing by, 1202
- Commodity chemicals, 123
- Common Denominator Method, profitability of equipment with different operating lives, 303–304
- Communication
 - audience analysis and, 1196
 - of optimization results, 468
 - oral. *See* Oral communication
 - written. *See* Written communication
- Competency, choosing group members for, 1182
- Component database, simulator features, 398
- Composite temperature-enthalpy diagrams
 - designing with HENSAD program, 540
 - estimating heat-exchanger surface area, 525–529
 - showing minimum temperature approach, 523–524
 - for systems without a pinch, 524–525
- Composition interval diagrams (CIDs), mass-exchange networks (MENS), 541–543, 546
- Composition, measurement of process variables, 662
- Compound adjectives, written report guidelines, 1203
- Compound interest
 - calculating, 252–253
 - continuously compounded, 255
 - defined, 252
 - interest rates changing over time and, 253
 - time basis in calculating, 254–255
- Comprehension level, Bloom's Taxonomy, 3
- Comprehensive Environmental Response, Compensation, and Liability Act (CERCLA)
 - EPA regulations impacting, 1141
 - retroactive liability in, 1168
 - summary of environmental laws, 1161
- Compressible frictional flow
 - for choked flow, 721–723
 - for fluid in pipes, 719–720
- Compression
 - in single-stage steam ejectors, 1052
 - steam ejector performance and, 1057–1058
 - utility costs for refrigeration, 225–228
- Compressors
 - bare module cost for, 1270
 - bare module factors for, 1271
 - capacities of process units in common usage, 356
 - conditions of special concern for, 155–158
 - equipment cost data for, 1249
 - feed section performance and, 751–755
 - as fluid flow equipment, 707–708
 - fluid flow performance analysis of, 749–752
 - heuristics for, 361
 - increasing pressure of gases, 707
 - increasing pressure/regulating flowrate with, 674–676
 - input for process simulation, 406
 - material factors for, 1272
 - mechanical energy balance in piping systems and, 700–703
 - physical property data for PFD synthesis, 371
 - pressure factors for, 1265
 - purchase costs for, 1252
 - staging of, 750–752
 - utility cost estimates for, 238–240
- Computational blocks, steady-state simulations, 571–572
- Computational cost, sequential modular approach, 574
- Computer aided design (CAD) programs, for 3-D representation, 33
- Concentration control, with multiple reactors, 76
- Concentration profiles, in nonisothermal plug flow reactors, 987–989
- Concept scoring, in chemical product design, 129–130
- Concept screening, in chemical product design, 129
- Condensate-return header pressure, utility costs for steam, 229
- Condensation
 - drums used in partial, 911–912
 - heat transfer and, 824–828
 - TP-xy diagrams showing partial, 883
- Condensers
 - impact on performance of distillation columns, 934–942
 - in tray towers, 923–926
 - using partial, 896
 - utility costs for refrigeration, 225–228
- Conditions of special concern (separation and reactor systems)
 - analyzing and justifying in PCM, 158–164
 - for operation of other equipment, 155–158
 - pressure, 150–151
 - reasons for operating at, 152–154
 - temperature, 150–152
- Confined spaces, Process Safety Management for, 1140
- Confined spaces, regulation for workers in, 1140
- Conflict of interest, business codes of conduct, 1127
- Conjunctive adverbs, written report guidelines, 1203
- Connectors, pipe, 705
- Constant molar (or molal) overflow, in binary distillation, 890, 893
- Constant volume (positive displacement) pumps
 - increasing pressure/regulating flowrate in streams, 674–676
 - overview of, 706–707
 - performance analysis of fluid flow in, 745–746
- Constraints
 - defined, 464
 - equality vs. inequality, 464
 - in mechanical design. *See* Pinch technology optimization and, 464, 466
 - VLE and, 602
- Consumer price index, CEPCI index compared with, 183
- Containment, process safety and, 994, 1153–1154
- Contaminants, gas permeation for removal of dilute, 950
- Contingency costs
 - estimating bare module costs, 201
 - estimating total capital cost of plant, 183
- Continuous differential separations
 - calculating transfer units, 881
 - Colburn equation for dilution, 908–910
 - for dilute solutions, 905
 - model for, 878–879
 - operating line/equilibrium curves in, 905
 - separations in packed columns as, 901
- Continuous phase, in L-L separation, 1044–1047
- Continuous processes
 - deciding to use batch processes vs., 56–60, 79
 - defined, 56
 - hybrid/batch, 79, 82–83
 - logic controllers in, 680
- Continuous stirred tank reactors (CSTRs)
 - dynamic models for, 632
 - examples, 974–975
 - input for process simulation, 408

- Continuous stirred tank reactors (CSTRs)
(*continued*)
 nonisothermal, 980–984
 overview of, 972–973
 performance problems, 1003–1006
- Contractor's estimates, 172–174
- Contracts
 business codes of conduct and, 1126–1127
 legal issues for chemical engineers, 1126
- Control
 in dynamic simulation, 639–646
 oral presentation guidelines, 1214
 of process operations. *See* Control and regulation of chemical processes
- Control and regulation of chemical processes
 advanced process control (APC), 682–683
 cascade control system, 668–669
 case studies, 683–688
 characteristics of regulating valves, 657–659
 combination feedback/feed-forward control strategy, 667–669
 exchanging heat/work between process/utility streams, 674–679
 feed-forward control and regulation strategy, 665–667
 feedback control and regulation strategy, 663–665
 logic control, 680–682
 measuring process variables, 662–663
 operator training simulator (OTS), 683–688
 overview of, 655–656
 ratio control strategy, 669–671
 regulating flowrates and pressures, 660–662
 simple regulation problem, 656–657
 split-range control strategy, 671–673
- Control loops
 in dynamic simulation, 641–643, 652
 identifying/describing in PFDs, 14–15
 P&IDs and, 29–30
 PFD synthesis and, 390
- Control systems
 advanced process control (APC), 682–683
 cascade control system, 668–669
 combination feedback/feed-forward control, 667–669
 dynamic simulation in, 619
 dynamic simulation in designing, 619, 640–656
 feed-forward control, 665–667
 feedback control, 663–665
 for hazardous materials, 1154
 logic control, 680–682
 ratio control system, 669–671
 split-range control strategy, 671–673
- Control volume, in fluid mechanics, 697–698
- Controllability, continuous vs. batch processes and, 59
- Controlled variable (CV)
 SISO controllers in dynamic simulation, 640
 in split-range control, 671–673
- Convection, effects on pool boiling of forced, 817–822
- Convective film heat transfer. *See* Film heat transfer coefficients
- Convergence criteria, in process simulation, 411–412
- Conversion profiles, adiabatic packed bed reactor, 996–997
- Conveyers
 bare module factors for, 1274
 equipment cost data for, 1249
 purchase costs for, 1260
- Cooling
 in acid-gas removal, 572–573, 587, 593–596
 complex reactor performance problems and, 1004–1006
 concentration/temperature profiles in reactors and, 987–989
 configuring CSTRs, 980–984
 dynamic simulation and, 625–627, 630
 heat exchange between process streams and utilities, 676–678
 justifying operations outside temperature range for, 151–152
 in nonisothermal PFRs, 991
 nonisothermal plug flow reactors and, 991
- Cooling water tower, estimating utility costs, 221–225
- Cooperative or collaborative learning, in teams, 1189
- Coordination, of group effort, 1177–1178
- Copper and its alloys, selecting materials of construction, 194–197
- Copper, thermal conductivity in heat exchangers, 800–801
- Correction factors, estimating fate of chemicals in environment, 1160–1161
- Corrosion
 allowance in pressure vessel design, 1022
 resistance in some materials of construction, 1016, 1019–1020
- Corrugated plate settlers, L-L separation, 1046–1047
- Cost
 capital. *See* Capital cost estimation
 chemical product design, 130–131
 conditions of special concern for reactors/separators, 150–152
 heat integration and, 512
 manufacturing. *See* Manufacturing cost estimates
 of optimization, 470–471
 using continuous vs. batch processes, 60
- Cost curves, for purchased equipment
 for blenders, 1249, 1259
 for centrifuges, 1249, 1259
 for compressors, 1249, 1252
 for conveyers, 1249, 1260
 for crystallizers, 1249, 1260
 for drives, 1249, 1252
 for dryers, 1249, 1261
 for dust collectors, 1249, 1261
 for evaporators, 1249, 1253
 for fans, 1249–1250, 1254
 for filters, 1250, 1262
 for furnaces, 1250, 1255
 for heat exchangers, 1250, 1256
 for heaters, 1250, 1255
 for mixers, 1250–1251, 1262
 for packing, 1251, 1257
 for process vessels, 1251, 1258
 for pumps, 1251, 1254
 for reactors, 1251, 1263
 for screens, 1251, 1263
 for tanks, 1251, 1258
 for towers, 1251
 for trays, 1251, 1257
 for turbines, 1251, 1254
 for vaporizers, 1251, 1253
- Cost indexes
 classifying cost estimates, 173
 effect of time on purchased equipment cost, 179–181
 variations over 15 years, 177–179
- Cost of manufacturing (COM). *See* Manufacturing cost estimates
- Countercurrent flow
 continuous differential separation, 878–879
 limiting temperature profiles for, 775
 LMTD correction factor for, 791, 797
 overview of, 771–773
- CPI (chemical process industry), scope and products, 9
- Creeping flow, around submerged objects, 724–725
- Criminal prosecution, of chemical engineers, 1126
- Critical path method (CPM), group scheduling and, 1185
- Cross-flow exchangers, LMTD correction factor for, 797
- Crude oil, cost of, 220, 236–237
- Cryogenic conditions, of special concern, 152
- Crystallization
 guidelines for choosing separation units, 374
 heuristics for towers, 363
 of product in batch processing, 96–97
 solid-liquid equilibrium (SLE) and, 441
- Crystallizers
 bare module factors for, 1274
 equipment cost data for, 1249
 L-phenylalanine and L-aspartic acid production, 1328–1329
 purchase costs for, 1260
- CSTRs. *See* Continuous stirred tank reactors (CSTRs)
- CSTRs (Nonisothermal continuous stirred tank reactors)
 overview of, 980–984
 performance problems, 1004–1006
- Cumene
 basic regulation scheme, 683–685
 reactor case study, 683–685
 troubleshooting entire process, 1081–1085
 troubleshooting feed-section, 1074–1076
 troubleshooting steam release, 1078–1081
- Cumene production at new 100,000-metric-tons-per-year facility
 assignment, 1430–1431
 background, 1430
 cost of manufacture, 1432
 reaction kinetics, 1431
 report format, 1432
 simulation (CHEMCAD) hints, 1432

- Cumene production facility problems
background, 1417
equipment summary table, 1425–1426
flow summary table, 1421
process calculations, 1425–1429
process description, 1417–1418
process flow diagram, 1418–1419
pump, system, and NPSH curves, 1423–1424
reaction kinetics, 1417
recent problems, 1418–1419
specifications of products and raw materials, 1419–1420
utility summary table, 1422
- Cumulative cash position (CCP), profitability criteria, 287–291
- Cumulative cash ratio (CCR), profitability criteria, 287–291
- Cumulative CFD (cash flow diagram)
defined, 256
discounted profitability cash criteria, 292–293
discounted profitability interest rate criteria, 295
evaluating profitability of new project, 285–287
nondiscounted profitability criteria, 289–290
overview of, 258–259
- Cumulative distribution functions
Monte-Carlo analysis for quantifying risk, 321–324
probability theory, 319–321
- Cumulative Sum (CUSUM) charts, statistical process control, 682
- Curves
analyzing centrifugal compressor, 749–750
analyzing from feed section to process, 751–755
analyzing pump and system, 743–749
heat transfer coefficients for pool boiling, 813–815
increasing heat of reaction in reactors, 989
pump and compressor, in phthalic anhydride production, 1405
- CV (Controlled variable)
SISO controllers in dynamic simulation, 640
in split-range control, 671–673
- CWA (Clean Water Act)
EPA regulations, 1161
planned emissions, 1140
- Cycle times
in batch operations of optimum, 495–497
in batch processing, 100–101
flowshop plants, 101–103
- Cylindrical shells
pressure vessel design, 1016–1021
sizing pressure vessels, 1023–1024
- Cylinders, falling-film condensation on, 825–828
- D**
- DAEs (differential algebraic equations)
as dynamic simulation solution method, 633–635
method of lines generating, 631
- Data output generator, simulator features, 399
- Databases, in simulation, 562
- DCS (Distributed control system) screen, operator training simulator, 689
- DDB (double declining balance) depreciation method, 270–273
- Debottlenecking. *See also* Troubleshooting
analysis of fluid flow equipment, 736
applying to problems, 1085–1091
overview of, 1066–1067
- Decide phase, in troubleshooting strategy, 1084
- Decide step, process troubleshooting, 1068–1071
- Decision-making
friction in groups from lack of concurrence, 1181
mobile truth and ethical, 1183–1184
role of leadership in groups, 1181–1182
- Decision variables
communicating results, 468–469
estimating problem difficulty, 467–468
in flowsheet optimization, 484–487
identifying and prioritizing, 471–472
objective function and, 464
overview of, 464
in parametric optimization, 479
sensitivity studies and, 487
- Define phase, in troubleshooting strategy, 1081–1083
- Define phase, process troubleshooting, 1068–1071
- Definitive (project control) estimate, 172–173
- Deflagrations, explosions as, 1144
- DEM (dominant eigenvalue method), for steady-state simulation, 578–579
- Demand
in chemical markets, 311–314
deciding on continuous vs. batch processes, 58
- Density
flow around submerged objects and, 723
modeling distillation column for electrolyte system, 448
probability density function, 318–321
separating solids of different, 374
solids modeling and, 442
in thermodynamics, 416–417
- Department of Transportation (DOT)
legal liability of chemical engineers and, 1126
regulations for hazardous cargo, 1141
- Depreciation of capital investment
different types of, 269–273
example of calculating, 270–273
fixed capital, working capital, and land, 269
MACRS method of calculating, 273–274
overview of, 268–269
taxation, cash flow and profits in, 275–277
- Descriptive executive summaries, 1198–1199
- Design
calculations required for batch processes, 91–97
chemical product. *See* Chemical product design
heat- (mass-) exchanger networks. *See* Pinch technology
variables. *See* Decision variables
writing minutes during meetings on, 1199
- Design blocks, in process simulation, 572
- Design-by-rule philosophy, pressure vessels, 1016
- Design Institute for Emergency Relief Systems (DIERS), AIChE, 1143
- Design Institute for Physical Property Research (DIPPR), 402
- Design projects
allyl chloride production at new facility. *See* Allyl chloride production, design new
20,000-metric-tons-per-year facility
cumene production at new facility, 1430–1432
cumene production facility problems. *See* Cumene production facility problems
increasing allyl chloride production. *See* Allyl chloride (3-chloro-1-propene) production, design for increasing
introduction to, 1379–1380
phthalic anhydride production at new facility, 1412–1416
phthalic anhydride production scale down. *See* Phthalic anhydride production, scaling down
references, 1380
- Design reports
figures and tables in, 1200
written communications as, 1197–1198
- Desuperheaters, 937
- Detailed estimates, 172–174
- Detailed (firm or contractor's) estimate, 172–174
- Detonation explosions, 1144
- Deviations, HAZOP questioning process, 1147
- Diagrams, of chemical processes. *See* Chemical process diagrams
- DIERS (Design Institute for Emergency Relief Systems), AIChE, 1143
- Differential algebraic equations (DAEs)
as dynamic simulation solution method, 633–635
method of lines generating, 632
- Diffusion coefficients, in electrolyte systems
modeling, 433–434
- Diffusion, solids modeling and, 442
- Dimensionality, equality constraints
reduce, 464
- Dimethyl ether (DME) production
cascade regulation for, 668–669
chemical process for, 1278–1283
making it greener, 1171
material balance control for overhead product, 655–656
- DIPPR (Design Institute for Physical Property Research), 402
- Direct manufacturing costs, estimating for chemical product, 213–218
- Direct substitution
accelerated successive substitution (relaxation) vs., 578
performance for tear stream convergence, 583
steady-state simulation, 578
steady-state simulation examples, 580–585
- Discharge coefficient, measuring flowrate, 730–735

- Discount factors, calculating annuities, 261–265
- Discounted cash flow rate of return (DCFROR) CAPCOST program using, 325
 comparing large projects, 295–298
 interest rate criterion, 293–295
 reliable results of, 327
 sensitivity analysis for quantifying risk, 315
- Discounted criteria, evaluating profitability, 291–295
- Discounted cumulative cash position, 291
- Discounted methods, for incremental analysis, 308–309
- Discounted payback period (DPBP)
 interest rate criterion, 294
 time criterion, 291–293
- Discrete CFD (cash flow diagram)
 for annuity, 260–265
 for capital depreciation, 268
 example of, 255–256
 overview of, 256–258
- Discretionary money, 248–251
- Disengagement, friction in groups from, 1181
- Dished (or torispherical) heads, pressure vessels, 1022–1024
- Dispersed phase (droplets), in L-L separation, 1044–1047
- Disposal, in life cycle analysis, 1169
- Distillation
 approach to recycling raw materials, 72
 azeotropic, generally, 378–379
 azeotropic, in binary systems, 379–382
 azeotropic, in ternary systems, 382–388
 batch, 409
 design calculations for batch processes, 94–95, 97
 designing for optimum energy usage, 1165
 energy as separating agent in, 876
 exploiting boiling points between components, 876
 heuristics for towers used in, 363
 mass separating agents compared to, 903–904
 McCabe-Thiele method for mass separating agents, 903–905
 McCabe-Thiele method using packed columns, 901–902
 McCabe-Thiele method using tray columns, 888–901
 simple, 376–378
 TP-xy diagrams showing, 883–888
- Distillation columns. *See also* Tray towers
 basic control system for binary, 685–687
 building model of aqueous electrolyte system, 435–440
 case study on performance of, 934–942
 design cumene production at new 100,000-metric-tons-per-year facility, 1432
 drums used in, 911–912
 dynamic models and control of, 632–633
 input for process simulation, 408–409
 McCabe-Thiele method using tray columns, 888–901
 modeling for electrolyte systems, 447–450
 reasons for elevating, 39–40
 sequencing for simple distillation, 376–379
 single-variable optimization of, 480–481
 sophisticated control system for binary, 687–688
- Distributed control system (DCS) screen, operator training simulator, 689
- Distributed-parameter models, for heat exchangers, 625
- Disturbance variables (DV)
 in dynamic simulation, 619, 626
 input variables as, 617
- DMC (dynamic matrix control), model-based, 683
- DMO solver, in Aspen+, 594
- DO (drying oil) production, 1299–1304
- Dominant eigenvalue method (DEM), for steady-state simulation, 578–579
- DOT (Department of Transportation)
 legal liability of chemical engineers and, 1126
 regulations for hazardous cargo, 1141
- Double declining balance (DDB) depreciation method, 270–273, 274
- Dow Fire & Explosion Index, 1147, 1150–1152
- Downcomer channel, 911–912
- DPBP (Discounted payback period)
 interest rate criterion, 294
 time criterion, 291–293
- Drag coefficient, flow around submerged objects, 723–725
- Drainage and spill control, in Dow Fire & Explosion Index, 1152
- Drivers, heuristics for, 358
- Drives
 bare module cost for, 1270
 bare module factors for, 1271
 capacities of process units, 356
 equipment cost data for, 1249
 material factors for, 1272
 pressure factors for, 1265
 purchase costs for, 1252
- Dropletwise condensation, 824
- Drums, heuristics for. *See also* Vessels, 358
- Dryers
 bare module factors for, 1274
 equipment cost data for, 1249
 purchase costs for, 1261
- Drying oil (DO) production, 1299–1304
- Dual-stage Selexol unit design. *See* CO₂ and H₂S removal from coal-derived syngas
- Dust collectors
 bare module factors for, 1274
 equipment cost data for, 1249
 purchase costs for, 1261
- Duties and obligations, in ethical problem-solving, 1110
- DV (disturbance variables)
 in dynamic simulation, 619, 626
 input variables as, 617
- Dynamic matrix control (DMC), model-based control, 683
- Dynamic simulation integrator algorithms, solutions to DAE systems, 635–637
- Dynamic simulators
 distillation columns setup, 632–633
 dynamic specifications in, 624
 equipment geometry and size setup, 622–624
 flash separators and storage vessels setup, 630–632
 heat exchangers setup, 625
 method of lines setup, 632
 need for dynamic simulation, 618–619
 OTS required for executing, 689
 process control, 639–646
 process heat exchangers setup, 627–630
 reactors setup, 632
 series of CSTRs setup, 632
 setting up, 619
 solution methods, 634–639
 terminology for, 617–618
 topological changes from steady-state simulation, 619–622
 utility heaters/coolers setup, 625–627
- Dynamic specifications, in dynamic simulators, 624
- Dysfunctional group behavior, 1183
- E**
- E-mail, rapid written communication via, 1199
- EAOC. *See* Equivalent annual operating cost (EAOC)
- EB production. *See* Ethylbenzene (EB) production
- ECC (equivalent capitalized cost), 301
- Economics
 analysis of engineering. *See* Engineering economic analysis
 capital costs and. *See* Capital cost estimation of chemical processes, 149
 manufacturing costs. *See* Manufacturing cost estimates
 of pollution prevention, 1165, 1167–1168
 of product design, 131–132
 profitability analysis in. *See* Profitability analysis
- Economy of scale
 deciding on continuous vs. batch processes, 57
 equipment capacities and, 177–179
- Effective annual interest rate, 254–255
- Effectiveness charts, heat exchangers, 861–864
- Effectiveness factor (F), applied to S-T heat exchangers, 529–534
- Efficiency
 defining tray, 920–922
 in group synergy, 1176
 of mist eliminators in V-L separation, 1040–1044
 using continuous vs. batch processes, 58
- EIS (Environmental impact statement), 1140
- EIT (Engineer-in-Training) certification, 1122–1125
- Elbows, changing flow direction with, 705
- Electricity
 cost of, 220
 cost of manufacturing benzene, 241–242
 utility costs for plant with multiple process units, 222

- utility costs for steam production, 228–234
- utility costs from PFDs, 238–240
- Electrolyte systems modeling
 - building model of aqueous electrolyte, 435–440
 - calculating excess Gibbs free energy for, 445–447
 - calculation of Gibbs free energy for, 430
 - chemical equilibrium in, 432
 - diffusion coefficient in, 433–434
 - fundamentals of, 429–431
 - heat capacity in, 431–432
 - modeling distillation column for, 447–519
 - molar volume in, 432
 - overview of, 428
 - surface tension in, 434–435
 - thermal conductivity in, 433
 - viscosity in, 432–433
- Elevation diagrams, 32–33
- Elevation, of equipment, 39–41
- Elliptical heads, for pressure vessels, 1022–1024
- Emergencies, simulation in training for, 48
- Emergency Planning and Community Right to Know Act (EPCRA), 1141, 1161
- Emergency release of emissions, EPA, 1141
- Emissions
 - emergency release of, 1141
 - fugitive, 1166
 - green engineering for reduction of, 1159
 - pollution prevention in process design and, 1165–1166
- Employee relations, and business codes of conduct, 1127
- Endothermic reactions
 - hierarchy of reactor configurations for, 986
 - justifying reactors operating at temperature conditions of special concern, 152–153
 - reactor design and, 373
 - reactor design for PFD synthesis, 373
 - reasons for multiple reactors, 76
- Energy
 - affecting supply and demand curves, 313
 - green engineering minimizing use of, 1159
 - heat integration efficiency and. *See* Heat integration
 - loss due to friction in piping systems, 700–703
 - recovery system, 83
- Energy balance
 - in McCabe-Thiele method for distillation, 890, 892, 899
 - MERSHQ (material balance, energy balance, rate equations, hydraulic equations, and equilibrium equations) in, 436–440
 - nonisothermal CSTRs and, 980–984
 - performance problems for reactors, 1005
 - reactors and, 971–972
 - reboilers and, 924
 - relationships in separations, 877
- Engineer-in-Training (EIT) certification, 1122–1125
- Engineering economic analysis
 - annuity calculation, 260–265
 - calculations using cash flow diagrams, 259–265
 - cash flow diagrams in, 255–259
 - compound interest, 252–253
 - cumulative cash flow diagram, 258–259
 - depreciation of capital investment, 268–274
 - discrete cash flow diagram, 256–258
 - inflation, 266–267
 - interest rates changing over time, 253
 - investments, and time value of money, 248–251
 - overview of, 247–248
 - simple interest, 252
 - taxation, cash flow, and profit, 274–277
 - time basis for compound interest calculations, 254–255
 - types of interest, 251–253
- Engineering ethics, 1104, 1118–1121
- “Engineers’ Creed,” code of ethics, 1112
- Enthalpy. *See also* Temperature-enthalpy (T-Q) diagrams
 - composite enthalpy curves for systems without a pinch, 524–525
 - composite temperature-enthalpy diagram, 523–524
 - handling streams with phase changes, 539–540
 - of mechanical energy balance in piping systems, 700–703
 - MESH (material balance, phase equilibrium, summation equations, and enthalpy balance), 435–440
 - solids modeling and, 442
 - thermodynamic model, 416
- Entrainment
 - defined, 914
 - performance of steam ejectors, 1057–1058
- Envelope method, tracing primary chemical pathways, 139–140
- Envirofacts System, EPA, 1141
- Environment. *See also* Health, safety, and environment (HSE)
 - fate of chemicals in, 1160–1163
 - green engineering for. *See* Green engineering
 - life-cycle analysis (LCA) of product consequences in, 1168–1169
 - PFD synthesis and, 389
 - work, 1177
- Environmental control block, in block flow diagram, 65
- Environmental impact statement (EIS), 1140
- Environmental Protection Agency (EPA)
 - definition of “worst-case release,” 1133
 - emergency release of emissions, 1141
 - focus of, 1131
 - fugitive emissions and, 1166
 - legal liability and, 1126
 - overview of, 1140
 - planned emissions, 1140–1141
 - Risk Management Plan (RMP), 1141–1142
- Environmental regulations
 - green engineering and, 1159–1160
 - need for steady-state simulation, 562
 - Pollution Prevention Act of 1990, 1159–1160
 - summary of laws, 1161
- EO. *See* Equation-oriented (EO) approach
- EOS
 - estimation of physical property parameters, 602–604
 - solids modeling and, 443
- EPA. *See* Environmental Protection Agency (EPA)
- EPCRA (Emergency Planning and Community Right to Know Act), 1141, 1161
- Equal percentage (or constant) valves, for regulation, 658
- Equality constraints, in optimization, 464
- Equation-oriented (EO) approach
 - converging optimization problem using, 592–595
 - for linear/nonlinear equations in dynamic simulation, 637–638
 - optimization of flowsheet convergence and, 590–591
 - SMod as hybrid of SM and, 586–589
 - in steady-state simulation, 585–586
- Equations, in written design reports, 1207–1208
- Equations of state, phase equilibrium model, 417–418
- Equilibrium
 - inert materials added to feed for controlling reactions, 67–68
 - justifying conditions of special concern in reactors/separators in PCM, 158–164
 - justifying reactors/separators operating at temperature conditions of special concern, 152–154
 - liquid-liquid. *See* Liquid-liquid equilibrium (LLE)
 - MERSHQ (material balance, energy balance, rate equations, hydraulic equations, and equilibrium equations) in, 436–440
 - MESH (material balance, phase equilibrium, summation equations, and enthalpy balance) in, 435–440
 - modeling electrolyte systems with chemical, 432
 - reactor design, 372
 - reactors, 408
 - reasons for multiple reactors, 76
 - separation, 877–878
 - solid-liquid equilibrium (SLE), 441–443
 - solid-vapor equilibrium (SVE), 441–442
 - vapor-liquid. *See* Vapor-liquid equilibrium (VLE)
- Equipment
 - 3-D representation of. *See* 3-D representation of process (plant model)
 - analyzing important process conditions, 158–164
 - CAPCOST costs for purchased, 1247–1248
 - capital cost estimates for, 176
 - conditions of special concern for, 150–152, 155–158
 - constructing P&IDs, 27–29
 - for continuous vs. batch processes, 57
 - costs of installation, 182–183

- Equipment (*continued*)
- data for optimization base case, 469–470
 - debottlenecking. *See* Debottlenecking
 - depreciation of, 269
 - with different operating lives, 300–305
 - disposal, 1169
 - drawings showing location of plant, 32
 - duplicating for increased production, 110–111
 - eliminating for optimization, 475
 - eliminating or replacing, 17–18
 - fluid flow, 703–708
 - fluid mechanics. *See* Fluid mechanics
 - fouling. *See* Fouling
 - geometry and size for dynamic simulation, 622–624
 - heat transfer. *See* Heat transfer
 - identifying in PFDs, 16–17
 - increasing allyl chloride production, 1384
 - intermediate storage for, 109
 - in multiproduct batch processes, 111–113
 - overview of, 695–696
 - parameter selection for simulation, 405–411
 - PFD topology for, 14–18
 - plant cost estimates. *See* Plant costs
 - problem-solving, 1068
 - process design. *See* Major equipment summary, in product design
 - reactors. *See* Reactors
 - rearranging for optimization, 475–477
 - retrofitting, 1091
 - with same operating lives, 299–300
 - scheduling batch processes, 97–98, 101–106, 490–494
 - summarizing in PFD, 21–23
 - troubleshooting. *See* Troubleshooting
- Equipment, dynamic simulation setup
- dynamic data/specification of, 624
 - dynamic models for, 632–633
 - flash separators and storage vessels, 630–632
 - heat exchangers, 625
 - method of lines, 632
 - process heat exchangers, 627–630
 - reactors, 632
 - series of CSTRs, 632
 - utility heaters/coolers, 625–627
- Equipment, other
- knockout drums. *See* Knockout drums (phase separators)
 - pressure vessels. *See* Pressure vessels
 - steam ejectors. *See* Steam ejectors
- Equipment summary table
- cumene production facility problems, 1425–1426
 - as final element of PFD, 21–22
 - PFD synthesis, 390–391
 - scale-down of phthalic anhydride production, 1409–1410
- Equivalent annual operating cost (EAO)C
- for distillation using McCabe-Thiele method, 900–901
 - for equipment with different operating lives, 302–303
 - for heat-exchanger networks, 534–536
 - for incremental analysis, 309
 - for large processes using HENSAD, 540–541
 - objective functions in optimization, 470–471
- Equivalent capitalized cost (ECC), 301
- Equivalent length method, frictional loss, 710
- Errors, common simulation, 412–413
- Ethanol, purifying with pervaporation, 380–381
- Ethical dilemmas, 1117–1118
- Ethics and professionalism
- affinity to group and mobile truth, 1183–1184
 - business codes of conduct, 1126–1127
 - codes of ethics, 1110–1114
 - duties and obligations, 1110
 - engineer-in-training certification, 1122–1124
 - ethical dilemmas, 1117–1118
 - ethical heuristics, 1118
 - Fundamentals of Engineering (FE) exam, 1122–1124
 - legal liability, 1125–1126
 - moral autonomy, 1105
 - moral values and, 1104
 - nonprofessional responsibilities, 1108–1110
 - Principles and Practice (PE) exam, 1124–1125
 - professional registration (certification), 1121–1125
 - reasons for ethical behavior, 1103–1104
 - reflection in action, 1106–1107
 - registered professional engineer, 1124–1125
 - rehearsal of new skills, 1105–1106
 - resource materials for, 1118–1121
 - whistle-blowing, 1115–1117
- Ethics Resource Guide, NIEE, 1119
- “Ethics Test” video, NSPE code of ethics, 1121
- Ethylbenzene (EB) production
- major equipment summary, 1289–1291
 - making it greener, 1171
 - overview of, 1283–1284
 - process description, 1284
 - process flow diagram, 1286
 - reaction kinetics, 1284–1285
 - references, 1291
 - simulation (CHEMCAD) hints, 1291
 - stream table, 1287–1288
 - utility summary table, 1288
- Ethylene oxide production
- major equipment summary, 1315–1316
 - making it greener, 1171
 - overview of, 1311
 - process description, 1311–1313
 - process flow diagram, 1312
 - reaction kinetics, 1313, 1316
 - references, 1317
 - simulation (CHEMCAD) hints, 1316
 - split-range pressure control of, 673
 - stream table, 1314
 - utility summary table, 1315
- Evaluate step, in troubleshooting, 1068–1071
- Evaluation level, Bloom’s Taxonomy, 4
- Evaporators
- bare module cost for, 1270
 - bare module factors for, 1271
 - calculating utility costs for refrigeration, 225–228
 - equipment cost data for, 1249
 - material factors for, 1272
 - pressure factors for, 1265
 - purchase costs for, 1253
 - separation and, 876
- Evolution, group, 1183
- Exams, team, 1189
- Excel, user-added models, 563
- Exchanger networks. *See* Pinch technology
- Exchangers. *See* Heat exchangers
- Executive summary
- report abstract vs., 1198–1199
 - written report guidelines, 1203–1204
- Exhibits (figures and tables), written communications as, 1200
- Exothermic reactions
- fluidized bed reactors for extreme, 985, 986
 - hierarchy for nonisothermal plug flow reactors, 984–986
 - loss of coolant accidents (LOCAs) in, 1145
 - reactor design and, 373
- Expanders, input for process simulation, 406
- Expansion valve or turbine, utility costs for refrigeration, 225–228
- Experience-based principles, in process design advantages/disadvantages of materials of construction, 357
- heuristics and shortcut methods, 348–349
- heuristics for compressors, fans, blowers, and vacuum pumps, 361
- heuristics for drivers and power recovery equipment, 358
- heuristics for drums (process vessels), 358
- heuristics for heat exchangers, 362
- heuristics for liquid-liquid extraction, 365
- heuristics for packed towers (distillation and gas absorption), 364
- heuristics for piping, 360
- heuristics for pressure and storage vessels, 366
- heuristics for pumps, 360
- heuristics for reactors, 366
- heuristics for refrigeration and utility specifications, 367
- heuristics for thermal insulation, 362
- heuristics for towers (distillation and gas absorption), 363
- heuristics for tray towers (distillation and gas absorption), 364
- maximizing benefits of experience, 349–351
- overview of, 347–348
- physical property heuristics, 355
- process unit capacities, 356
- references, 368
- tables of heuristics and guidelines, 351–355
- Expert systems, select model for system, 402
- Explicit Euler method, dynamic simulation integrator algorithms, 635
- Explicit methods, dynamic simulation integrator algorithms, 635
- Explosions. *See also* Fire and explosions, 1144
- Extended surfaces
- fin efficiency for other fin geometries, 830–831
 - heat transfer coefficients for gases and, 828–829

- rectangular fin with constant thickness, 829–830
- total heat transfer surface effectiveness, 831–837
- Extraction equipment
 - agitated columns, 943–944
 - centrifugal extractors, 943, 945
 - comparison of, 945–946
 - mixer-settlers, 943
 - overview of, 942
 - pulsed columns, 943
 - static and pulsed columns, 943
 - static columns, 943
- F**
- Faculty, outcomes assessment by, 4–6
- Failure Modes and Effects Analysis (FMEA), in Process Hazard Analysis, 1146
- Falling-film condensation
 - on cylinders, 825–828
 - Nusselt's analysis, 824–825
- Fanning friction factor, for frictional losses, 709–711
- Fans
 - bare module cost for, 1270
 - bare module factors for, 1271
 - equipment cost data for, 1249–1250
 - heuristics for, 361
 - increasing pressure of gases, 707
 - material factors for, 1273
 - pressure factors for, 1265
 - purchase costs for, 1254
- Fatal accident rate (FAR), 1132–1133
- Fatality rate, accident statistics, 1132–1133
- Fault diagnosis and identification (FDI), dynamic simulation in, 619
- Fault-Tree Analysis (FTA), in Process Hazard Analysis, 1146
- FBD (Function Block Diagram), logic control, 680
- FCC (Fluidized catalytic cracking), solids modeling, 440
- FCI. *See* Fixed capital investment (FCI)
- FDI (Fault diagnosis and identification), dynamic simulation in, 619
- FE (Fundamentals of Engineering) exam, 1122–1124
- Feasible distillation processes, ternary azeotropic distillation, 382, 386–388
- Federal government regulations
 - health, safety and environment, 1134
 - industry and commerce, 1126
- Federal Insecticide, Fungicide, and Rodenticide Act (FIFRA), 1161
- Federal Register (FR), 1126, 1134
- Feed chemicals/feed streams
 - additions for stabilization or separation, 67
 - affecting reflux ratio in separation, 897–898
 - formulating preliminary PFD for, 78–82
 - in generic block flow process diagram, 63–64
 - improving environment with green, 1163–1164
 - inert materials controlling equilibrium reactions, 67–68
 - input/output process diagrams and, 68–69
- McCabe-Thiele method for distillation, 892–894
- non-stoichiometric feed compositions of special concern, 154
- performance of feed section to process, 751–755
- preparing reactor and separator in PFD synthesis, 388–389
- in process concept diagram, 60–61
- in process flow diagram, 61–63
- purifying, 66–67
- reactors transforming into products, 137
- recycling with or without purge stream, 73–75
- selecting feedstream properties for simulation, 404–405
- simulation of toluene HDA process, 427–428
- using continuous vs. batch processes for, 56–58, 60
- Feed-forward control
 - calculator blocks in simulation as, 572
 - combination feedback and, 667
 - major process control loops and, 390
 - model of higher education as, 1–2
 - oral communication as type o, 669
 - ratio control as type of, 669
 - and regulation, 665–667
 - weakness of, 1
 - written communications as, 1209
- Feed preheater, utility cost estimate for, 238–240
- Feed pumps, cumene production facility and, 1419
- Feedback control
 - advantages/disadvantages of, 663
 - basis of, 659
 - examples of, 663–665, 667
 - flowrate schemes for pumping liquids, 675
 - loops for binary distillation column, 685
 - oral presentations provide type of, 1209
 - outcomes assessment analogous to, 1
 - in process control, 640
- Fees, in estimating bare module costs, 201
- Ferrous alloys, selecting materials of construction, 194–197
- Fiduciary responsibilities, business codes of conduct, 1127
- FIFRA (Federal Insecticide, Fungicide, and Rodenticide Act), 1161
- Figures (graphs and pictures), in design reports, 1200, 1206–1207
- Film boiling, heat transfer coefficients for, 822–824
- Film heat transfer coefficients
 - boiling heat transfer. *See* Boiling heat transfer coefficients
 - condensing heat transfer, 824–828
 - correlations for, 803
 - flow inside tubes, 803–808
 - flow outside of tubes (shell-side flow), 808–813
- Filters
 - bare module factors for, 1274
 - cost curves for purchased equipment, 1262
 - equipment cost data for, 1250
- L-phenylalanine and L-aspartic acid production, 1328
- for particles in compressors, 708
- Finned tubes, air-cooled heat exchangers, 797
- Fins
 - effectiveness for rectangular fins, 864–866
 - efficiency of rectangular fins with constant thickness, 828–829
 - other fin geometries, 830–831
 - total heat transfer surface effectiveness and, 831–837
 - various types of, 829
- Fire and explosions
 - Dow Fire & Explosion Index, 1150–1152
 - pressure-relief systems, 1145
 - terminology, 1143–1145
- Fired heaters. *See* Furnaces
- Firm estimates, 172–174
- First person pronouns, avoiding in written design reports, 1202
- Fixed capital investment (FCI)
 - calculating total capital investment, 269
 - calculating utility costs, 221
 - cash flow diagram for new project, 286
 - depreciation of, 269
 - estimating EAO for HENs, 534–536
 - estimating manufacturing costs, 215, 217, 230–231
 - interest rate nondiscounted profitability criteria and, 287–291
 - Monte-Carlo analysis for quantifying risk, 321–322
 - sensitivity analysis for quantifying risk, 316–318
 - in single-variable optimization, 480
 - supply and demand curves affecting, 313
 - in two-variable optimization, 483
- Fixed manufacturing costs, 214–218
- Fixed-tubesheet design, S-T heat exchangers, 783–784, 788
- Fixing problems, in troubleshooting, 1066
- Flanges
 - connecting pipes with, 705
 - minimizing pollution from leaking, 1166
- Flares, in pressure-relief systems, 1145
- Flash point, of liquid, 1144
- Flash separators, dynamic simulation and, 630–632
- Flash units, equipment parameters in PFD synthesis, 408
- Flexibility
 - optimization related to, 489–490
 - process flow diagram, 489–490
 - using continuous vs. batch processes, 57
- Flooding
 - calculating diameter for packed tower, 930–931
 - calculating velocities, 915–916
 - in mist eliminators, 1038–1040
 - overview of, 914–915
- Flow. *See also* Fluid mechanics
 - analyzing pump and system curves, 743–749
 - base-case ratios, 736–739
 - compressor curves and staging, 749–752
 - frictional pipe. *See* Frictional pipe flow

- Flow. *See also* Fluid mechanics (*continued*)
 inside tubes, film heat transfer coefficients, 803–808
 net positive suction head (NPSH) for pumps, 739–743
 over tubes, film heat transfer coefficients, 808–813
 past submerged objects, 723–728
 patterns on shell-side of S-T heat exchangers, 785–788
 performance of fluid flow equipment, 736
 through fluidized beds, 728–730, 999–1004
- Flow diagrams
 block flow diagrams. *See* Block flow diagrams (BFDs)
 piping and instrumentation diagrams. *See* Piping and instrumentation diagrams (P&IDs)
 process flow diagrams. *See* Process flow diagrams (PFDs)
 value in communicating information, 9
- Flow summary table
 information in PFDs for, 19–20
 PFD synthesis and, 390
- Flowrate
 for binary distillation column, 685–687
 changing with valves, 655
 complex problems for reactors, 1004–1006
 exchanging heat between process streams and utilities, 678
 increasing pressure, and regulating, 674–676
 measurement, 730–735
 measuring, 662, 730–735
 performance curves for, 744–746, 748–750
 performance of feed section, 752–755
 regulating by manipulating, 655–656
 regulating pressure and, 660–662
 regulating with valves, 705
- Flowsheet builder, simulators, 997
- Flowsheet solver, simulators, 997
- Flowsheets
 of chilled methanol in acid-gas removal, 572–573
 in flow summary table for PFD synthesis, 390
 handling recycle streams, 413–415
 optimization using decision variables, 484–487
 process simulation with topology input for, 404
 selecting topology for PFD synthesis, 404
 simulation of toluene HDA process, 427
 steady-state simulation examples, 580–585
 using tear streams in sequential modular approach, 576–578
 using tear streams to solve problems with recycles, 400–401
- Flowshop plants, batch processes in, 101–103
- Fluid flow equipment, performance
 base-case ratios, 736–739
 compressor curves, 749–752
 feed section to process, 751–755
 net positive suction head (NPSH) for pumps, 739–743
 overview of, 736
 pump and system curves, 743–749
- Fluid mechanics
 analyzing pump and system curves, 743–749
 base-case ratios, 736–739
 basic relationships in, 697–703
 compressor curves and staging, 749–752
 compressors, 707–708
 flow past submerged objects, 723–728
 flowrate measurement, 730–735
 fluid flow equipment performance, 736
 fluid flow equipment types, 703–708
 fluidized beds, 728–730
 force balance, 703
 frictional pipe flow. *See* Frictional pipe flow
 mass balance, 698–699
 mechanical energy balance, 700–703
 net positive suction head (NPSH) for pumps, 739–743
 overview of, 697
 performance of feed section to process, 751–755
 pipes, 703–705
 pumps, 706–707
 valves, 705–706
- Fluidized bed reactors
 bubbling fluidized bed, 999–1000
 designing new facility for allyl chloride production, 1394
 for extreme exothermic reactions, 985
 fast fluidization, 1001
 flow through, 728–730
 increasing allyl chloride production, 1388–1393
 overview of, 999
 turbulent fluidization, 1000–1001
- Fluidized catalytic cracking (FCC), solids modeling, 440
- Fluids
 flow of. *See* Flow
 S-T heat exchanger heuristics, 788–789
- FMEA (Failure Modes and Effects Analysis), in Process Hazard Analysis, 1146
- Fogler and LeBlanc, problem-solving strategy, 1068–1071
- Fonts, improper use in oral presentations, 1217
- Force balance
 and flow around submerged objects, 723–728
 fluid flow in piping systems, 703
- Forced convection, effects on pool boiling, 817–822
- Forecasting uncertainty
 in chemical processes, 310–311
 supply and demand factors, 311–314
- Foreign countries, business codes of conduct for, 1127
- Formal oral presentations, preparing for, 1210–1211
- Formalin production
 defined, 1317
 major equipment summary, 1321–1323
 making it greener, 1171
 process description, 1317–1319
 process flow diagram, 1318
 reaction kinetics, 1319
 references, 1319
 simulation (CHEMCAD) hints, 1319
- stream table, 1320
 utility summary table, 1321
- Formation stage, in group evolution, 1184
- Formats
 written communication, 1197
 written report guidelines, 1203–1206
- Forming stage, in group evolution, 1184
- FORTTRAN programming language, user-added models, 563
- Fouling
 antifouling chemicals, 223
 bubble caps prone to, 913
 and choice of tube-side fluid, 788
 condensing heat transfer and, 824
 design algorithm for S-T heat exchangers, 839, 841
 design away from pinch and, 520–521
 equipment, 59
 estimating individual heat transfer coefficients and, 803
 and heat transfer coefficients, 800–801
 optimum cycle time for cleaning heat exchangers prone to, 497
 in separation equipment, 938–940
 troubleshooting performance, 1070
 water contaminants in steam production causing, 229
- FR (Federal Register), 1134
- Free convection boiling, 813
- Friction (interpersonal), sources of group, 1180–1181
- Frictional losses, calculating, 709–711
- Frictional pipe flow
 calculating frictional losses, 709–711
 choked flow, 720–723
 compressible flow, 719–720
 incompressible flow, 712–719
- Friendship, choosing group members, 1183
- FTA (Fault-Tree Analysis), in Process Hazard Analysis, 1146
- Fuel costs. *See* Utility costs
- Fugitive emissions
 minimizing pollution from, 1166
 regulation of, 1140–1142
- Fully developed turbulent flow
 friction factors in choked flow, 721–723
 frictional losses for, 710
- Function Block Diagram (FBD), logic control, 680
- Fundamentals of Engineering (FE) exam, 1122–1124
- Furnaces
 bare module cost for, 1270
 bare module factors for, 1271
 equipment cost data for, 1250
 material factors for, 1273
 pressure factors for, 1265
 purchase costs for, 1255
- Future liability
 in economics of pollution prevention, 1168
 estimating fate of chemicals in environment, 1163
- Future value (F) of investment
 calculating annuities, 261–265

- overview of, 249
 - types of interest used when calculating, 251–253
- G**
- Gantt charts
- in batch processing, 97–98
 - group scheduling and, 1185
 - multiproduct sequence, 103
 - reference for developing and using, 1191
 - and scheduling, 97–98
 - scheduling batch processes, 103–105
 - for single-product and multiproduct campaigns, 104–105
- Gas
- absorption, 363
 - heat transfer coefficients in packed beds, 992–993
 - law. *See* Ideal gas law
 - permeation membrane separations, 947–950
- Gas-liquid separations
- two-film model for, 879–880
 - using mass separating agents, 903
- Gas-phase reactions
- estimating concentrations using ideal gas law, 963–964
 - exothermic vs. endothermic, 373
 - justifying reactors/separators operating at conditions of special concern, 152–154
 - operating reactors and separators outside pressure range of special concern, 163
 - reactor design for PFD synthesis, 373
 - reactors operating at conditions of special concern, 154
 - reasons for multiple reactors, 76
- Gas-solid reactor configuration, fluidized beds, 999–1004
- Gasifiers, modeling downward-flow/oxygen blown/entrained-flow
- major equipment summary, 1375
 - overview of, 1371
 - process description, 1371–1373
 - reaction kinetics, 1373–1375
 - references, 1377
 - simulation (Aspen Plus) hints, 1375–1377
 - stream table, 1374–1375
- Gate valves, controlling fluid flow, 705–706
- Gauss-Legendre method, as multistep integrator, 636
- Gear's method, as multi-step integrator, 636
- General duty clause, OSHA Act, 1126, 1135
- General expenses, cost of manufacturing, 214–218
- Generate step, process troubleshooting, 1069–1071
- Generic block flow diagrams (GBFDs)
- as intermediate step between process concept and PFD, 63–65
 - synthesizing PFD from. *See* Synthesis of PFD, from BFD
- Generic model control, advanced process control, 683
- Geometry of equipment, in dynamic simulation, 622–624
- Gibbs free energy
- calculating for electrolyte systems, 430, 445–447
 - solids modeling and, 442
- “Gilbane Gold” video, ethics, 1118, 1121
- Glass, advantages/disadvantages of, 356
- Global optimum
- defined, 464
 - finding, 468
- Globalization
- of chemical industry, 123–124
 - steady-state simulation for competitive advantage, 562
- Globe valves, for regulation, 658, 705–706
- Grade-level, horizontal, in-line arrangement (plant layout), 34, 36
- Grade-point average, choosing group members, 1182
- Graetz number, heat transfer coefficients for laminar flow, 806–809
- Grammar checkers, imperfect for formal written work, 1215–1216
- Grammar, written report guidelines, 1202–1203
- Graphical representations
- of flooding limit, 919, 929
 - McCabe-Thiele diagram for distillation, 888–896
 - packed columns, 902
- Graphics
- guidelines for oral presentations, 1211–1212
 - mixing text visuals with, 1211
 - using colors and exotic features in, 1217
- Graphs
- common mistakes in presentation, 1229
 - corrected version for presentation, 1230
 - in design reports, 1200
 - report guidelines, 1206–1207
- Grassroots (green field), vs. total module costs, 201–203
- Gravity, L-L separation, 1044–1047
- Green chemistry, 1163–1164
- Green engineering
- economics of pollution prevention, 1167–1168
 - environmental fate of chemicals, 1160–1163
 - environmental regulations, 1159–1160
 - green chemistry, 1163–1164
 - life cycle analysis in, 1168–1169
 - overview of, 1159
 - PFD analysis for pollution/environmental performance, 1166–1167
 - pollution prevention during process design, 1164–1166
- Gross profit margin, base costs in optimization, 471
- Groups
- assessing and improving effectiveness of, 1178–1180
 - coordinated energy of, 1177–1178
 - editing reports for consistency, 1203
 - forming stage, 1184
 - increased efficiency (synergy) of, 1176
 - norming stage, 1185–1186
 - organizational behaviors and strategies in, 1180–1184
 - performing stage, 1186
 - storming stage, 1184–1185
 - team building from, 1186–1187
 - teams as subsets of, 1175
 - work environment in effective, 1177
- Groupthink, 1184
- Guide words, HAZOP, 1147
- H**
- Hazard assessment, in Risk Management Plan, 1142
- Hazard Communication Standard (HazCom), 1136–1138
- Hazardous air pollutants (HAP), 1141
- Hazardous Substances Data Bank (HSDB), 1135
- Hazardous waste
- green chemistry minimizes, 1163–1164
 - Resource Conservation and Recovery Act (RCRA), 1161
 - source reduction minimizing, 1159–1160
- Hazardous Waste and Emergency Operations (HAZWOPER) rule, OSHA, 1142
- Hazards and operability study (HAZOP)
- identifying potential industry standards, 1133
 - process hazards analysis technique, 1146–1147
- HCl absorber, process simulation, 402–403
- Headers, utility streams supplied via, 655
- Heads (end sections), pressure vessel design, 1022, 1023–1024
- Health, safety, and environment (HSE)
- accident statistics, 1132–1133
 - chemical engineer's role in, 1134
 - Chemical Safety and Hazard Investigation Board, 1153
 - Dow Chemical Hazards index, 1153
 - Dow Fire & Explosion Index, 1147, 1150–1152
 - fires and explosions, 1143–1145
 - fugitive emissions, 1141
 - glossary of acronyms for, 1154–1156
 - Hazard and Operability Study (HAZOP), 1146–1149
 - Hazard Communication Standard (HazCom), 1136–1138
 - inherently safe design strategy, 1153–1154
 - overview of, 1131
 - planned emissions, EPA, 1140–1141
 - pressure-relief systems, 1145
 - Process Hazard Analysis (PHA), 1142, 1145–1146
 - Registration, Evaluation, Authorization and Restriction of Chemicals (REACH), 1137
 - risk assessment, 1131–1134
 - Risk Management Plan (RMP), 1141–1142
 - worse-case scenarios, 1133–1134
- Health, safety, and environment (HSE), regulations and agencies
- EPA, 1140–1142
 - Internet addresses for federal agencies, 1134
 - list of acronyms for, 1154–1156
 - nongovernmental organizations, 1143–1144
 - OSHA and NIOSH, 1135–1140
 - overview of, 1134–1135
 - Process Safety Management (PSM), 1138–1140

- Heat
- exchanging between process streams, 679
 - exchanging heat/work between process streams/utilities, 676–678
 - justifying operations outside temperature range for, 151–152
- Heat capacity
- building model of distillation column for electrolyte system, 448
 - gathering physical property data for PFD design, 371
 - modeling electrolyte systems, 431–432
 - simulation of, 416
 - standard-state, 431
- Heat duty
- calculating for condensers/reboilers, 899, 924–925
 - calculating using energy balance, 877, 885, 887
- Heat-exchanger network synthesis analysis and design (HENSAD) program, 540–541
- Heat-exchanger networks (HENs)
- composite enthalpy curves for systems without a pinch, 524–525
 - composite enthalpy curves to estimate heat-exchanger surface area, 525–529
 - composite temperature-enthalpy diagram for, 523–524
 - constructing cascade diagram, 514–516
 - cost comparisons, 512–513
 - design, 517–523
 - formulating PFD for, 83
 - mass-exchange networks vs., 541–542
 - minimum approach temperature for, 513
 - minimum number of heat exchangers for, 516–517
 - pinch or pinch point in, 509–510
 - temperature interval diagram for, 513–514
- Heat exchangers. *See also* Shell-and-tube (S-T) heat exchangers
- adjusting overall heat transfer coefficient for, 679
 - analyzing conditions of special concern for, 164
 - bare module and material factors for, 1267–1271
 - capacities of process units in common usage, 356
 - cocurrent flow, 773–775
 - condensers/reboilers in distillation columns as, 923–924
 - conditions of special concern for, 155–158
 - countercurrent flow, 771–773
 - design algorithm, 838–840
 - design algorithm examples, 840–846
 - design cumene production at new facility, 1432
 - design equation for, 773
 - design for pressure drop, 837–838
 - dynamic models for, 625
 - dynamic simulation of process, 627–630
 - effectiveness charts, 861–864
 - equipment cost data for, 1250
 - exchanging heat between process streams and utilities, 676–678
 - heat transfer coefficients. *See* Heat transfer coefficients
 - heuristics for, 362
 - input for process simulation, 406–407
 - nonlinear Q vs. T curves in, 776–777
 - overall heat transfer coefficient varies with, 777–778
 - performance problems and, 846–850
 - physical property data for PFD synthesis, 371
 - pressure factors for, 1265–1266
 - purchase costs for, 1256
 - streams with phase changes, 775–776
- Heat exchangers, equipment design
- baffles, 784–786
 - fixed tubesheet/floating tubesheets, 783–784
 - shell and tube partitions, 784
 - shell-and-tube (S-T), 779–783
 - shell-and-tube (S-T) heuristics, 788–789
 - shell-side flow patterns, 785–788
- Heat exchangers, performance
- overview of, 846–847
 - problems, 846–850
 - problems, using worked examples, 850–859
 - sizes of standard tubes in, 800, 802–803
 - thermal conductivity and, 800–802
 - in tray and packed towers, 933–934
 - using ratios to determine, 847–850
- Heat flux, 813–816
- Heat integration
- designing heat-exchanger network using, 517–523
 - minimum approach temperature for, 513
 - minimum number of heat exchangers for, 516–517
 - network design for, 510–513
 - pollution prevention using, 1165
 - temperature interval diagram for, 513–516
- Heat sensitivity, separation units for PFD synthesis, 376
- Heat transfer
- algorithms, and heat exchanger design for, 837–846
 - baffles used in, 784–786
 - in cocurrent heat exchangers, 773–775
 - coefficients. *See* Heat transfer coefficients
 - cost for hot circulating fluids in, 234
 - in countercurrent heat exchangers, 771–773
 - CSTR configurations for, 980–984
 - equipment design. *See* Heat exchangers, equipment design
 - extended surfaces for, 828–837
 - fin effectiveness and, 864–866
 - fixed tubesheets and floating tubesheets in, 783–784
 - heat exchanger effectiveness charts and, 861–864
 - heuristics for shell-and-tube exchanger designs, 788–789
 - increasing allyl chloride production, 1384–1385
 - increasing endothermic reactions in reactors, 984–986
 - LMTD correction factors. *See* LMTD correction factors
 - matching volume in S-T reactors and, 997–999
 - nonlinear Q versus T Curves, 776–777
 - overall heat transfer coefficients, 777–778, 798–800
 - overview of, 771
 - performance problem examples, 850–859
 - performance problems and, 846–850
 - role in reactor design, 990–991
 - in streams with phase changes, 775–776
- Heat transfer coefficients. *See also* Overall heat transfer coefficient (U)
- adjusting for heat exchanger, 679
 - boiling heat transfer for maximum heat flux in pool, 815–816
 - boiling heat transfer for typical boiling curve, 813–815
 - boiling heat transfer in film boiling, 822–824
 - boiling heat transfer in forced convection, 817–822
 - boiling heat transfer in nucleate (pool) boiling, 816–817
 - calculating in nonisothermal PFRs, 992–993
 - condensing heat transfer, 824–828
 - flow inside tubes, 803–808
 - flow outside of tubes (shell-side flow), 808–813
 - for gases. *See* Extended surfaces
 - performance problems for reactors, 1005
 - regulation scheme for Cumene reactor, 684–685
 - resistances due to fouling, 800–801, 803
 - resistances in series, 798–800
 - thermal conductivities of metals and tubes and, 800–803
- Heaters
- bare module cost for, 1270
 - bare module factors for, 1271
 - capacities of process units in, 356
 - conditions of special concern for, 155–158
 - equipment cost data for, 1250
 - estimating utility costs from PFDs, 238–240
 - material factors for, 1273
 - pressure factors for, 1266
 - purchase costs for, 1255
- Heating loops
- configurations for heat removal from CSTRs, 980–981
 - incremental analysis of design oversight in, 306–307
 - in maximum flow rate for Dowtherm A, 1085–1091
- Height equivalent to theoretical plate (HETP), calculating height of packed tower, 929–930
- “Henry’s Daughters” video, ethics, 1118, 1121
- Henry’s Law
- applying to model of distillation column for electrolyte system, 448
 - calculating tray efficiency, 921–922
 - estimating fate of chemicals in environment, 1163
 - hybrid thermodynamic systems and, 423
 - liquid-liquid separations, 878
 - modeling aqueous electrolyte system, 437
 - modeling electrolyte system, 430

- HENSAD (Heat-exchanger network synthesis analysis and design) program, 540–541
- HENSs. *See* Heat-exchanger networks (HENSs)
- Heptenes production
 overview of, 1344–1345
 preliminary equipment summary, 1347–1350
 process description, 1351
 reaction kinetics, 1351, 1353
 references, 1352
 simulation (CHEMCAD) hints, 1352
 stream table, 1346
 utility summary table, 1350
- HETP (Height equivalent to theoretical plate), calculating height of packed tower, 929–930
- Heuristics
 benefits of experience in creating new, 349–351
 for compressors, fans, blowers, and vacuum pumps, 361
 for drivers and power recovery equipment, 358
 ethical. *See* Heuristics, ethical
 four characteristics of, 1103
 guidelines for applying, 351–355
 for heat exchangers, 362
 for liquid-liquid extraction, 365
 for packed towers (distillation and gas absorption), 364
 physical property-related, 355
 for pipe sizes in 3-D plot plan, 37–38
 for piping, 360
 for pressure and storage vessels, 359
 for process vessels (drums), 358
 for pumps, 360
 for reactors, 366
 for refrigeration and utility specifications, 367
 for S-T heat exchangers, 788–789
 shortcut methods and, 348–349
 for thermal insulation, 362
 for towers (distillation and gas absorption), 363
 for tray towers (distillation and gas absorption), 364
 when to purify feed, 66–67
- Heuristics, ethical
 developing new, 1118
 duties and obligations, 1110
 ethical dilemmas and, 1117–1118
 for mobile truth, 1108
 moral autonomy of engineers, 1105
 reflection in action, 1107
- Hierarchy
 in conceptual process design, 55–56
 endothermic reactions in nonisothermal PFRs, 986
 exothermic reactions in nonisothermal PFRs, 984–986
- Histograms (bar charts)
 in design reports, 1200
 Monte-Carlo analysis for quantifying risk, 322
- HiTec molten salt, phthalic anhydride production, 1404, 1407, 1414
- Holding-in-place method, intermediate storage, 108
- Horsepower, determining pump, 701–702, 713–714
- Hot circulating heat transfer fluids, utility costs for, 234
- Hot spots, reactor, 988–989
- Hourly wage, labor cost of manufacturing, 218–219
- HSDB (Hazardous Substances Data Bank), 1135
- HSE. *See* Health, safety, and environment (HSE)
- Human machine interface (HMI), OTS system, 43–45
- Hurdle rates, acceptable returns from investments, 298–299
- Hybrid systems, thermodynamic models, 423
- Hydraulic equations, MERSHQ for, 436–440
- Hydrogen
 determining profit margin, 68–69
 excess reactant in feed, 162–164
 tracing primary chemical pathways for, 140–142
- Hydrogen sulfide (H₂S)
 conversion to elemental sulfur. *See* Claus unit design, converting H₂S to elemental sulfur
 removal from syngas. *See* CO₂ and H₂S removal from coal-derived syngas
- I**
- Icons, identifying process equipment in PFDs, 16–17
- Ideal gas law
 for applications involving gas permeation, 883
 determining vapor density, 917, 931
 estimate concentrations in gas-phase reactions, 963–964
 learning for process calculation, 1105
- Ideas, in chemical product design, 124–125, 127–128
- IDLH (Immediately dangerous to life and health), air contaminant exposure, 1136
- IGCC (Integrated Gasification Combined Cycle) coal-fed power plant., 44
- Ignition energy, 1144
- IL (Instruction List), logic control, 680
- IMC-based tuning rule, process control, 642–643
- Immediately dangerous to life and health (IDLH), air contaminant exposure, 1136
- Immersive training simulator (ITS)
 linking with OTS systems, 46–48
 overview of, 45
- Impact analysis, in life cycle analysis, 1168
- Impeller, of centrifugal pumps
 overview of, 706–707
 performance analysis of fluid flow for, 744, 748–749
- Implement step, in troubleshooting, 1068–1071
- Implicit Euler method, dynamic simulation, 635
- Implicit methods, dynamic simulation, 635
- Improvement analysis, in life cycle analysis, 1168
- Impurities, considering when to purify the feed, 66–67
- In-process recycle, Pollution Prevention Act of 1990, 1160
- Incidence rate, OSHA accident statistics, 1132–1133
- “Incident at Morales” video, ethics, 1118, 1121
- Incompressible flow
 in packed beds, 711
 in single-pipe systems, 712–719
- Incremental economic analysis
 comparing large projects in, 295–297
 discounted methods in, 308–309
 nondiscounted methods in, 305–308
 objective functions in optimization, 470
 retrofitting facilities using, 305–309
- Incremental net present value (INPV), in incremental analysis, 308–309
- Incremental payback period (IPBP), in incremental analysis, 305–308
- Inequality constraints, in optimization, 464
- Inerts, recycling, 76–77
- Inflation
 cost estimate classifications for, 172
 effect of time on purchased equipment cost, 179–180
 estimating plant costs based on capacity, 206–208
 using CEPCI to account for changes due to, 183–184
- Information
 determining from input/output process diagram, 68–69
 needed in PFD synthesis, 370–371
- Information flags
 adding stream information to PFD with, 21–23
 formulating PFD for, 83
 guidelines for data on, 23–26
- Information (input data), for simulators
 case study, 426–428
 chemical component selection, 401
 common errors, 412–413
 convergence criteria selection, 411–412
 equipment parameter selection, 405–411
 feed stream property selection, 404–405
 flowsheet topology selection, 404
 physical property model selection, 401–404
- Informative executive summaries, 1198–1199
- Initialization step, dynamic simulation, 634
- Inlet pressure, performance analysis of pumps using NPSH, 741
- Input devices, Ladder Diagram (LD), 680–681
- Input/output structure
 feed purity/trace components in, 66–67
 feeds to stabilize/separate products, 67
 formulating preliminary process flow diagram, 79–80
 in generic block flow diagrams, 63–65
 inert feeds to control equilibrium reactions, 67–68
 inert feeds to control exothermic reactions, 67
 information determined by, 68–69
 in process concept diagrams, 60–61
 in process flow diagrams, 61–63
 solving troubleshooting problems, 1069–1071
 troubleshooting/debottlenecking, 1066–1067
 troubleshooting packed-bed absorber, 1072–1074

- Input variables (or inputs)
 in dynamic simulation, 617
 in steady-state simulation, 619–622
- INPV (Incremental net present value), in
 incremental analysis, 308–309
- Instruction List (IL), logic control, 680
- Instruments, constructing P&IDs, 27–30
- Integrated Gasification Combined Cycle (IGCC)
 coal-fed power plant., 44
- Integrated Risk Information System (IRIS), for
 chemical hazards, 1135
- Integrator algorithms, dynamic simulation,
 635–639
- Intensification, of not using hazardous
 materials, 1153
- Intention, HAZOP use of, 1147
- Interactions, group friction from
 uncomfortable, 1181
- Interest rate criterion
 discounted profitability, 293–295
 evaluating profitability, 288
 nondiscounted profitability in project
 evaluation, 288–291
- Interest rates
 affecting supply and demand curves, 313
 calculations from cash flow diagrams, 259–260
 changing over time, 253
 determining for annuity, 261–265
 in discrete cash flow diagram, 256–258
 time basis for compound interest
 calculations, 254–255
 type of, 251–253
- Intermediate storage, for batch processes, 108–110
- Internal devices, Ladder Diagram (LD), 680–681
- Internal model control, 683
- International chemical safety card, for
 hazardous materials, 1136
- Internet addresses
 citing material from, 1200
 for federal agencies, 1134–1135
- Introduction, written report
 example, 1231
 guidelines for, 1204
 improving, 1233
- Inventory, product
 changing during single-product campaign
 run, 107
 in life cycle analysis, 1168
- Investments
 cumulative cash flow diagram for, 258–259
 defined, 249
 depreciation of capital, 268–274
 discrete cash flow diagram for, 256–258
 and time value of money, 248–251
- Investors
 defined, 249
 discrete cash flow diagram for, 256–258
- Ionic reactions, in electrolyte systems
 chemical equilibrium, 432
 modeling aqueous electrolyte system, 435–440
 modeling distillation column, 447, 449
- IPBP (Incremental payback period), in
 incremental analysis, 305–308
- IRIS (Integrated Risk Information System), for
 chemical hazards, 1135
- Isentropic work in compressors, 750–752
- Isopropyl alcohol. *See* Acetone production from
 isopropyl alcohol
- Isopropyl benzene. *See* Cumene
- Isothermal flow, friction factors, 719–721
- Isothermal work, in compressors, 750–752
- Iterations, creating multiple report, 1196
- ITS (Immersive training simulator)
 linking with OTS systems, 46–48
 overview of, 45
- J**
- Jacobian matrix
 applying to thermodynamic properties, 563
 Broyden's method and, 582
 defined, 564
 direct substitution and, 578
 equation-oriented (EO) approach and, 585
 Newton's method and, 589–592
 Wegstein's method and, 579–580
- Jobshop plants, batch processing in, 103–106
- Just-in-time (JIT) manufacturing, inherently safe
 design, 1153
- K**
- K-factor. *See* Phase equilibrium
- Kern's method
 estimating shell-side heat transfer, 809–811
 Kern's method for shell-side heat transfer,
 811–813
- Kinetic reactors
 CSTR and plug flow reactors as, 408
 data in PFD synthesis, 370–371
 designing, 372
 justifying conditions of special concern in
 reactors using PFD, 159–162
- Kinetics
 developing user kinetic models, 568–571
 of mechanical energy balance in piping
 systems, 700–703
 reaction kinetics, 159–164, 370–371, 405
 reactor design and, 962–964
 resource materials for, 84
- Knockout drums (phase separators)
 compressors and, 708
 conditions of special concern for, 164
 L-L separation, 1044–1049
 mist eliminators and other
 internals, 1036–1044
 purpose of, 1015, 1024
 as separation equipment, 911
 V-L separation, 1025–1028
 V-L separation design,
 horizontal, 1032–1035
 V-L separation design, vertical, 1029–1032
- Knowledge level, Bloom's Taxonomy, 3
- Kremser equation, for dilute solutions, 905–911
- L**
- L-aspartic acid. *See* L-phenylalanine and
 L-aspartic acid, batch production
- L-H (Langmuir-Hinshelwood) kinetics
 basic form of, 962–964
 simulating reactions with kinetic reactors, 408
- L-L. *See* Liquid-liquid (L-L) separation
- L-L-V separators, 1046, 1048–1049
- L-phenylalanine and L-aspartic acid, batch
 production
 overview of, 1323
 process description, 1323
 process flow diagram, 1324
 reaction kinetics, 1325–1329
 references, 1229
- Labor costs
 affecting supply and demand curves, 313
 in cost of manufacturing, 214–217
 in manufacturing cost estimates, 218–219
- Labor needs, deciding on continuous vs. batch
 processes, 58
- Ladder Diagrams (LDs), logic control, 680–682
- Land, cannot be depreciated, 269
- Lang Factor method, estimating plant cost, 184
- Langmuir-Hinshelwood (L-H) kinetics
 basic form of, 962–964
 simulating reactions with kinetic reactors, 408
- Large projects, incremental economic analysis
 for, 295–297
- Large temperature driving force, in exchanger,
 988–989
- Latent heat, 892–893
- Lattice search, vs. response surface
 techniques, 489
- Laws
 legal liability of chemical engineers,
 1125–1126
 protecting whistle-blowers, 1115
- LCA (Life cycle analysis), in green engineering,
 1168–1169
- LDs (Ladder Diagrams), logic control, 680–682
- Le Chatelier's principle, for equilibrium
 reaction, 965
- Leaching, as solid-liquid separation, 876
- Leadership, group, 1181–1182, 1184
- Leading Self-Directed Work Teams* (Fisher), 1191
- Leaking equipment
 makeup water in steam production due to, 228
 minimizing pollution from, 1166
- Learning, in teams, 1182, 1189–1190
- Legal liability, of chemical engineers, 1125–1126
- Leidenfrost point, heat transfer for pool boiling
 curve, 814
- LEL (lower explosive limit), 1144
- Letter of transmittal, report format, 1203
- LFL (lower flammability limit), 1144
- Liability, pollution prevention economics and
 future, 1168
- Licensed professional chemical engineer
 engineer-in-training (EIT), 1122–1124
 Principles and Practice (PE) exam, 1124–1125
 professional registration, 1121–1122
 reasons to become, 1121–1122
- Life cycle analysis (LCA), in green engineering,
 1168–1169
- Life of equipment, depreciation and, 269
- Linear equation solvers, 637–639
- Linear programming, 464
- Linear quadratic control (LQC), 683
- Linear valves, in flowrate control, 658
- Linking ITS with OTS, 46–48
- Liquid level, measuring process variables, 662

- Liquid-liquid equilibrium (LLE)
 building model of distillation column for electrolyte system, 448
 hybrid systems and, 423
 liquid-state activity-coefficient models, 419–423
 thermodynamic model solver, 399
- Liquid-liquid (L-L) separation
 energy balances, 877
 heuristics for liquid-liquid extraction, 365
 input for process simulation, 411
 with knockout drums, 1044–1048
 two-film model for, 879–880
 using mass separating agents, 903
- Liquid-liquid-vapor (L-L-V) separators, 1046, 1048–1049
- Liquid-phase reactions, CSTRs used for, 980–984
- Liquid-solid reactor configurations, fluidized beds, 999–1004
- Liquid-state activity-coefficient models
 hybrid systems and, 423
 overview of, 419–423
 phase equilibrium model, 419–422
- Liquids, pumps used to transport, 706
- LLE. *See* Liquid-liquid equilibrium (LLE)
- LMTD correction factors
 background, 789–790
 for cross-flow exchangers, 797
 for flash separators and storage vessels, 630–632
 heat-exchanger effectiveness charts, 861–864
 for linear/nonlinear equation solvers, 639
 for multiple S-T-pass exchangers, 793–797
 and phase changes, 797–798
 simulation errors, 413
 for single-pass, double-tube pass (1-2) exchanger, 790–793
 for utility heaters/coolers, 626–627
- LMTD (log-mean temperature difference)
 for cocurrent vs. countercurrent flow, 774–775
 in countercurrent flow, 773
 nonlinear Q vs. T curves and, 776–777
 streams with phase changes, 775–776
- Loading, as precursor to flooding, 915
- Local optimum, defined, 464
- Local truncation error (LTE), in dynamic simulation, 636–637
- Log-mean temperature correction factor (*F*)
 for all exchangers, 529–534
 for design away from pinch, 521
- Log-mean temperature difference. *See* LMTD (log-mean temperature difference)
- Logic control, in control system design, 680–682
- Logic ladder diagrams, 32
- Longitudinal pin fin constant thickness, 829
- Loss control credit factors, Dow Fire & Explosion Index, 1151–1152
- Low-alloy steels, materials
 of construction, 194–197
- Lower explosive limit (LEL), 1144
- Lower flammability limit (LFL), 1144
- Lower-level controllers, as SISO controllers, 640
- LQC (linear quadratic control), 683
- LSSQP approach, to steady-state simulations, 588–589
- LTE (local truncation error), in dynamic simulation, 636–637
- Lumped-parameter models, 625
- M**
- MAC (model algorithmic control), 683
- Mackay Level III model, 1166–1167
- MACRS (modified accelerated cost recovery system) depreciation allowances
 current federal tax law based on, 273–274
 designing new cumene production facility, 1430, 1432
 profitability criteria for project evaluation, 289
 report-writing case study, 1222
- Maintenance
 selecting continuous vs. batch processes, 58
 training operators/engineers in virtual plants, 48
- Major equipment summary, in product design
 Claus unit design converting H₂S, 1367–1368
 CO₂ and H₂S removal from coal-derived syngas, 1361–1362
 dimethyl ether (DME) production, 1281–1282
 downward-flow, oxygen blown, entrained-flow gasifiers, 1375
 drying oil (DO) production, 1304–1305
 ethylbenzene (EB) production, 1289–1291
 ethylene oxide production, 1315–1316
 formalin production, 1321–1323
 heptenes production, 1347–1350
 maleic anhydride production from benzene, 1309–1310
 styrene production, 1297–1298
 water-gas shift reactor design for conversion to CO₂, 1355
- Maleic anhydride production from benzene
 case study. *See* Report-writing case study
 major equipment summary, 1309–1310
 making it greener, 1171
 process description, 1305–1306
 process flow diagram, 1307
 reaction kinetics, 1306
 simulation (CHEMCAD) hints, 1311
 stream table, 1308
 utility summary table, 1309
- Manipulated variables (MVs)
 defined, 617
 in process control, 640
 setting up dynamic simulation, 626
 in split-range control system, 671–673
- Manometers, measuring flowrate, 731–734
- Manufacturing
 in chemical product design, 124–125, 130–131
 statistical process control in, 682
- Manufacturing cost estimates
 estimating utility costs from PFDs, 238–240
 expressed in units of dollars per unit time, 213
 factors affecting COM for chemical product, 213–218
 operating labor costs, 218–219
- overview of, 213
 sensitivity analysis for quantifying risk, 316–318
 in single-variable optimization, 480
 taxation, cash flow, profit and, 275
 treating liquid/solid waste streams, 240–241
 utility costs for cooling water tower, 221, 223–225
 utility costs for off-site plants with multiple units, 222–223
 utility costs for refrigeration, 225–228
 utility costs for steam production, 228–234
 yearly costs and stream factors, 237–238
- Margins. *See* Profit margins
- Margules equation, in solids modeling, 441–442
- Marketing department, data for PFD synthesis, 370
- Markets
 batch optimization and, 491
 supply and demand in chemical, 311–314
- Marshall and Swift Equipment Cost Index, inflationary trends, 179–181
- Mass balance
 fluid flow in piping systems, 698–699
 reactors and, 970–971
 relationships in separations, 876–877
- Mass-exchange networks (MENs)
 analyzing PFD for pollution/environmental performance, 1166–1167
 applying pinch technology to, 541–549
 heat-exchanger networks (HENs) vs., 541–542
 pinch or pinch point in, 509–510
- Mass separating agents
 defined, 876
 in mass balances, 877
 McCabe-Thiele method for, 903–905
- Mass, sizing pressure vessels, 1023–1024
- Mass transfer relationships
 continuous differential model for, 878–879
 obtaining height of packed column, 929
 reactors and, 965–969
 transfer units in, 880–881
 two-film model for, 879–880
- Matching volume/heat transfer area
 calculating in nonisothermal PFRs, 997–999
 in nonisothermal plug flow reactors, 999–1004
- Material balance
 McCabe-Thiele method for distillation, 890–892
 and two-film model in distillation column, 902
- Material balance, energy balance, rate equations, hydraulic equations, and equilibrium (MERSHQ) equations, 436–440
- Material balance, phase equilibrium, summation equations, and enthalpy balance (MESH) equations, 435–440
- Material balance, phase equilibrium, summation equations, and enthalpy balance (MESH) equations, 435–440
- Material factors
 Dow Fire & Explosion Index, 1152
 estimating plant cost for MOCs, 197
 for heat exchangers, process vessels and pumps, 1267–1271
 for other equipment, 1272–1274

- Material safety data sheets (MSDS), HazCom, 1136
- Materials of construction (MOCs)
 advantages/disadvantages of, 357
 bare module and material factors for, 1267–1271
 bare module equipment costs, 188–192
 bare module factor and costs, 199–201
 corrosion allowance for pressure vessels, 1022
 corrosion characteristics of some, 1019–1020
 in estimating capital costs, 194–199
 estimating grassroots vs. total module costs, 201–203
 estimating heat-exchanger network costs, 536–539
 estimating purchased equipment costs, 175
 for L-L separation, 1046–1047
 in life cycle analysis, 1168
 module costing technique, 185
 sizing pressure vessels, 1023–1024
- Maximum likelihood criterion, thermodynamic models, 602
- MBTI (Myers-Briggs Type Indicator), choosing group members, 1182
- McCabe-Thiele method
 for binary azeotropic distillation, 379–381
 determining column diameter, 916–920
 for distillation, 888–901
 for mass separating agents, 903–905
 overview of, 888
 for packed columns, 901–902
 vs. triangular diagrams for ternary azeotropic distillation, 382–383
- McMaster five-step strategy, 1106–1107
- McMaster Problem Solving (MPS) program, 1191
- Measurement, of process variables, 662–663
- Mechanical energy balance
 analyzing base-case ratio of equipment, 738–739
 calculating frictional losses, 709–711
 fluid flow in piping systems, 700–703
 friction factors in compressible flow, 719–720
 friction factors in incompressible flow, 712–719
 performance analysis of pumps using NPSH, 741–743
- Mechanical flow diagram (MFD). *See* Piping and instrumentation diagrams (P&IDs)
- Melting point, impacting environment fate of chemicals, 1163
- Membrane separation
 in gas permeation, 947–950
 rate expressions for, 882–883
 recycling raw materials, 72
- Memory matrix (or categorizing grid), in outcomes assessment, 4
- Memos, for written communications, 1198
- MENS. *See* Mass-exchange networks (MENS)
- MESH (material balance, phase equilibrium, summation equations, and enthalpy balance) equations, 435–440
- Metals
 in pressure vessel construction, 1016–1018, 1023–1024
 thermal conductivities of heat exchanger, 800–801
- Methane
 determining profit margin, 68–69
 excess reactant in feed, 162–164
 input/output structure of PFD, 61–63
 limitations of tracing chemical pathways in PFDs, 145–146
 producing with toluene and hydrogen, 11
 tracing primary chemical pathways for, 141–142
- Method of lines, in dynamic simulation, 632
- MFD (mechanical flow diagram). *See* Piping and instrumentation diagrams (P&IDs)
- Microeconomic theory, changes in supply and demand, 311
- Mine Safety and Health Administration (MSHA), 1135
- Minimum fluidization velocity, in fluidized beds, 728–730
- Minimum Gibbs free energy equilibrium reactor, 408
- Minimum number of exchangers (MUMNE)
 constructing cascade diagram, 514–516
 constructing heat-exchanger network (HEN), 517–523
 handling streams with phase changes, 539–540
 HENSAD program addressing, 540–541
 for mass-exchange networks (MENS), 510, 542–544, 548
 minimum approach temperature, 513
 minimum number of heat exchangers, 516–517
 overview of, 512
 pollution prevention design and, 1165
 temperature interval diagram, 513–514
- Minimum temperature approach, using MUMNE for HENS, 513, 524, 527–529, 535–536
- MINLP (mixed-integer nonlinear programming), 464
- Minutes from design meetings, 1199
- Mission, in group formation, 1184
- Mist eliminators
 Droplet distribution/separation efficiency from, 1040–1044
 flooding in, 1038–1040
 in V-L separation, 1036–1037
- Mixed-integer nonlinear programming (MINLP), 464
- Mixer-settlers, extraction equipment, 943, 946
- Mixers
 bare module factors for, 1274
 conditions of special concern for, 155–158
 equipment cost data for, 1250–1251
 input for process simulation, 407
 purchase costs for, 1262
 tracing chemical pathways in PFDs, 135–136
- Mixing drums, as separation equipment, 912
- Mob effect, organizational behavior, 1183–1184
- Mobile truth, ethical decision-making and, 1107–1108, 1183–1184
- MOCs. *See* Materials of construction (MOCs)
- Model algorithmic control (MAC), 683
- Model-based controls, advanced process control, 683
- Model Predictive Control (MPC), 683
- Modeling techniques, in steady-state simulation, 562
- Models
 electrolyte systems. *See* Electrolyte systems modeling
 gas permeation membranes, 949–950
 reactor, 972–980
 of reactors, 1001–1002
- Modified accelerated cost recovery system. *See* MACRS (modified accelerated cost recovery system) depreciation allowances
- Modular approach
 sequencing batch operations, 60
 solution of DAE in dynamic simulation, 634
- Modular method, solutions to DAE systems, 634
- Module costing technique
 bare module equipment costs at base conditions, 186–189
 bare module equipment costs at nonbase conditions, 189–194
 calculating bare module costs, 199–201
 grassroots and total module costs, 201–203
 materials of construction (MOCs) and, 194–199
 overview of, 185
- Molal (constant molar) overflow, in binary distillation, 890, 893
- Molar volume, modeling electrolyte systems, 432, 448
- Money, investments and time value of, 248–251
- Monte-Carlo (M-C) method
 CAPCOST program applying, 325
 evaluating risks of new technology, 324–325
 factoring into economic analysis, 1168
 for quantifying risk, 321–324
- Moody diagram, friction factors, 709
- Moody plot, defined, 709
- Moral autonomy
 developing. *See* Ethics and professionalism
 in making ethical decisions, 1105
 whistle-blowers and, 1115
- Mother liquor, recycling raw materials in batch processing, 97
- Motivation, friction in groups from low, 1180–1181
- MPC (Model Predictive Control), 683
- MSDS (material safety data sheets), HazCom, 1136
- MSHA (Mine Safety and Health Administration), 1135
- Multiproduct batch processes
 design of equipment for, 111–112
 flowshop plants for, 101–103
 intermediate storage, 108–110
 jobshop plants, 103–106
 parallel process units, 110–111
- Multistage steam ejectors, 1054–1057

- Multistep methods, numerical integrator methods, 636
- MUMNE. *See* Minimum number of exchangers (MUMNE)
- Murphree efficiencies, calculating tray efficiency, 920
- MVs. *See* Manipulated variables (MVs)
- Myers-Briggs Type Indicator (MBTI), choosing group members, 1182
- N**
- NAAQS (National Ambient Air Quality Standards), 1140
- NAFTA (North American Free Trade Agreement) Ethics, 1119
- Naphthalene, producing phthalic anhydride from, 1402–1404
- NASA (National Aeronautics and Space Administration) library website, 1191
- National Aeronautics and Space Administration (NASA) library website, 1191
- National Ambient Air Quality Standards (NAAQS), 1140
- National Council of Examiners for Engineering and Surveying (NCEES), 1122–1124
- National Institute for Engineering Ethics (NIEE), 1118–1119
- National Institute for Occupational Safety and Health (NIOSH)
air contaminants standard, 1135–1136
health/safety information for employees/employers, 1135
- National Response Center, EPA, 1141
- National Society of Professional Engineers (NSPE)
code of ethics, 1113–1114
overview of, 1119, 1121
on whistle-blowing, 1115–1117
- Nationally Recognized Testing Laboratory (NRTL)
calculating Gibbs free energy for electrolyte systems, 430
liquid-state activity-coefficient models, 419–422
- Natural gas
cost of, 219–220
as fuel of choice for this text, 220–221
utility costs for, 234
- Natural resources, green engineering and, 1159
- NCEES (National Council of Examiners for Engineering and Surveying), 1122–1124
- Needs analysis, in chemical product design, 124–127
- Net positive suction head (NPSH)
heuristics for pumps, 360
pump performance and, 739–743
pump-system curves and, 744
reasons for elevating equipment, 41
safe pump performance and, 739–743
tray spacing, flooding and, 915
troubleshooting cumene process feed section, 1075
troubleshooting cumene production facility, 1423–1424
- Net present value (NPV)
comparing large projects, 296–298
discounted profitability criteria for, 291–295
modeling objective functions for, 470, 488–489
new facility design for allyl chloride production, 1395
optimizing flowsheet using before-tax, 597–600
in parametric optimization, 480–484, 487
profitability of equipment for, 299–300, 304
quantifying risk, 314–318
quantifying risk for, 321–324
- Net present worth (NPW), 291–293
- New Source Performance Standards (NSPS), 1140
- Newton's method
equation-oriented (EO) approach and, 585–586
modeling distillation column for electrolyte system, 450
performance for tear stream convergence, 583
steady-state simulation algorithms, 579–585
- NGOs (nongovernmental organizations), 1134
- Nickel and its alloys, materials of construction (MOCs), 194–197
- NIEE (National Institute for Engineering Ethics), 1118–1119
- NIOSH (National Institute for Occupational Safety and Health)
air contaminants standard, 1135–1136
health/safety information for employees/employers, 1135
- NIOSH *Pocket Guide to Chemical Hazards*, 1135
- Nitrogen, alternative schemes for compression of, 156
- Nominal annual interest rate, 254
- Non-stoichiometric feed conditions
justifying conditions of special concern in PCM, 161–163
reasons for operating at conditions of special concern, 154
- Nondiscounted methods, incremental analysis, 305–308
- Nondiscounted profitability criteria, 287–291
- Nonequilibrium-stage modeling, MERSHQ in, 436–440
- Nonfeasible distillation processes, ternary azeotropic distillation, 386
- Nonferrous alloys, estimating plant cost, 194–197
- Nongovernmental organizations (NGOs), 1134
- Nonisothermal conditions, equipment design
fluidized bed reactors. *See* Fluidized bed reactors
nonisothermal CSTRs, 980–984
- Nonisothermal continuous stirred tank reactors (CSTRs)
overview of, 980–984
performance problems, 1004–1006
- Nonisothermal plug flow reactors (PFRs)
cooling medium, 991
examples, 993–997
- hierarchies for exothermic/endothermic reactions, 984–986
matching volume and heat transfer area, 997–999
overall heat transfer coefficient, 992–993
performance problems, 1004–1006
pressure of process gas, 992
reactor concentration and temperature profiles, 987–989
role of heat transfer in reactor design, 990–991
- Nonlinear equation solvers, in dynamic simulation, 637–639
- Nonlinear-programming (NLP)
in optimization, 464
in steady-state simulation, 590
- Nonlinear Q versus T Curves, in heat exchanger relationships, 776–777
- Nonoverlapping operations, in batch processing, 98–99
- Nonprofessional responsibilities, ethical problem-solving, 1108–1110
- Nonreacting chemicals, tracing, 145
- Norming stage, in group evolution, 1185–1186
- North American Free Trade Agreement (NAFTA) Ethics, 1119
- Notation
S-T heat exchanger, 781
in tables, 1217
- Notes, oral presentation guidelines, 1214
- Nozzles
calculating discharge velocity, 702–703
measuring flowrate with, 731, 735
for pressure vessel design, 1023
for single-stage steam ejectors, 1051–1052
sizing pressure vessels and, 1023–1024
- NPSH. *See* Net positive suction head (NPSH)
- NPV. *See* Net present value (NPV)
- NPW (net present worth), 291–293
- NRTL (Non Random Two Liquid)
calculating Gibbs free energy for electrolyte systems, 430
liquid-state activity-coefficient models, 419–422
- NSPE. *See* National Society of Professional Engineers (NSPE)
- NSPS (New Source Performance Standards), EPA, 1140
- Nucleate boiling, 813
- Numbers
for figures and tables in reports, 1206
guidelines for equations in reports, 1207–1208
identifying process equipment in PFDs, 16–17
- Nusselt number
analysis of falling-film condensation, 824–825
falling-film condensation on cylinders, 825–828
heat transfer coefficients for laminar flow in tubes, 807–809
heat transfer coefficients for turbulent flow in tubes, 804–806

O

- Objective function
 - base cost analysis in optimization, 471
 - calculating base case using, 469–470
 - defined, 464
 - in easy vs. difficult optimization problems, 468
 - effect of topological change on parametric optimization, 475–476
 - identifying and prioritizing key decision variables, 471–472
 - optimization and, 470–471
 - optimizing flowsheet, 590–592
 - optimizing flowsheet using, 597–600
 - sensitivity to changes in decision variables, 487–489
 - in single-variable optimization, 480
 - OBL (outside battery limits), estimating plant costs, 206–208
 - Obligations, in ethical problem-solving, 1110
 - Occupational Safety and Health Administration (OSHA)
 - air contaminants standard, 1135–1136
 - HAZWOPER rule, 1135–1136
 - health and safety risk assessment, 1135
 - incidence rate statistics, 1132–1133
 - legal liability of chemical engineers, 1126
 - process safety management (PSM), 1138–1140, 1142
 - Octanol-water partition coefficient, 1162
 - ODEs (Ordinary differential equations), in dynamic simulation, 632, 634
 - Off-site recycle, Pollution Prevention Act of 1990, 1160
 - On-site recycle, Pollution Prevention Act of 1990, 1160
 - One-shot rising (OSR) internal device, Ladder Diagram (LD), 681
 - Open-cup method, measuring flash point of liquid, 1144
 - Open-loop (OL) response, dynamic simulation and, 639–640, 642–643
 - Operating conditions
 - changes during parametric optimization, 484
 - decision variables in parametric optimization, 479
 - Operating costs
 - data for optimization base case, 470
 - discounted methods for incremental analysis, 309
 - evaluating equipment using EAOC method, 302–305
 - evaluating equipment with different expected operating lives, 300–302
 - evaluating equipment with same expected operating lives, 299–300
 - evaluating profitability of new project, 286
 - Operating labor costs
 - in formula for COM, 214–217
 - in manufacturing cost estimation, 218–219
 - Operator training simulator (OTS)
 - building, 43–45
 - linking with ITS systems, 46–48
 - regulating and controlling chemical processes, 683–688
 - training control room operators, 688–689
 - Operators
 - estimating labor cost of manufacturing, 218–219
 - operator training simulators (OTS), 43–48
 - P&IDs used for training, 31
 - Optimal control, in advanced process control, 683
 - Optimization
 - background information on, 463–464
 - base case approach to, 469–470
 - base cost analysis, 471
 - batch systems and, 490–494
 - batch systems and optimum cycle time, 495–497
 - communicating results of, 468–469
 - early identification of alternatives in, 477–480
 - equation-oriented (EO) approach using, 586
 - estimating problem difficulty, 467–468
 - flexibility and sensitivity of the optimum, 489–490
 - flowsheet optimization using decision variables, 484–489
 - identifying and prioritizing decision variables, 471–472
 - lattice search, response surface, and mathematical optimization techniques, 489
 - misconceptions in, 465–467
 - modeling objective function in terms of decision variables, 488–489
 - objective functions in, 470–471
 - parametric. *See* Parametric optimization
 - problem-solving 20,000-metric-tons-per-year facility for allyl chloride production, 1395
 - scheduling equipment for batch processes, 490–494
 - selecting objective function for, 464
 - sensitivity of objective function to changes in decision variables, 487
 - single-variable example, 480–481
 - steady-state simulation and, 589–592
 - steady-state simulation examples, 593–600
 - strategies for, 469–472
 - terminology used in, 464
 - top-down and bottom-up strategies, 468
 - topological optimization, 473–479
 - two-variable example, 481–484
 - Oral communication
 - audience analysis and, 1196
 - briefings, 1211
 - formal presentations, 1210–1211
 - software and author responsibility, 1215–1218
 - techniques for, 1209–1210
 - visual aids, 1211–1212
 - WVU and Auburn University guidelines, 1212–1214
 - Order-of-Magnitude, capital cost estimates, 172–174
 - Ordinary differential equations (ODEs), in dynamic simulation, 632, 634
 - Organizational behaviors, in groups, 1176, 1180–1184
 - Organizational structure, of group, 1182
 - Orifice, flowrate measurement, 731–735
 - OSHA. *See* Occupational Safety and Health Administration (OSHA)
 - OSR (One-shot rising) internal device, Ladder Diagram (LD), 681
 - OTS. *See* Operator training simulator (OTS)
 - Outcomes assessment
 - by faculty, 4–6
 - overview of, 1–2
 - results of, 1
 - student self-assessment, 2–4
 - summary, 6
 - Outline, oral presentation guidelines, 1212
 - Output devices (or coils), Ladder Diagram (LD), 680
 - Output display options, selecting for simulation, 411
 - Output variables (or outputs)
 - in dynamic simulation, 617
 - equipment geometry/size for dynamic simulation, 622–624
 - Outside battery limits (OBL), estimating plant costs, 206–208
 - Overall conversion
 - efficiency of use of raw materials, 70–71
 - of reactant, 965
 - Overall heat transfer coefficient (U)
 - equipment parameters in process simulation, 405
 - exchanging heat between streams and utilities, 678
 - in feed-forward control example, 667
 - in fluidized-bed reactor design, 1388
 - in heat transfer, 679
 - process control exercise using, 645–646
 - in reaction kinetics, 1306
 - reactor performance problems, 1005
 - for reactors, 992–997
 - resistances, 798–800
 - using dynamic simulators in design, 638
 - variance within heat-exchanger, 777–778
 - Overlapping operations, in batch processing, 100–103
 - Overreliance on team members, 1189
- P**
- P-only (proportional-only) controllers, dynamic simulation, 640
 - Packed-bed absorber, troubleshooting, 1071–1074
 - Packed bed-absorber, troubleshooting case study, 1071–1074
 - Packed columns, McCabe-Thiele distillation method for, 901–902
 - Packed towers
 - choosing tray towers vs., 933
 - obtaining height and diameter of, 929–931
 - packing types and shapes, 928
 - performance problems, 933–934
 - pressure drop in, 931–933
 - vapor-liquid separation using, 926–927

- Packing
 bare module cost for, 1270
 bare module factors for, 1271
 equipment cost data for, 1251
 material factors for, 1273
 pressure factors for, 1266
 purchase costs for, 1257
- Paper-and-pencil studies, capital cost estimates as, 174
- PAR analysis, creating new heuristics, 349–351
- Parallel plate settlers, L-L separation, 1046–1047
- Parallel process units, increasing production, 110–111
- Parallel reactions, reaction kinetics and, 977–980
- Parameters
 modeling distillation column for electrolyte system, 447–448
 modeling solids, 442–444
 Monte-Carlo analysis for quantifying risk, 321–324
- Parametric optimization
 flowsheet optimization using decision variables, 484–487
 overview of, 479
 single-variable example of, 480–481
 two-variable example of, 481–484
- Pareto analysis, of base costs in optimization, 471
- Partial differential equations (PDEs), 632
- Partitions
 adjusting in heat exchanger for each phase, 679
 in S-T heat exchangers, 784–785
 in sequential modular approach, 572–578
- Passive voice, for written design reports, 1202
- Pattern search, parametric optimization, 489
- Pavlov equation, frictional losses, 710
- Payback period (PBP)
 discounted payback period (DPBP), 291–293
 incremental payback period (IPBP), 305–308
 time-related criteria in project evaluation, 287–291
- PCM (Process conditions matrix), conditions of special concern, 158–164
- PDEs (partial differential equations), 632
- PDMS software, from CadCentre, 41
- PE (Principles and Practice) exam, 1124–1125
- PEL (Permissible exposure limits), OSHA air contaminants standard, 1135
- Peng-Robinson (PR) fugacity model, 417–418
- Performance
 fluid flow. *See* Fluid flow equipment, performance
 fluid mechanics. *See* Fluid mechanics
 heat exchangers. *See* Heat exchangers, performance
 heat transfer and. *See* Heat transfer
 knockout drums. *See* Knockout drums (phase separators)
 of Model Predictive Control (MPC) applications, 683
 packed and tray towers, 933–934
 PID controller, 640–641
 pinch technology and, 510
 pressure vessels. *See* Pressure vessels
 process variables regulating, 662–663
 reactor, 1003–1006
 steam ejectors
 updating PFD to reflect changes in, 26
- Permissible exposure limits (PEL), OSHA air contaminants standard, 1135
- Personal income, ways to distribute, 248–251
- PERT (program evaluation and review technique), group scheduling, 1185
- Pervaporation, for purification of ethanol, 380–381
- Pesticides, environmental law for, 1161
- PHA (Process Hazard Analysis), 1145–1146
- Phase changes
 heat exchangers with stream, 775–776
 LMTD correction and, 797–798
- Phase equilibrium
 binary interaction parameters (BIPs) in, 417–418
 choosing model for, 416–417
 dynamic simulation setup, 621
 equations of state in, 417–418
 flash units and, 408
 liquid-state activity-coefficient models and, 419–423
 MESH used in, 435–440
 physical property data for PFD design, 371
 unit operation calculations, 563
 using thermodynamic models, 425
- Phase separators. *See* Knockout drums (phase separators)
- Phenol, production of, 1417
- Phenomenological reactor models, 1001
- Phthalic anhydride production, at new facility, 1412–1416
- Phthalic anhydride production, scaling down assignment, 1411
 background, 1401
 equipment summary table, 1409–1410
 flow summary table, 1406–1407
 other information, 1403
 phthalic anhydride, 1402
 process flow diagram, 1402–2003
 pump and compressor curves, 1405
 pump curves, 1404
 report format, 1411
 utility summary table for current operation, 1408
- Physical properties
 base-case ratios applied to, 737
 choosing thermodynamic models, 416
 data for PFD synthesis, 371
 estimating fate of chemicals in environment, 1160–1163
 heuristics for, 355
 measuring process variables, 662
 models for process simulation, 401–404
 parameter estimates for thermodynamic models, 601–604
 solids modeling and, 440–442
- PI (proportional-integral), controllers, dynamic simulation, 640
- Pictures, in design reports, 1200, 1206–1207
- PID (proportional-integral-derivative), controllers, dynamic simulation, 640–643, 645
- Pie charts
 common mistakes made in, 1225
 corrected version of, 1226
 in design reports, 1200
 guidelines for, 1206–1207
- Pilot plants, developing processes in, 60
- Pinch, defined, 509
- Pinch technology
 below the pinch, 516–517, 542
 composite enthalpy curves and, 524–529
 composite temperature-enthalpy diagram, 523–525
 design at the pinch, 518, 520
 design away from the pinch, 519, 520–523
 design below the pinch, 519–520
 determining EAOC for network, 534–535
 effectiveness factor (F) and number of shells, 529–534
 heat-exchanger network synthesis analysis and design (HENSAD), 540–541
 heat integration and network design, 510–513
 mass-exchange networks, 541–549
 materials of construction and operating pressure issues d, 536–539
 MENS, 541–549
 multiple utilities and, 539
 overview of, 509–510
 solving MUMNE problem, 512–521
 streams with phase changes and, 539–540
- Pinch zone (or pinch temperature)
 design of heat-exchanger network above, 518
 design of heat-exchanger network below, 519
 overview of, 514–515
- Pipe racks, 34–37
- Pipeless batch processes, 60
- Pipes
 calculating frictional losses, 709–711
 calculating pipe sizes in 3-D plot plan, 37–38
 constructing P&IDs, 27–29
 cumene production facility problems, 1427
 drawing isometrics for every pipe in plant, 33
 as fluid flow equipment, 703–708
 friction factors in incompressible flow, 712–719
 heuristics for, 360
 major process and utility, in 3-D plot plan, 41
 sketching in 3-D plot plan, 41
 in system design. *See* Fluid mechanics
- Piping and instrumentation diagrams (P&IDs)
 acrylic acid separations process, 1050
 applications of, 31–32
 in case history, 10
 constructing, 27–30
 data excluded from, 27
 in design reports, 1200
 plant construction information in, 27
 as starting point for OTS system, 44–45
 summarizing equipment in, 21–23
- Plagiarism, citations of other work vs., 1200
- Planar geometry, overall heat transfer coefficient and, 799

- Planned emissions, EPA, 1140–1141
- Plant costs
- bare module equipment costs at base conditions, 186–189
 - bare module equipment costs at non-base conditions, 189–194
 - calculating bare module costs, 185
 - calculating grassroots vs. total module costs, 201–203
 - CAPCOST for calculating bare module costs, 204–206
 - CEPCI and Marshall and Swift indices, 179–181
 - CEPCI applied for inflation, 183–184
 - estimating based on capacity, 206–208
 - estimating total, 182–184
 - factors affecting, 182–183
 - Lang Factor technique for, 184
 - materials of construction (MOCs) and, 194–199
 - module costing technique for, 185
- Plants
- dynamic modeling for start-up/shutdown, 619
 - flowshop, 101–103
 - jobshop, 103–106
- Plastics, advantages/disadvantages of, 356
- Plate-and-frame heat exchangers, LMTD correction factor, 797
- Plate baffles, S-T heat exchanger design, 785–786
- PLCs (programmable logic controllers), 680–682
- Plot plans
- 3-D representation of. *See* 3-D representation of process (plant model)
 - locating all equipment in plant, 32–33
- Plug flow reactors (PFRs). *See also* Nonisothermal plug flow reactors (PFRs)
- dynamic simulation of, 632
 - examples, 974–975
 - input for process simulation, 408
 - overview of, 973–974
 - performance problems, 1003–1006
 - replacing with series of CSTRs, 632
- Pneumatic conveying (transport) reactors, 1001
- Poisons, when to purify the feed, 66
- Pollution
- analyzing PFD for, 1166–1167
 - design processes to minimize. *See* Green engineering
 - economics of preventing, 1167–1168
 - preventing in process design, 1164–1166
- Pollution Prevention Act (PPA), 1159–1161
- Polyethylene, life cycle analysis of, 1168–1169
- Polymers
- estimating plant cost for MOCs, 194
 - used for smaller pressure vessels, 1016
- Polymorphs, solids modeling and, 440–441
- Pool boiling
- determining critical or maximum heat flux in, 815–816
 - effects of forced convection on, 817–822
 - heat transfer coefficients, 813–817
- Pop valves, in pressure-relief systems, 1145
- Portable devices, in chemical product design, 127, 128
- Positive displacement compressors, 709, 750
- Positive displacement pumps
- increasing pressure/regulating flowrate in streams, 674–676
 - overview of, 706
 - performance analysis of fluid flow in, 745–746
- Postmortem analysis, oral presentation guidelines, 1214
- Postrationalization, in justification behavior, 1108
- Potential energy, in piping systems, 700–703
- Power recovery equipment
- bare module cost for, 1270
 - bare module factors for, 1271
 - heuristics for, 358
 - input for turbines in process simulation, 406
 - purchased costs for, 1273
- PPA (Pollution Prevention Act), 1159–1161
- PR (Peng-Robinson) fugacity model, 417–418
- Practicing, oral communications, 1209
- Precedence ordering, in sequential modular approach, 572–574, 577
- Precipitators, in batch optimization, 490–494
- Predict, PAR analysis for new heuristics, 349–351
- Predictive problems, performance, 696
- Predictor-Corrector methods, numerical integrator methods, 636–637
- Preliminary design of chemical processes
- acetone. *See* Acetone production from isopropyl alcohol
 - acrylic acid. *See* Acrylic acid production from propylene
 - CO₂ and H₂S removal. *See* CO₂ and H₂S removal from coal-derived syngas converting H₂S. *See* Claus unit design, converting H₂S to elemental sulfur
 - dimethyl ether (DME), 1278–1283
 - downward-flow, oxygen blown, entrained-flow gasifiers, 1371–1377
 - drying oil. *See* Drying oil (DO) production
 - ethylbenzene. *See* Ethylbenzene (EB) production
 - ethylene oxide. *See* Ethylene oxide production
 - formalin. *See* Formalin production
 - heptenes. *See* Heptenes production
 - L-phenylalanine and L-aspartic acid. *See* L-phenylalanine and L-aspartic acid, batch production
 - maleic anhydride. *See* Maleic anhydride production from benzene
 - material factors in equipment cost, 1272–1274
 - scope estimate, 172–173
 - styrene. *See* Styrene production
 - WGS reactor converting CO to CO₂, 1352–1356
- Preliminary Design (Scope), in cost estimate, 172
- Present value ratio (PVR), in project evaluation, 291–293
- Presentation mechanics, guidelines for oral, 1213–1214
- Pressure
- bare module costs at non-base conditions, 189–194
 - bare module factor and costs, 199
 - condenser and reboiler affecting, 925
 - control system for binary distillation column, 685–687
 - devices increasing gas, 707
 - estimating HEN costs, 536–539
 - estimating plant cost for MOCs, 197–199
 - estimating utility costs for cooling water tower, 224
 - evaluating reactor process conditions, 158–164
 - fluidized beds and, 728
 - friction factors in incompressible flow, 713–714
 - heat exchange between streams and utilities, 676–678
 - heat transfer coefficients for pool boiling curve, 813–815
 - increasing and regulating, 674–676
 - measuring process variables, 662
 - operating conditions of special concern for reactors/separators, 150–152, 154
 - physical property variations and, 355
 - reactor design for PFD synthesis and, 372
 - reducing with valves, 705
 - regulating flowrates and, 660–662
 - in two-variable optimization, 481–484
 - utility costs for refrigeration and, 227–228
 - utility costs for steam production and, 228–234
- Pressure drop
- calculating for packed tower, 931–933
 - calculating in nonisothermal PFRs, 992
 - for condensers and reboilers, 924–925
 - debottlenecking allyl chloride reactor, 1087–1088
 - estimating column, 935–936
 - heat exchanger design considerations, 837–841
 - increasing allyl chloride production, 1386
 - matching volume with heat transfer in S-T reactors, 997–999
 - measuring flowrate by creating, 730–735
 - S-T heat exchanger design, 844–846
 - in tray towers, 922–923
 - troubleshooting acrylic acid product, 1076–1078
 - troubleshooting steam release in, 1080–1081
- Pressure-flow networks, 619–622
- Pressure-relief systems, 1145
- Pressure-relief valves, 1095–1096, 1145
- Pressure-swing adsorption
- guidelines for choosing separation units, 374
 - recycling raw materials, 72, 77
 - when applicable, 382
- Pressure vessels
- corrosion allowance, 1022
 - cylindrical shells, 1016–1021
 - designing, 1016
 - heads, 1022
 - heuristics for, 359
 - mass of vessels and heads, 1023–1024
 - material properties, 1016
 - nozzles, 1023
 - purpose of, 1015

- Pressure wave, in explosions, 1144
- Price, supply/demand affecting market, 311–314
- Primary chemicals, 136–142
- Primary flow paths
- justifying conditions of special concern for, 136
 - for toluene hydroalkylation process, 137–140
- Principal, or present value, of investment, 249
- Principles and Practice (PE) exam, 1124–1125
- Probabilistic approach to quantifying risk
- Monte-Carlo method, 318, 321–324
 - overview of, 318–321
 - using new technology, 324–325
- Probability distributions
- Monte-Carlo analysis for quantifying risk, 321–324
 - Monte-Carlo method, 321–324
 - quantifying risk and, 318–321
- Problem-Based Learning* (Woods), 1190–1191
- Problem-solving
- debottlenecking. *See* Debottlenecking
 - estimating problem difficulty, 467–468
 - strategies for, 1067–1069
 - in troubleshooting. *See* Troubleshooting
- Process concept diagrams, 60–61
- Process conditions
- analysis of, 158–159
 - evaluation of exchangers, 164
 - evaluation of reactors, 159–164
 - for operating at conditions of special concern, 150–154
 - overview of, 149–150
 - of special concern for operation for other equipment, 155–158
 - of special concern for separation/reactor systems, 150–152
- Process conditions matrix (PCM), conditions of special concern in, 158–164
- Process design. *See* Experience-based principles, in process design
- Process flow diagrams (PFDs). *See also* Synthesis of PFD, from BFD
- for 3-D representation of process, 34–35
 - batch processes vs. continuous process, 56–60
 - in case histories, 10
 - combining topology, stream data, and control strategy, 21–26
 - conditions of special concern and. *See* Process conditions
 - in design reports, 1200
 - equipment information in, 21
 - estimating utility costs from, 238–240
 - formulating preliminary, 78–83
 - heat-exchanger network/process energy recovery, 83
 - hierarchy of process design, 55–56
 - information in, 14, 83–84
 - input/output structure for, 61–63
 - pollution/environmental performance, 1166–1167
 - process simulation flowsheets vs., 1217–1218
 - process topology in, 14–18
 - recycle structure. *See* Recycle structure
 - regulation problem using, 655
 - separation sequence structure in, 83
 - stream information, 18–20
 - tracing chemicals. *See* Tracing chemical pathways, in PFDs
 - understanding, as central goal of this book, 11
 - updating changes on, 26
- Process fluid mechanics. *See* Fluid mechanics
- Process Hazard Analysis (PHA), 1145–1146, 1149
- Process heat exchangers, dynamic models for, 627–630
- Process optimization. *See* Optimization
- Process Safety Management (PSM) of Highly Hazardous Chemicals, OSHA
- overview of, 1138–1140
 - Risk Management Plan (RMP), EPA, 1142
- Process streams. *See* Streams
- Process topology
- categorizing information in PFDs, 14–18
 - changes from steady-state simulation, 619–622
 - combining to give PFD, 21–23
 - input flowsheet data for process simulation, 404
 - reaction kinetics data for PFD, 370–371
 - remaining fixed in parametric optimization, 483
- Process vessels. *See* Vessels
- Producer, investment, 249
- Product chemicals
- tracing primary chemicals, 136
 - troubleshooting off-specification product, 1076–1078
 - unwanted products impacting equilibrium or reactor operation, 77
- Product design. *See* Chemical product design
- Product manufacture, in life cycle analysis, 1169
- Product quality, continuous vs. batch processes and, 57
- Product specification, choosing separation units for PFD synthesis, 375
- Product storage
- intermediate storage, 108–110
 - for single-product campaigns, 106–108
- Product use and reuse, in life cycle analysis, 1169
- Professional development hours (PDHs), renewing PE license, 1125
- Professional life, whistle-blowing consequences, 1115
- Professional registration (certification) engineer-in-training certification, 1122–1124
- Principles and Practice (PE) exam, 1124–1125
- reasons for, 1121–1122
- Professionalism. *See* Ethics and professionalism
- Profit, impact of tax rate on, 274–277
- Profit margins
- base costs in optimization, 471
 - economics of chemical product design, 130–131
 - evaluating, 325–326
 - information from input/output diagrams, 68–69
 - recycling raw materials and, 97
- Profitability analysis
- cash flow diagram for new project, 285–287
 - discounted criteria and, 291–295
 - equipment with different expected operating lives in, 300–305
 - equipment with same expected operating lives in, 299–300
 - evaluating risks of new technology, 309–310
 - forecasting uncertainty in chemical processes, 310–314
 - incremental analysis comparing large projects, 295–297
 - incremental analysis for retrofitting facilities, 305–309
 - Monte-Carlo analysis for quantifying risk, 321–324
 - nondiscounted criteria, 287–291
 - probabilistic approach to quantifying risk, 318–321
 - profit margins in, 325–326
 - rate of return on investments, 298–299
 - risk when using new technology, 324–325
 - scenario analysis for quantifying risk, 314–315
 - sensitivity analysis for quantifying risk, 315–318
- Programmable logic controllers (PLCs), 680–682
- Progress reports, written communications as, 1199
- Propellers, vs impellers of centrifugal pumps, 706–707
- Proportional-integral-derivative (PID), controllers, dynamic simulation, 640–643, 645
- Proportional-integral (PI), controllers, dynamic simulation, 640
- Proportional-only (P-only) controllers, dynamic simulation, 640
- Proprietary knowledge, business codes of conduct, 1127
- Propylene. *See also* Heptenes production
- design new facility for allyl chloride production, 1394–1396
 - producing acrylic acid from. *See* Acrylic acid production from propylene
 - producing allyl chloride from, 1383–1386
 - producing cumene from. *See* Cumene production facility problems
 - producing heptenes from. *See* Heptenes production
- PSM (Process Safety Management) of Highly Hazardous Chemicals, OSHA
- overview of, 1138–1140
 - Risk Management Plan (RMP), EPA, 1142
- Public speaking. *See* Oral communication
- Pulsed columns, extraction equipment, 943
- Pump pits, dangers of, 39–40
- Pumps
- bare module and material factors for, 1267–1271
 - calculating horsepower requirements, 713–715
 - capacities of process units in common usage, 356
 - equipment cost data for, 1251

- Pumps (*continued*)
 estimating utility costs from PFDs, 238–240
 as fluid flow equipment, 706–707
 friction factors in incompressible flow, 712–719
 heuristics for, 360, 361
 increasing pressure/regulating flowrate in process streams, 674–676
 input for process simulation, 406
 mechanical energy balance in piping systems, 700–703
 performance analysis of pump curves, 743–749
 performance analysis using NPSH, 739–743
 performance of feed section to process, 751–755
 pressure factors, 1266
 purchase costs, 1254
 types of, 706–707
- Punctuation, in written design reports, 1202–1203
- Purge stream, recycling feed and product, 73–75
- Purity
 decision variables in parametric optimization, 479
 of feed, 66–67
 of raw material streams prior to recycling, 76
 recycling raw materials, 71
- PVR (present value ratio), in project evaluation, 291–293
- Q**
- Quadratic Programming (QP)
 defined, 464
 flowsheet optimization using Successive QP (SCP), 590–591
 solving linear MPC problems, 683
- Quantitative assessment, in chemical product design, 129
- Quasi-Newton method
 applying to thermodynamic properties, 563–564
 Broyden's method as, 579–580
 equation-oriented (EO) approach and, 585–586
- Question-and-answer period, oral communications, 1210, 1214
- R**
- Radial geometry, overall heat transfer coefficient, 799
- Raffinate, defined, 910
- Random numbers, M-C analysis for quantifying risk, 321–322
- Random packings, packed towers, 928, 930
- Rate equations
 for flowrate of stream, 660
 for fluid flow, heat transfer, mass transfer and chemical reactors, 436–440
 kinetic reactors and, 408
 in nonequilibrium-stage modeling problem, 436
 required in EPA hazard assessment, 1142
- Rate expressions, relationships in separations, 882–883
- Rate of return on investment (ROROI)
 establishing acceptable, 298–299
 nondiscounted methods for incremental analysis, 305–308
 nondiscounted profitability criteria and, 289–291
 objective functions in optimization, 470
- Ratio control system
 applied to water-gas shift (WGS) reactor, 669–671
 overview of, 669
- Raw materials
 affecting supply and demand curves, 313
 calculating yearly cost of, 237–238
 designing pollution prevention, 1165
 determining profit margin, 68–69
 efficiency of use, 70–71, 541–549
 estimating manufacturing costs, 234–237
 green chemistry and, 1163–1164
 in life cycle analysis, 1168
 profit margin analysis using cost of, 326
 purifying prior to recycling, 76
 recycle section of PFD synthesis and, 389
 recycling to ensure maximum profit, 97
 recycling unreacted, 71–75
- RCRA (Resource Conservation and Recovery Act), 1141, 1161
- REACH (Registration, Evaluation, Authorization and Restriction of Chemicals), 1137
- Reactants
 evaluating excess in feed, 154
 excess affecting recycle structure, 76
 justifying conditions of special concern for reactors, 162–163
 potential number of recycle streams and, 75–76
 in process concept diagrams, 60–61
 tracing, 136
- Reaction kinetics
 choosing thermodynamic models, 415
 justifying conditions of special concern in reactors using PCM, 159–160
 resources on, 84
 role in correct design for chemical reactors, 966–968
 in synthesis of PFD from BFD, 370–371
- Reaction rates
 impact of pressure on, 163
 impact of temperature on, 162–163, 980
 justifying reactors operating at temperature conditions of special concern, 152–153
 in reactor and separator feed preparation, 388–389
 reactor kinetics and, 962–964
 synthesis of PFD from generic BFD, 371
 using continuous vs. batch processes, 59
- Reaction vessels. *See also* Vessels
 in batch processing, 92–94
 batch processing equipment design, 111
 quantifying risk, 314–315
- runaway reactions and catastrophic failure of, 1145
- Reactions. *See* Chemical reactions
- Reactor block, in BFDs, 64
- Reactor feed preparation block, in BFDs, 63–64
- Reactors
 additional mass transfer effects, 965–969
 bare module factors for, 1274–1275
 batch optimization scheduling issues, 490–494
 control system for water-gas shift (WGS) reactor, 669–671
 cumene reactor case study, 683–685
 dynamic models for, 632
 energy balances and, 971–972
 equilibrium and, 964–965
 equipment cost data for, 1251
 heuristics for, 366
 input for process simulation, 407
 justifying conditions of special concern for, 150–154
 kinetics, 370–371
 kinetics and, 962–964
 mass balances and, 970–971
 models of, 972–980, 1001–1002
 optimization of, 477–478
 performance problems, 1003–1006
 purchase costs for, 1251, 1263
 reasons for multiple, 76
 recycling unwanted products from, 77
 selecting equipment parameters in PFD synthesis, 407
 synthesizing PFD from BFD, 372–373
 transforming feed chemicals into product chemicals, 137
 transport (pneumatic conveying) reactors, 1001
- Readability indices, word-processing software, 1216
- Reboilers. *See also* Boilers
 debottlenecking strategies for, 939
 impact on performance of distillation columns, 934–942
 in tray towers, 923–926
- Recommendations section
 oral presentation guidelines, 1213
 written report guidelines, 1205
 written report improvements, 1243–1244
- Recommended exposure limits (REL), NIOSH air contaminants, 1135
- Rectangular fins
 derivation of fin effectiveness for, 864–866
 fin efficiency for constant thickness, 829–831
 heat transfer surface examples, 833–837
 total heat transfer surface effectiveness, 831–832
- Recycle block, in BFDs, 65
- Recycle loops, defined, 142
- Recycle streams
 number of potential, 75–76
 in parametric optimization, 479
 in PFD synthesis, 389
 phase of, 77–78
 in process simulation, 413–415

- recognizing in chemical processes, 142–145
- in sequential modular approach, 576–577
- using tear streams to solve problems with, 400–401
- Recycle structure
 - effect of excess reactants on, 76
 - in batch processing, 97
 - efficiency of raw material usage, 70–71
 - formulating preliminary process flow diagram, 78–83
 - identification and definition of, 71–75
 - methods for unreacted raw materials, 76–77
 - number of reactors required, 76
 - overview of, 70
 - Pollution Prevention Act of 1990, 1160
 - purifying raw materials prior to recycling, 76
 - recycling unwanted product/inert, 76–77
- Reevaluate, PAR analysis for new heuristics, 349–351
- Reflux ratio
 - factors affecting, 897–899
 - reasons for designing high, 899–900
 - in single-variable optimization, 480–481
 - in two-variable optimization, 481–484
- Refractory-lined pipes, for high-temperature service, 703
- Refrigeration
 - estimating utility costs, 222, 225–228
 - heuristics for, 367
 - new chemical products needed for, 125, 127
 - ranges of cooling, 78
- Registered professional engineer, 1124–1125
- Registration, Evaluation, Authorization and Restriction of Chemicals (REACH), 1137
- Regulation
 - of chemical processes. *See* Control and regulation of chemical processes
 - health, safety and environment, 1134
 - legal liability of chemical engineers, 1125–1126
 - Pollution Prevention Act of 1990, 1159–1160
 - protection for whistle-blowers, 1115
- Regulations and agencies, HSE
 - EPA, 1140–1142
 - Internet addresses for federal agencies, 1134
 - list of acronyms for, 1154–1156
 - nongovernmental organizations, 1143–1144
 - OSHA and NIOSH, 1135–1140
 - overview of, 1134–1135
 - Process Safety Management (PSM), 1138–1140
- Regulatory control design, dynamic simulation in, 619
- Rehearsal of skills
 - in ethical decision-making, 1105–1106
 - nonprofessional responsibilities and, 1109–1110
 - and reflection in action, 1106–1107
- REL (Recommended exposure limits), NIOSH air contaminants, 1135
- Relationships in separations
 - energy balances, 877
 - equilibrium relationships, 877–878
 - mass balances, 876–877
 - mass transfer relationships, 878–881
 - overview of, 876
 - rate expressions, 882–883
- Release of waste, generated in processes, 1160
- Relief (or safety) valves, in pressure-relief systems, 1145, 1166
- Report-writing case study
 - assignment memorandum, 1221–1222
 - checklist of common mistakes for visual aids, 1244–1245
 - checklist of common mistakes for written text, 1245–1246
 - example of improved report, 1233–1244
 - example with suggestions for improvement, 1231–1233
 - overview of, 1221
 - response memorandum, 1222–1224
 - visual aids, 1224–1230
- Residual cost, evaluating profitability of equipment, 300–301
- Residue curves, ternary azeotropic distillation, 382–388
- Resistances, in heat transfer coefficients, 798–800
- Resource Conservation and Recovery Act (RCRA), 1141, 1161
- Resources
 - for engineering ethics, 1118–1121
 - on teamwork, 1190–1191
- Response memorandum, report-writing case study, 1222–1224
- Response surface techniques, parametric optimization, 487, 489
- Responsibilities, group member, 1183
- Responsible Care program, chemical industries, 1143
- Retentate, gas permeation for purifying, 950
- Retroactive liability, 1163, 1168
- Retrofitting, 305–309, 1091
- Return on investment, 298–299
- Revenue
 - cash flows/profits in terms of, 275
 - profit margin analysis and, 325–326
 - sensitivity analysis for quantifying risk, 316–318
- Rigorous hydrodynamic models, 1001
- Rigorous module, distillation column design, 409–411
- Risk
 - acceptance, 1133–1134
 - assessment, in health and safety, 1131–1134
 - concept of, 298–299
 - evaluating profitability, 309–310
 - forecasting uncertainty, 310–314
 - Monte-Carlo analysis for quantifying, 321–324
 - probabilistic approach to quantifying, 318–321
 - relationship to rate of return, 298–299
 - scenario analysis for quantifying, 314–315
 - sensitivity analysis for quantifying, 315–318
- Risk Management Plan (RMP), EPA, 1141–1142
- Rod baffles, S-T heat exchanger design, 785, 787
- Roles, group member, 1183
- Rotameters, measuring flowrate, 731
- Runaway reactions, 1145
- Runge-Kutta family methods, 636
- Rupture disks, in pressure relief systems, 1145
- S**
- S (Salvage value), nondiscounted profitability criteria, 288–291
- Safety. *See also* Health, safety, and environment (HSE)
 - considerations on when to purify the feed, 66–67
 - decision to use continuous vs. batch processes, 59
 - simulation in training for, 48
 - of work environment, 1131–1134
- Safety data sheets (SDS), HazCom, 1136–1138
- Safety (or relief) valves, in pressure-relief systems, 1145, 1166
- Sales volume, in profitability analysis, 310
- Salvage value (S), depreciation and, 288–289
- SARA (Superfund Amendments and Reauthorization Act)
 - CERCLA amended by, 1161
 - overview of, 1141
- Saturation
 - in condensing heat transfer, 824
 - heat transfer coefficients for pool boiling curve, 813–815
- Savings, banks and, 248–251
- Scale models, 3-D plant models, 33
- Scatter plots
 - as graphs in design reports, 1200
 - guidelines for reports, 1206–1207
- Scenario analysis, for quantifying risk, 314–315
- Scheduling
 - batch processes, 97–98, 490–494
 - flowshop plants, 103–106
 - group tasks, 1185–1186
 - jobshop plants, 101–103
- Scheduling charts, design reports, 1200
- Scientists, interactions among, 370
- Scope (Preliminary Design), in cost estimate, 172
- Screens
 - bare module factors for, 1275
 - equipment cost data for, 1251
 - purchase costs for, 1263
- Screw threads, pipe connections, 705
- Scrubbers, in pressure-relief systems, 1145
- SDS (safety data sheets), HazCom, 1136–1138
- Seals, on compressors, 708
- Secure disposal, Pollution Prevention Act of 1990, 1160
- Selectivity
 - in chemical product design, 124–125, 128–130
 - justifying reactors operating at temperature conditions of special concern, 153
 - for parallel and series reactions, 977–980
- Selexol unit design. *See* CO₂ and H₂S removal from coal-derived syngas
- Self-assessment, group effectiveness, 1178–1180
- Self-confidence, in oral communications, 1209–1210
- Semibatch processes, logic control in, 680–682

- Semicolons, written report guidelines, 1203
- Sensitivity analysis
 decision variables and, 471–472, 487
 in optimization, 489–490
 quantifying risk, 315–318
 steady-state simulators used in, 589
- Sensitivity coefficient, quantifying risk, 315–318
- Separate and purify, recycling unreacted raw materials, 71–73
- Separation
 in allyl chloride production, 1386, 1396–1397
 distillation in. *See* Distillation
 electrolyte applications, 428
 formulating PFD for, 83
 guidelines for choosing separation units, 374–376
 McCabe-Thiele method for, 903–905
 mist eliminators in V-L separation, 1040–1044
 optimization of, 476–479
 pollution prevention and, 1165
 using alternative technologies for, 477–478
 using mass separating agents, 876, 877
- Separation basis, defined, 875–876
- Separation equipment. *See also* Separators
 condensers and reboilers, 923–926
 distillation column performance, case study, 934–942
 drums, 911–912
 for extraction, 942–946
 for gas permeation membrane separations, 947–950
 overview of, 875–876
 packed towers, 927–933
 performance of packed and tray towers, 933–934
 for phase separation. *See* Knockout drums (phase separators)
 pressure drop and, 922–923
 tray towers. *See* Tray towers
- Separations, basic relationships in
 energy balances, 877
 equilibrium relationships, 877–878
 mass balances, 876–877
 mass transfer relationships, 878–881
 rate expressions, 882–883
- Separations, illustrative diagrams for
 Kremser and Colburn methods for dilute solutions, 905–911
 McCabe-Thiele diagram for distillation, 888–901
 McCabe-Thiele diagram for mass separating agents, 903–905
 McCabe-Thiele diagram for packed columns, 901–902
 TP-xy diagrams, 883–888
- Separator block, in BFDs, 64–65
- Separator feed preparation block, in BFDs, 64
- Separators. *See also* Distillation
 analyzing conditions of special concern for, 158–159, 164
 decision variables in parametric optimization, 479
 dynamic simulation of flash separators, 630–632
 justifying conditions of special concern for, 150–154
 optimization in batch systems and, 490–494
 phase. *See* Knockout drums (phase separators)
- Separators, synthesizing PFD from BFD
 azeotropic distillation, 378–379
 azeotropic distillation in binary systems, 379–382
 azeotropic distillation in ternary systems, 382–388
 feed preparation, 388–389
 gathering physical property data, 371
 guidelines for choosing separation operations, 374–376
 overview of, 374
- Sequencing, batch process design and, 91
- Sequential Function Chart (SFC), 680
- Sequential modular (SM) approach, to steady-state simulation
 accelerated successive substitution (relaxation) methods, 578
 Broyden's method, 579–580
 direct substitution algorithm, 578
 dominant eigenvalue method (DEM), 578–579
 equation-oriented (EO) approach vs., 585–586
 examples, 580–585, 587–589
 Newton's method, 579
 optimization of flowsheet convergence and, 590–591
 overview of, 572–578
 SMod approach as hybrid of SM and EO, 586–589
 solving optimization problem using, 592–595
 Wegstein's method, 579
- Series reactions, reaction kinetics, 977–980
- Servo control design
 dynamic simulation in, 619
 split-range control system, 671–672
- Set point (SP)
 feedback control system and, 663–665
 process control in dynamic simulation, 640, 644
- SF (stream factors), in calculation of yearly costs, 237–238
- Shell-and-tube (S-T) heat exchangers. *See also* Heat exchangers
 baffles, 784–787
 concentration/temperature profiles in reactors, 987–989
 design algorithm, 838–840
 design algorithm examples, 840–846
 design for pressure drop, 837–838
 effectiveness factor (F) and number of, 529–534
 estimating EAOC for network, 534–536
 estimating heat-exchanger network costs, 537–539
 fixed tubesheet and floating tubesheet (head), 783–784
 heat transfer coefficient for, 992–993
 heat transfer design in, 990–991
 heuristics, 788–789
 LMTD. *See* LMTD correction factors
- LMTD effectiveness charts, 861–864
 matching volume and heat transfer area, 997–999
 notations for, 781
 overview of, 779
 shell-and-tube partitions, 784–785
 shell configurations, 779–780
 shell-side flow patterns, 785–788
 standard designs for, 781–782
 tubesheet and tube configurations, 780, 782–784
- Shell type, heuristics for S-T heat exchangers, 788–789
- Shells, pressure vessel design for cylindrical, 1016–1021
- Shewart charts, in statistical process control, 682
- Shock wave, in explosions, 1144
- Short-term exposure limit (STEL), air contaminant hazards, 1135
- Shortcut methods, experience-based principles in process design, 348–349
- Shortcut module, in distillation column design, 409
- Sieve trays
 calculating flooding velocities, 915–916
 prone to weeping, 913
 for separation, 912
- Signatures, for design meeting minutes, 1199
- Simple distillation, PFD synthesis, 376–379
- Simple interest, 250, 252
- Simple phase separators. *See* Knockout drums (phase separators)
- Simple savings, 248
- Simplex-Nelder-Mead method, parametric optimization, 489
- Simulated annealing method, parametric optimization, 489
- Simulations
 augmented reality (AR), 46–47
 of chemical processes, 43–44
 common errors in using, 412–413
 convergence criteria and running, 411–412
 dynamic. *See* Dynamic simulators
 immersive training simulators (ITS), 45–46
 operator training simulators (OTS), 43–46
 output display options, 411
 training for emergencies, safety, and maintenance, 48
- Simulations, input data
 chemical components, 401
 equipment parameters, 405–411
 feed stream properties, 404–405
 flowsheet topology, 404
 physical property models, 401–404
- Simulators
 avoid using raw output in reports, 1217–1218
 dynamic. *See* Dynamic simulators
 expert systems in, 402
 and friction in groups, 1181
 function of, 397–398
 physical property databanks, 402
 progress reports, 1199
 steady-state. *See* Steady-state simulators
 structure of, 398–401

- synthesis of PFD using. *See* Synthesis of PFD, using simulators
 - types of, 397–398
 - Simultaneous method, solutions to DAE systems, 634–635
 - Simultaneous modular (SMod) algorithm
 - process simulator, 400
 - for process simulators, 400
 - SM algorithm vs. *See* Sequential modular (SM) approach, to steady-state simulation
 - steady-state simulation, 586–589
 - Single-input-single-output (SISO) controllers, dynamic simulation, 640
 - Single-pass conversion
 - number of potential recycle streams and, 75–76
 - overall conversion vs., 70–71
 - in parametric optimization, 479
 - reactor design and, 373, 970–971
 - shifting equilibrium of reaction, 68
 - thermodynamic equilibrium and, 964
 - Single-product campaigns, product storage for, 106–108
 - Single-stage steam ejectors, 1051–1054
 - Single-variable example, of parametric optimization, 480–481
 - SISO (single-input-single-output) controllers, dynamic simulation, 640
 - Site plans, 32
 - Six-tenths rule
 - capital cost for chemical plant, 182–183
 - capital cost for process equipment, 176–178
 - Size
 - base-case ratio and equipment, 737
 - dimensions of standard pipes, 703–705
 - of droplet distribution in L-L separation, 1044–1045
 - of pressure vessels, 1023–1024
 - of vessel in dynamic simulation, 622–624
 - Skills
 - assessment of, 1–6
 - developing with multiple experiences/feedback, 6
 - ethical decisions and, 1105–1106
 - SL. *See* Straight-Line (SL) depreciation method
 - SLE (solid-liquid equilibrium), 441–443
 - Slide shows, oral presentation guidelines, 1211–1213
 - SM. *See* Sequential modular (SM) approach, to steady-state simulation
 - Societal impact, of chemical engineering, 1101–1102
 - SOCMA (Synthetic Organic Chemicals Manufacturers Association), 1143
 - Software
 - author responsibility to know report, 1215–1218
 - PDMS, from Cadcentre, Inc., 41
 - virtual plant walkthrough, 34
 - Soilsorption coefficient, estimating fate of chemicals in environment, 1163
 - Solid-gas (adsorption), 903
 - Solid-liquid equilibrium (SLE), 441–443
 - Solid-liquid (leaching, washing, adsorption), 903
 - Solid-vapor equilibrium (SVE), 441–442
 - Solids modeling
 - overview of, 440
 - parameter requirements, 442–444
 - physical properties, 440–442
 - Solvents
 - chemical product design for new, 124
 - improving environment with green, 1164
 - minimizing pollution by recycling, 1165
 - Sour-water stripper (SWS), developing, 435–440
 - Source reduction regulation, Pollution Prevention Act, 1159–1160
 - SOYD (sum of the years digits) depreciation method, 270–273
 - SP (set point)
 - feedback control system and, 663–665
 - process control in dynamic simulation, 640, 644
 - SPC (statistical process control), 682
 - Special process hazards factor, Dow Fire & Explosion Index, 1152
 - Speciality chemicals, 123, 124
 - Spelling
 - using spell-checkers for written reports, 1215
 - in written design reports, 1202–1203
 - Split-range control system, 671–673
 - Splitters
 - identifying recycle and bypass streams, 144–145
 - input for process simulation, 407
 - tracing chemical pathways in PFDs, 135–136
 - SQP (Successive Quadratic Programming), in flowsheet optimization, 590–592
 - Square pitch
 - Kern's method for shell-side heat transfer, 810–813
 - layout patterns for tubes, 784
 - mechanical cleaning on shell side with, 783
 - ST (Structured Text), logic control, 680
 - Stack, in pressure-relief system, 1145
 - Stage cut, in gas permeation, 949
 - Staged separation, in dilution, 906–907
 - Staging, of compressors, 750–752
 - Stainless steel
 - advantages/disadvantages of, 356
 - estimating plant cost for MOCs, 194–197
 - for pipes in extreme conditions, 703
 - temperature conditions of special concern for reactors/separators, 151
 - Standards for Steam Jet Vacuum Systems*, 1050
 - Start-up procedures, developing with P&IDs, 31
 - State variables, 617, 619
 - Stationary head, fixed and floating tubesheet design, 783–784
 - Statistical process control (SPC), 682
 - Steady-state design, with OTS, 688
 - Steady-state material balance, maintaining process control, 656
 - Steady-state simulators
 - accelerated successive substitution (or relaxation) methods, 578
 - Broyden's method, 579–580
 - direct substitution method, 578
 - dominant eigenvalue method (DEM), 578–579
 - dynamic simulation using topological changes from, 619–622
 - dynamic simulators compared to, 618
 - equation-oriented (EO) approach, 585–586
 - estimating physical property parameters, 601–604
 - need for, 562
 - Newton's method, 579
 - operator training simulators (OTS) as, 43–45
 - optimization studies, 589–592
 - optimizing cost function in flowsheet, 593–595
 - optimizing cost of syngas production, 595–600
 - overall heat transfer coefficient, 798–800
 - overview of, 562
 - sensitivity studies using, 589
 - SM approach to, 572–578, 580–585
 - SMod approach to, 586–589
 - solution strategy for, 571–572
 - user-added models (UAM) and, 562–563
 - user-added unit operation models (UAUOM), 563–564
 - user kinetic models, 568, 571
 - user thermodynamic and transport models, 564–565
 - Wegstein's method, 579
- Steam
 - condensation, 676–678
 - conditions of special concern for, 155
 - conventions for identifying in PFDs, 18
 - cost for high-pressure, 230–231
 - cost for low-pressure, 233–234
 - cost for medium-pressure, 231–233
 - cost of manufacturing (COM), 214, 241–242
 - cost of production, 228–234
 - cumene production facility problems, 1418
 - elevating condensers for high-pressure, 41
 - heuristics for physical properties and, 355
 - heuristics for piping and, 360
 - heuristics for refrigeration and, 367
 - heuristics for steam turbines, 358
 - input/output structure of process flowsheet for, 66–68
 - low-temperature heating via low-pressure, 389
 - recycling unwanted product and controlling, 77
 - regulation scheme for cumene reactor, 684–685
 - supply options for, 221
 - temperature conditions of special concern for, 152
 - troubleshooting cumene reactor, 1078–1081
 - utility costs for off-site, 222–223
 - in utility streams of PFDs, 62
 - Steam ejectors
 - air leaks into vacuum systems, and load for, 1050–1051
 - multistage, 1054–1057
 - performance of, 1057–1058
 - purpose of, 1015, 1049–1050
 - running columns at vacuum with, 925
 - single-stage, 1051–1054

- Stefan-Maxwell equation
 modeling electrolyte systems, 434
 thermodynamics, 564–565
- STEL (short-term exposure limit), air
 contaminant hazards, 1135
- Stiff problems, 635, 636
- Stoichiometric reactors, equipment parameters
 in PFD synthesis, 407
- Stoichiometry, in process concept diagrams,
 60–61
- Stokes law
 flow around submerged objects, 724
 in L-L separation, 1044–1045
- Storage
 intermediate, 108–110
 minimizing pollution during loading/
 unloading tanks, 1165–1166
 for single-product campaigns, 106–108
- Storage vessels, heuristics for, 359
- Storming stage, in group evolution, 1184–1185
- Straight fin thickness examples, 829
- Straight-Line (SL) depreciation method
 defined, 270
 example, 271–273
 MACRS depreciation allowances
 using, 273–274
 taxation, cash flow, and profit using, 276
- Strategies for Creative Problem Solving* (Fogler and
 LeBlanc), 1191
- Strategies, for written communications,
 1201–1202
- Stream factors (SF), in calculation of yearly
 costs, 237–238
- Streams
 base-case ratios applied to properties of, 737
 bypass streams, 142–145
 for cocurrent heat exchanger, 773–775
 combining data to give PFD, 21–24
 in countercurrent heat exchangers, 771–773
 design reports, 1197–1198
 exchanging heat between, 674–679
 feed streams. *See* Feed chemicals/feed streams
 increasing pressure/regulating flowrate in,
 674–676
 information in PFDs, 18–20
 input/output structure and, 60–61
 with phase changes, 775–776
 with phase changes for HEN
 costs, 539–540
 phase to be recycled, 77
 recycle streams. *See* Recycle streams
 recycling feed and product with/without
 purge stream, 73–75
 regulating processes by manipulation of, 655
 tactics for tracing chemicals, 135–136
 tear streams. *See* Tear streams
 utility streams. *See* Utility streams
 waste streams. *See* Waste streams
- Stress and strain relationships
 cylindrical shell design for pressure vessel,
 1016–1021
 in pressure vessel design, 1016
- Stress intensity factor, pressure vessel design, 1022
- Strippers
 debottlenecking strategy for, 939–941
 developing sour-water stripper (SWS),
 435–440
 in mass-exchange networks, 541–542
 mass separating agents for, 903–904
 obtaining height of packed column, 929
 simulating, 411
 in SM approach, 572
- Stripping section, of distillation column, 890
- Structural support diagrams, 32
- Structure-mounted vertical arrangement, plant
 layout, 36
- Structured packings, 928
- Structured Text (ST), logic control, 680
- Student self-assessment, 2–4
- Studies, steady-state simulation, 589
- Study groups, team, 1189–1190
- Study (Major Equipment or Factored), capital
 cost estimate of chemical plant, 172–174
- Styrene, equilibrium control in, 67–68
- Styrene production
 major equipment summary, 1297–1298
 making it greener, 1171
 overview of, 1291
 process description, 1291–1292
 process flow diagram, 1293
 reaction kinetics, 1292, 1299
 references, 1299
 simulation (CHEMCAD) hints, 1299
 stream tables, 1294–1296
 utility summary table, 1296
- Submerged objects, frictional flow of fluid for,
 723–728
- Substitution of hazardous materials, inherently
 safe design, 1153
- Successive Quadratic Programming (SQP)
 case study. *See* Report-writing case study
 in flowsheet optimization, 590–592
- Successive Quadratic Programming (SQP), in
 flowsheet optimization, 590–592
- Sulfur. *See* Claus unit design, converting H₂S to
 elemental sulfur
- Sum of the years digits (SOYD) depreciation
 method, 270–273
- Summation equations, MESH, 435–440
- Superfund Amendments and Reauthorization
 Act (SARA)
 CERCLA amended by, 1161
 overview of, 1141
- Supply and demand, in chemical markets,
 311–314
- Surface tension
 heuristics for liquid-liquid extraction, 365
 modeling aqueous electrolyte
 system, 438–439
 modeling distillation column for electrolyte
 systems, 449
 modeling electrolyte systems, 434–435
 in Onsager-Samaras Law, 434–435
- Surge line, for centrifugal compressor, 749–750
- Surge tanks, 687
- Survival of personnel, inherently safe design, 1154
- SVE (solid-vapor equilibrium), 441–442
- Swing check valves, 706
- Symbols
 for equations in reports, 1207–1208
 identifying on P&IDs, 29–30
 for use in PFDs, 16–20
- Symptoms
 process for troubleshooting, 1065–1066,
 1069–1070
 troubleshooting multiple units, 1076–1078
- Synergy, group efficiency and, 1176–1178
- Syngas, optimization study, 595–600
- Synthesis of PFD, from BFD
 azeotropic distillation, 378–379
 azeotropic distillation in binary systems,
 379–382
 azeotropic distillation in ternary systems,
 382–388
 environmental control section, 389
 equipment summary table, 390–391
 flow summary table, 390
 guidelines for choosing separation
 operations, 374–376
 information needs and sources, 370–371
 overview of, 369
 process control loops, 390
 reactor and separator feed preparation, 388–389
 reactor section, 372–373
 recycle section, 389
 separator section, 373–376
 simple distillation, 376–378
- Synthesis of PFD, using simulators
 applying thermodynamic models, 424–426
 building model of aqueous electrolyte, 435–440
 calculating Gibbs free energy for electrolyte
 system, 445–447
 chemical components, 401
 chemical equilibrium in modeling electrolyte
 systems, 432
 choosing thermodynamic models, 415–424
 common errors, 412–413
 convergence criteria for simulation, 411–412
 diffusion coefficient in modeling electrolyte
 systems, 433–434
 electrolyte systems modeling, 428–435
 enthalpy model, 416–423
 equipment parameters, 405–411
 feed stream properties, 404–405
 flowsheet topology, 404
 handling recycle streams, 413–415
 heat capacity in modeling electrolyte
 systems, 431–432
 information needed (input data), 401
 modeling distillation column for electrolyte
 system, 447–519
 molar volume in modeling electrolyte
 systems, 432
 output display options, 411
 overview of, 397–398
 parameters for solids model, 442–444
 phase equilibria, 416–417
 physical properties in solids modeling,
 440–441
 physical properties in thermodynamics, 416
 physical property models, 401–404
 solids modeling, 440–444
 structure of process simulator, 398–401
 surface tension in modeling electrolyte
 systems, 434–435

- thermal conductivity in modeling electrolyte systems, 433
- toluene HDA case study, 426–428
- viscosity in modeling electrolyte systems, 432–433
- Synthesis pathways, in green chemistry, 1164
- Synthetic Organic Chemicals Manufacturers Association (SOCMA), 1143
- System curves, analyzing pump and, 743–749
- T**
- T-Q diagrams. *See* Temperature-enthalpy (T-Q) diagrams
- Table of contents, written report guidelines, 1204
- Tables
 - common mistakes in presenting, 1227–1228
 - in design reports, 1200
 - learning software used for, 1217
 - written report guidelines, 1206–1207
- TAMU (Texas A&M University), engineering ethics at, 1118
- Tanks. *See also* Vessels
 - equipment cost data for, 1251
 - pressure factors for, 1266
 - purchase costs for, 1258
- Task differentiation, in groups, 1176–1177
- Taxation
 - impact of tax rate on profit, 274–277
 - MACRS as current method of tax depreciation, 273–274
 - types of depreciation, 269–273
- Teamwork. *See also* Groups
 - assessing group effectiveness, 1178–1180
 - essential to chemical engineering, 1175
 - group evolution, 1184–1186
 - groups and, 1175–1176
 - learning in teams, 1189–1190
 - misconceptions about, 1189
 - organizational behaviors and strategies, 1180–1184
 - resources on, 1190–1191
 - task differentiation in, 1176–1177
 - team building, 1186–1187
 - unique characteristics of teams, 1187–1188
- Teamwork and Project Management* (Smith), 1191
- Teamwork from Start to Finish* (Rees), 1190
- Tear streams
 - convergence methods, 580–585, 587–589
 - convergence methods, comparing performance of, 583
 - in sequential modular (SM) approach, 572, 575–578
 - solving problems with recycles, 400–401
- Technology, new
 - advancing steady-state simulation with, 562
 - evaluating risks of, 324–325
- Tees, changing flow direction, 705
- Temperature. *See also* Heat-exchanger networks (HENs)
 - composite temperature-enthalpy diagram, 523–529
 - in condensing heat transfer, 824–828
 - designing nonisothermal CSTRs, 980–984
 - effect of ambient conditions on dynamic models, 624
 - evaluating reactor process conditions, 158–164
 - impact on reaction rate, 162–163, 980
 - impacting bare module equipment costs, 190–192
 - justifying conditions of special concern in reactors/separators in PFD, 158–164
 - measuring process variables, 662
 - in MUMNE problem, 512–521
 - operating conditions of special concern for reactors/separators, 150–154
 - physical property variations with, 355
 - pinch temperature, 514–515
 - reactor design for PFD synthesis and, 372–373
 - reasons for multiple reactors, 76
 - regulating between process streams and utilities, 676–679
 - troubleshooting cumene reactor, 684–685
 - troubleshooting packed-bed absorber, 1071–1074
- Temperature-enthalpy (T-Q) diagrams
 - analyzing reboiler performance after scale-down, 936–937
 - for condensers and reboilers, 923–924
 - for heat exchangers, 772–774, 776–778, 794
 - for phase changes, 775–776, 797–798
- Tempered-water system, split-range control system, 671–672
- Tensile strength, impact of temperature on, 151
- Terminal velocity
 - of falling water drops in oils with different viscosity, 1045–1046
 - flow around submerged objects, 723–728
 - for water drops in air and oil, 1044–1045
- Terminology
 - dynamic simulation, 617
 - fires and explosions, 1143
 - optimization, 464
- Ternary azeotropic distillation, 382–388
- Texas A&M University (TAMU), engineering ethics at, 1118
- The Team Handbook* (Scholtes et al.), 1191
- Thermal conductivity
 - copper and its alloys used for high, 194
 - of metals and tubes in heat exchangers, 800–801
 - modeling aqueous electrolyte system, 438
 - modeling electrolyte systems, 433
 - physical property heuristics for, 355
 - solids modeling and, 442
 - using physical property data
 - for PFD design, 371
- Thermal insulation, heuristics for, 362
- Thermal systems, cost of off-site, 223
- Thermodynamic model solver, simulator features, 399
- Thermodynamic models
 - calibrating using scarce data, 422–423
 - enthalpy model, 416
 - estimating physical property parameters, 601–604
 - example of using, 424–426
 - hybrid systems, 423
 - modeling distillation column for electrolyte system, 447–448
 - other models, 423
 - phase equilibrium model, 416–422
 - pure-component properties, 416
 - selecting, 415–416
 - user, 564–567
 - using, 424
 - validity of pressure-flow networks in dynamic simulation, 621–622
- Thermodynamics
 - equilibrium in reactors and, 964–965
 - justifying conditions of special concern in reactors using PFD, 158–161
 - must have confidence in selected model for, 404
- Thermosiphon reboilers, 40–41, 633, 779
- Thesaurus, 1215
- Threshold limit values (TLV), air contaminants standard, 1135
- Tie line, TP-xy diagrams for V-L separations, 887
- Time criteria
 - discounted profitability criteria, 291–293
 - evaluating profitability, 287
 - nondiscounted profitability, 287
- Time value of money, investments and, 248–251, 259–261
- Time-weighted average (TWA), air contaminant exposure, 1135
- Tips for Teams* (Fisher et al.), 1191
- Titanium and its alloys, selecting materials of construction, 194–197
- Title page, written report format, 1203
- Title slide, oral presentation guidelines, 1212
- TLV (threshold limit values), air contaminants standard, 1135
- Toluene HDA process
 - analyzing conditions of special concern in, 158–164
 - BFD for, 11
 - case study of simulating, 426–428
 - cost of manufacturing benzene via, 241–242
 - determining profit margin, 68–69
 - distillation column performance, case study, 934–942
 - distillation of benzene from, 14–15
 - equipment summary for, 24–25
 - estimating utility costs from PFDs, 238–240
 - evaluating high-pressure phase separator in, 164
 - feed purity and trace components in, 66
 - input/output structure, 60–63
 - PFD for, 22
 - process flow diagram, 17, 20
 - recycle and bypass streams, 142–145
 - specifying equipment parameters for, 409–411
 - tracing primary chemical pathways, 137–142
 - written process description of, 146–147
- Top-down strategies, in optimization, 468
- Topological optimization
 - alternatives for separation and reactor configuration, 477–478
 - eliminating equipment, 475
 - eliminating unwanted by-products/waste streams, 473–475
 - introduction to, 473
 - rearranging equipment, 475–477

- Topology. *See* Process topology
- Torispherical (dished) heads, pressure vessels, 1022–1024
- Torts, and chemical engineers, 1126
- Total capital for depreciation, 269
- Total module costs, vs. grassroots, 201–203
- Total reflux, 897
- Towers
- capacities of process units in common usage, 356
 - equipment cost data for, 1251
 - heuristics for, 363
 - pressure factors in costs of, 1266
- Toxic Release Inventory, 1141
- Toxic Substances Control Act (TSCA), 1161
- TP-xy diagrams, 876–888
- Trace contaminants, minimizing pollution, 1165
- Tracing chemical pathways, in PFDs
- guidelines and tactics, 135–136
 - limitations of, 145–146
 - recycle and bypass streams, 142–145
 - tracing nonreacting chemicals, 145
 - tracing primary paths taken by chemicals, 136–142
 - written process description, 146–147
- Tracing chemical species, tactics for, 997
- Training
- for emergencies, safety and maintenance, 48
 - immersive training simulators (ITS), 45
 - linking OTS with ITS, 46–47
 - operator training simulators (OTS), 43–45
 - using P&IDs in operator, 31
- Transfer units separation, 880–881, 929
- Transient response, using dynamic simulation to study, 618
- Transmittal letters, for written communications, 1198
- Transport models
- building model of distillation column for electrolyte system, 448–449
 - user, 564–567
- Transport (pneumatic conveying)
- reactors, 1001
- Trapezoidal method, dynamic simulation
- integrator algorithms, 636
- Tray towers
- choosing packed tower vs., 933
 - column diameter, 914–919
 - column height, 914–915
 - condensers and reboilers, 923–926
 - downcomers, 912
 - energy balances, 877
 - entrainment, 914
 - equilibrium relationships, 877–878
 - flooding, 914–920
 - flow patterns, 912–914
 - heuristics for distillation/gas absorption, 364
 - Kremser and Colburn methods for dilute solutions, 905–911
 - mass transfer relationships, 878–881
 - McCabe-Thiele method for distillation, 888–901
 - McCabe-Thiele method for mass separating agents, 903–905
 - McCabe-Thiele method for packed columns, 901–902
 - performance of, 933–934
 - performance problems of, 933–934
 - pressure drop, 922–923
 - rate expressions, 882–883
 - tray efficiency, 920–922
 - tray sizing, 915–916
 - tray spacing, 914–919
 - tray types, 912–913
 - vs. packed towers, 933
 - weirs, 912–914
- Trays
- bare module cost for, 1270
 - bare module factors for, 1271
 - efficiency in distillation column, 920–922
 - equipment cost data for, 1251
 - material factors for, 1273
 - McCabe-Thiele method for distillation using, 903–905
 - pressure factors for, 1266
 - purchase costs for, 1257
- Triangular fins, 831–832, 833–837
- Triangular pitch
- heat transfer coefficients for flow over tubes, 808
 - Kern's method for shell-side heat transfer, 812–813
 - layout patterns for tubes, 784
- Troubleshooting. *See also* Debottlenecking:
- Performance
 - applying to problems, 1069–1071
 - case studies involving multiple units, 1076–1081
 - cumene process feed section, 1074–1076
 - for an entire process, 1081–1085
 - fluid flow. *See* Fluid flow equipment, performance
 - overview of, 1065–1067
 - packed-bed absorber, 1071–1074
 - performance. *See* Performance
 - problem-solving strategies, 1067–1069
 - simulation errors, 412–413
 - steps in, 1066
- TSCA (Toxic Substances Control Act), 1161
- Tuning parameters, process control in dynamic simulation, 641–643
- Turbines
- equipment cost data for, 1251
 - mechanical energy balance in piping systems, 700–703
 - pressure factors for, 1266
 - purchase costs for, 1254
 - utility costs for steam production, 228–234
- Turbulent flow
- falling-film condensation on cylinders, 825–828
 - film heat transfer coefficient inside tubes, 804–806
 - friction factors in compressible flow, 719–720
 - friction factors in incompressible flow, 712
 - frictional losses for, 709–711
- Turbulent fluidized bed reactors, 1000–1001
- TWA (time-weighted average), exposure to air contaminants, 1135
- Two-phase model, bubbling fluidized beds, 999–1000, 1002
- U**
- U-tubes, S-T heat exchanger design, 784, 789
- UAMs. *See* User-added models (UAMs)
- UEL (Upper explosive limit), 1144
- UFL (Upper flammability limit), 1144
- Uis (unlimited intermediate storage), in batch processing, 108
- Unexpected behavior, in problem-solving, 1068–1069
- UNIFAC model, 422
- Unlimited intermediate storage (uis), in batch processing, 108
- Unstable systems, dynamic modeling for, 619
- Unwanted products, recycling, 77
- Upper explosive limit (UEL), 1144
- Upper flammability limit (UFL), 1144
- U.S. Coast Guard, and transport of hazardous materials, 1141
- User-added models (UAMs)
- examples, 565–570
 - overview of, 562–563
 - user kinetic models, 568–571
 - user thermodynamic and transport models, 564–567
- User-added unit operation models (UAUOM), steady-state simulation, 563–564
- Utilities
- constructing P&IDs, 27–29
 - dynamic models for heaters and coolers, 625–627
 - heuristics for refrigeration and utility specifications, 367
 - sketching piping in 3-D plot plan, 41
- Utility costs
- background information on, 219–222
 - calculation of, 221–222
 - for cooling water tower, 221–225
 - estimating from PFDs, 238–240
 - formula for cost of manufacturing, 214–217
 - for hot circulating heat transfer fluids, 234
 - for optimization base case, 469
 - problems with multiple utilities, 539
 - for refrigeration, 225–228
 - in single-variable optimization, 480–481
 - for steam production, 228–234
 - in toluene HDA process, 241–242
 - in two-variable optimization, 483
- Utility flowsheets, 32
- Utility streams
- for cocurrent heat exchanger, 773–775
 - conventions for identifying in PFDs, 18–20
 - in countercurrent heat exchangers, 771–773
 - cumene production facility problems, 1422
 - exchanging heat between process streams and, 676–678

- exchanging heat/work between process streams and, 674–679
 - identifying on PFDs, 14–15, 62–63
 - manipulating to regulate processes, 655 with phase changes, 775–776
- V**
- V-L. *See* Vapor-liquid (V-L) separation
 - Vacuum pumps, heuristics for, 361
 - Vacuum systems
 - conditions of special concerns for reactors/separators, 150
 - estimating air leaks for steam ejectors, 1050–1051
 - in single-stage steam ejectors, 1051–1052
 - Valves
 - analyzing conditions of special concern for pressure control, 164
 - binary distillation column case studies, 685–688
 - conditions of special concern for, 155–158
 - controlling processes with, 656
 - as final control in chemical process control loop, 29
 - input for process simulation, 407
 - minimizing pollution from leaking, 1166
 - regulating, 657–659
 - regulating flowrate with, 655–656, 660–662, 674–676
 - regulating pressure with, 660–662, 674–676
 - relief or safety, 1145
 - split-range control system, 671–673
 - types of, 705–706
 - Vanes, of impeller for centrifugal pumps, 707
 - Vapor
 - in condensing heat transfer, 824–828
 - damaging pumps, 706
 - justifying separator operations at conditions of special concern, 153–154
 - Vapor cloud explosions (VCEs), 1144–1145
 - Vapor fraction, and feed streams, 404–405
 - Vapor-liquid equilibrium (VLE)
 - air leaks into vacuum systems and, 1050–1051
 - estimating physical property parameters, 601–604
 - hybrid systems and, 423
 - justifying separator operations at conditions of special concern, 153–154
 - liquid-state activity-coefficient models, 419–423
 - modeling electrolyte systems with, 429–431
 - thermodynamic model solver and, 399
 - Vapor-liquid (V-L) separation
 - designing horizontal V-L separators, 1032–1036
 - designing V-L separators, 1029–1032
 - equilibrium relationships and, 878
 - flooding in mist eliminators, 1038–1040
 - flooding in mist eliminators, examples, 1040–1044
 - mass balances and, 877
 - McCabe-Thiele method for distillation and, 888–901
 - mist eliminators/other internals in, 1036–1037
 - overview of, 1025–1028
 - in packed towers. *See* Packed towers
 - TP-xy diagrams for, 883–888
 - in tray towers. *See* Tray towers
 - Vapor pressure, impacting fate of chemicals in environment, 1162
 - Vaporization, 883–884
 - Vaporizers
 - bare module cost for, 1270
 - bare module factors for, 1271
 - equipment cost data for, 1251
 - material factors for, 1272–1273
 - pressure factors for, 1266
 - purchase costs for, 1253
 - Variables
 - in cascade regulation, 668–669
 - in combination feedback/feed-forward control, 667
 - control strategies for, 663
 - in dynamic simulation, 619
 - in feed-forward control and regulation, 663–665
 - in feedback control and regulation, 663–665
 - measuring, 662–663
 - VB (Visual Basic), 563
 - VCEs (vapor cloud explosions), 1144–1145
 - Velocity
 - calculating flooding, 915–920
 - flow around submerged objects and terminal, 723–728
 - for fluidized beds, 728–730
 - friction factors in incompressible flow, 712–719
 - Kern's method for shell-side heat transfer, 810
 - minimum fluidization, 728–730
 - Velocity head, calculating frictional losses, 710
 - Venturi, measuring flowrate with, 731, 735
 - Vessels
 - bare module and material factors for, 1267–1271
 - capacities of process units, 356
 - dynamic model of flash and, 632
 - dynamic simulation and size of, 622–624
 - equipment cost data for process, 1251
 - estimating plant cost for MOCs, 197–198
 - pressure. *See* Pressure vessels
 - pressure factors for process, 1264, 1266
 - purchase costs for, 1258
 - reaction. *See* Reaction vessels
 - sketches for successful project completion, 32
 - Videos, for oral presentations, 1211–1212
 - Virtual Plant Tour AVI file, for this book, 41–43
 - Virtual reality
 - 3-D immersive training simulators, 45
 - linking OTS with ITS, 46–47
 - training for emergencies, safety and maintenance using, 48
 - viewing plant before construction, 33
 - Viscosity
 - calculating frictional losses, 709
 - of continuous fluid in L-L separation, 1045–1046
 - heat transfer coefficients for turbulent flow in tubes, 804–806
 - modeling electrolyte systems, 432–433
 - S-T heat exchanger heuristics, 789
 - Visual aids
 - content of, 1213
 - oral presentation guidelines, 1211–1212
 - report-writing and, 1224–1230, 1244–1245
 - Visual Basic (VB), 563
 - VLE. *See* Vapor-liquid equilibrium (VLE)
 - Voice, in oral presentations, 1214
 - Volatile organic compounds (VOCs), Clean Air Act Amendments, 1140–1141
 - Volume of catalyst, and heat transfer in S-T reactors, 997–999
 - Volute, and centrifugal pumps, 707
- W**
- Waste disposal, utility costs for plant with multiple process units, 223
 - Waste heat boilers, 234, 823–824
 - Waste management, Pollution Prevention Act of 1990, 1159–1160
 - Waste streams
 - activated sludge in biological, 390
 - cost of treating liquid/solid, 240–241
 - eliminating unwanted hazardous by-products, 477–478
 - phthalic anhydride production design for new facility, 1412
 - separator design for PFD synthesis, 373–374, 376
 - Waste treatment, Pollution Prevention Act of 1990, 1160
 - Wastewater treatment
 - cost of utilities for plant, 223
 - in green engineering, 1165
 - information in utility streams for, 18
 - maximum concentrations of discharges in, 1126
 - modeling electrolyte systems for, 428
 - for pollution prevention in styrene production, 1167
 - in process optimization, 471, 476
 - recycling of inerts in, 76
 - utility costs for, 223
 - Water
 - environmental laws for, 1161
 - leaks in steam production requiring makeup, 228
 - minimize pollution by recycling, 1165
 - properties at different temperatures, 812
 - temperature conditions of special concern for, 151–152
 - utility costs for cooling tower, 214–217
 - utility costs for plant with multiple process units, 222
 - utility costs for steam production, 228–234
 - Water-gas shift (WGS) reactor
 - converting CO to CO₂, 1352–1356
 - ratio control, 669–671
 - Weeping, bubble cap/valve trays and, 913

- Wegstein's method
 - performance for tear stream convergence, 583
 - SM approach to steady-state simulation, 579–585
 - Weir height, estimating column pressure drop, 912, 922–923
 - Weirs, liquid level on tray maintained by, 912
 - Welded joints, cylindrical shell design for
 - pressure vessel, 1016
 - Welds, connecting pipe with, 705
 - What-if technique, in Process Hazard Analysis, 1146
 - Work, and friction in groups, 1180
 - Worker Right to Know regulations, 1136–1138
 - Working capital, depreciation of, 269
 - Worst case scenario, risk assessment, 1133–1134
 - Writer's block, causes of, 1201
 - Written communication
 - executive summaries and abstracts, 1198–1199
 - exhibits (figures and tables), 1200
 - minutes from design meetings, 1199
 - overview, 1195–1196
 - performance evaluations, 1199
 - purposes of, 1196–1197
 - references, 1200
 - software and author responsibility, 1215–1218
 - strategies for writing, 1201–1202
 - transmittal letters or memos, 1198
 - university guidelines for written design reports, 1202–1209
 - Written process descriptions, 146–147
 - WVU and Auburn University, oral
 - communication guidelines, 1212–1214
 - WVU and Auburn University, written report
 - guidelines
 - equations, 1207–1208
 - figures and tables, 1206–1207
 - format, 1203–1206
 - grammar, punctuation, and spelling, 1202–1203
 - group reports, 1203
 - how engineering reports are used, 1208–1209
 - overview of, 1202
 - written communication, 1202–1209
- Y**
- Yearly depreciation, 270
 - Yearly operating cost (YOC)
 - of equipment with different operating lives, 301, 303–304
 - estimating utility costs from PFDs, 239–240
 - stream factors in calculating, 237–238
 - Yearly savings, and pollution prevention, 1167–1168
 - Yield, of parallel and series reactions, 977–980
- Z**
- Zebra mussels
 - brainstorming ideas in chemical product design, 128
 - new chemical products needed to prevent, 126
 - product manufacturing, 130–131
 - Zero wait (zw) batch process, 108
 - Ziegler-Nichols tuning rule, dynamic simulation, 641–643
 - Žukauskas equation, heat transfer coefficients, 808–809

CREDITS

Page 706, Figure 19-3: Republished with permission of Elsevier, from *Chemical Process Equipment: Selection and Design*, Couper, James R., 3rd edition 2012; permission conveyed through Copyright Clearance Center, Inc.

Page 707, Figure 19-4b: Republished with permission of Elsevier, from *Chemical Process Equipment: Selection and Design*, Couper, James R., 3rd edition 2012; permission conveyed through Copyright Clearance Center, Inc.

Page 708, Figure 19-5a, b: Republished with permission of Elsevier, from *Chemical Process Equipment: Selection and Design*, Couper, James R., 3rd edition 2012; permission conveyed through Copyright Clearance Center, Inc.

Page 889, Figure 21-10b: Republished with permission of Elsevier, from *Chemical Process Equipment: Selection and Design*, Couper, James R., 3rd edition 2012; permission conveyed through Copyright Clearance Center, Inc.

Page 912, Figure 21-32: Republished with permission of Elsevier, from *Chemical Process Equipment: Selection and Design*, Couper, James R., 3rd edition 2012; permission conveyed through Copyright Clearance Center, Inc.

Page 921, Figure 21-36: Republished with permission of Elsevier, from *Chemical Process Equipment: Selection and Design*, Couper, James R., 3rd edition 2012; permission conveyed through Copyright Clearance Center, Inc.

Page 927, Figure 21-39: Republished with permission of Wiley, from *Distillation: Principles and Practice*, Stichlmair, J. G., and J. R. Fair, 1998; permission conveyed through Copyright Clearance Center, Inc.